

# COMPLETE MONOLITHIC ANALOG MULTIFUNCTION CHIP

## AD538 Embodies $Y(Z/X)^M$ with High Performance and Wide Dynamic Range Performs Multiplication, Division; Computes Powers, Roots, Logs, Antilogs

by Lew Counts, Charles Kitchin, and Steve Sherman

The AD538\* is a Real-Time Analog Computational Unit (ACU) in an 18-pin DIP. It performs the function,

$$\text{OUTPUT} = Y \left[ \frac{Z}{X} \right]^M \quad (1)$$

where the OUTPUT is a positive voltage and the variables, X, Y, and Z, represent inputs in the form of positive voltage or current. The AD538 can be used for multiplication and division (simultaneously), powers and roots, logarithms and antilogarithms. Its repertoire of analog computing operations makes the device useful in ratio measurements, signal conditioning, linearization, measurement of energy and stochastic quantities, and control.

The AD538's versatility is the serendipitous result of a quest for a monolithic analog division circuit that could accurately compute ratios over a wide dynamic range of denominator values; indeed, this is its most important application. With a 1000:1 dynamic range ( $V_z = V_x = 10 \text{ mV}$ ,  $V_y = 10 \text{ V}$ ,  $V_o = 10 \text{ V}$ ), the maximum total error (AD538B) is only 2.5% of output — with no external trims.

Conventional IC analog multipliers, configured and optimized for division, have yet to achieve even the modest 100:1 dynamic range specification that might be considered practical for many divider applications; for example, the premium AD535K\* (*Analog Dialogue* 12-2, 1978) is specified to have maximum total error of 2% over a 50:1 dynamic range of denominator input, with no external trims.

Besides overcoming the dynamic-range limitations of dividers based on multipliers, the AD538 has low input offsets ( $100 \mu\text{V}$  or less) and low noise, essentially proportional to output for outputs above 10 mV; for 1-volt output in a 1-kHz bandwidth, peak-to-peak output noise is about 1.4 mV. In addition to performing one-quadrant multiplication, it can also be configured for division in two quadrants, i.e., a bipolar numerator by a unipolar denominator; and it can calculate a wide range of powers or roots, whether positive (direct) or negative (inverse), integer or fractional (for example, 2.25,  $\frac{1}{2}$ ,  $-2$ ). With feedback, it can be configured to perform rms and vector operations.

Though generally similar in function—and many of its applications—to the Model 433\* module (see *Analog Dialogue* 6-2 (1972) and Chapter 3-6 of the *Nonlinear Circuits Handbook*<sup>1</sup>), the AD538 is considerably more versatile and much lower in cost. Figure 1 is a combined block diagram and pinout of the AD538; it comprises five precision op amps—laser-trimmed to less than  $100 \mu\text{V}$  of offset voltage, an accurate reference source (configurable for +10V or +2V), and an error-corrected computing core. Functionally, the device is disposed into a *log-ratio* section, an *antilog* section, and a *voltage reference*. High performance, with the high-yield bipolar process employed, is the result of advanced circuit design and a thermally balanced chip layout.

<sup>1</sup>See REFERENCES.

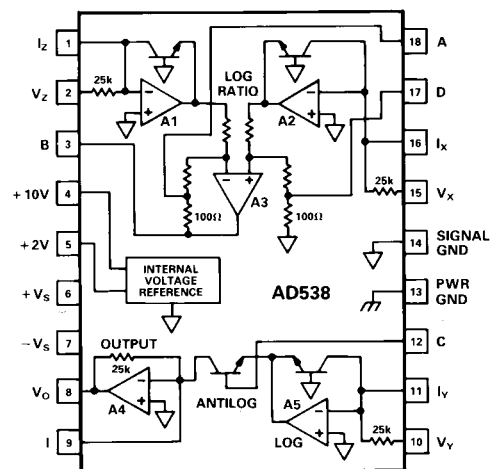

Figure 1. Block diagram and pin connections of the AD538.

Functions are determined by the choice of inputs and appropriate connections of the device's pins. In some cases, one or two external resistors will be required. In addition to the overall transfer function, the constituent log-ratio and antilog functions—and the reference—are available for independent use.

## IN THIS ISSUE

Volume 19, Number 1, 1985 – 28 Pages

AD538 Breaks through with multiple analog functions . . . . .	Cover
Editor's Notes, ADI Authors . . . . .	2
<i>Complete Monolithic Analog Multifunction Chip,</i> <i>Output = Y (Z/X)<sup>M</sup> (AD538) . . . . .</i>	3
<i>Dual 12-Bit Microprocessor-Compatible DAC in 0.3" DIP (AD7549) . . . . .</i>	7
<i>24 x 24-Bit Fixed-Point CMOS Digital Multiplier (ADSP-1024) . . . . .</i>	8
<i>Low-Cost Voltage-to-Frequency Converter Chip (AD654) . . . . .</i>	10
<i>High-Performance Precision Hybrid Isolation Amplifier (AD295) . . . . .</i>	12
<i>New Plug-In Signal-Conditioning Modules for 3B Series (3B47, 3B17) . . . . .</i>	13
<i>Double-Buffered 14-Bit Monolithic CMOS Multiplying DAC (AD7535) . . . . .</i>	14
<i>Low-Cost 8-Bit Monolithic ADC Converts in 1.36μs Max (AD7820) . . . . .</i>	15
<i>Software-Programmable-Gain Amplifier-Track/Hold for</i> <i>Data-Acquisition (AD365) . . . . .</i>	16
<i>High-Performance 10-Bit, 800-ns A/D Converter (AD ADC-816) . . . . .</i>	17
<i>Real-World I/O Cards for the CMOS STD BUS (RTI-1280/1281/1282) . . . . .</i>	18
<i>Thermometer with Resolution Better than 0.0001°C . . . . .</i>	20
New-Product Briefs:	
Fast 8-Bit Monolithic CMOS ADC Converts in 10μs (AD7576) . . . . .	22
Low-Cost 12-Bit Resolver-to-Digital Converter (2S20) . . . . .	22
New Options in HDG 4-to-8-Bit Raster DAC Family . . . . .	22
Thermocouple Amplifiers in Cerdip for Types J and K (AD594Q/595Q) . . . . .	23
Precision BiFET Op Amps in Metal and Cerdip (AD611) . . . . .	23
Precision Op Amp with Existing Second Sources (AD OP-37) . . . . .	23
16-Bit Hybrid A/D Converter – 17μs max Conversion Time (AD376) . . . . .	24
Digital-to-Resolver/Synchro Transformers – Low Profile, Low-Frequency . . . . .	24
Hi-Rel for Non-Military Parts – Analog Devices PLUS Program . . . . .	24
More Authors . . . . .	25
New Analog Devices Division Fellow Named: Peter Holloway . . . . .	25
Worth Reading . . . . .	26
Potpourri . . . . .	27
Advertisement: . . . . .	Back Cover

## CHARACTERISTICS

Although its sub-functions can be used independently, the AD538 is designed and specified as a complete analog computing system, with overall performance specified for both voltage and current inputs. Its dynamic range is 80dB for voltage signals—from 1 mV to 10V, and its current input range is 0.1 to 400  $\mu$ A (72dB).

For flexibility, the summing junctions at the inputs of four of the five amplifiers are accessible for external connections. This makes it possible to sum several signals—including feedbacks and signals from current sources—into the same input terminal, and to add offsets or change the scaling for input voltages.

The wide range of dual power-supply voltages that can be used—from  $\pm 18$  volts to  $\pm 4.5$  volts—gives the user many options, including standard  $\pm 15$ -volt supplies, the increasingly popular  $\pm 12$ -volt supplies, and even  $\pm 5$  volts (employing the 2-volt reference connection).

Multifunction devices that nominally perform the  $Y(Z/X)^M$  function have been on the market since 1972, in the form of modules and—later (in less-complete form)—hybrids. The AD538 is the first monolithic IC on the market to perform this function. As Table 1 indicates, though monolithic, it sacrifices neither performance nor completeness—and in fact adds some hitherto unavailable features.

	Monolithic IC (AD538B)	Hybrid IC	Module (433)
Max error (as a multiplier)			
100:1 dynamic range	$\pm 0.5\%$ of output $\pm 250\mu V^A$	50mV <sup>B</sup>	50mV <sup>A</sup>
0 to 10V wide range <sup>C</sup>	$\pm 1.0\%$ of output $\pm 250\mu V^A$	N/S	N/S
Max bandwidth	400 kHz	500 kHz	100 kHz
Internal reference voltage	10 V, 2 V	N/A	9 V
Supply voltage range	$\pm 4.5$ V to $\pm 18$ V	$\pm 12$ V to $\pm 18$ V	
Upper limit	$\pm 18$ V	$\pm 18$ V	$\pm 18$ V
Lower limit	$\pm 4.5$ V	$\pm 12$ V	$\pm 12$ V
Supply current	4.5 mA	10 mA	10 mA
Package	18-pin DIP (IC)	14-pin (.8" $\times$ .5")	1.5" $\times$ 1.5" $\times$ .62"

### NOTES

<sup>A</sup>With NO external trims

<sup>B</sup>With 3 external trims

<sup>C</sup>See Equation 10

Table 1. Examples of salient features of multifunction device technologies.

## HOW IT WORKS

### Logarithm

The upper portion of the circuit shown in Figure 1 computes the logarithm of the ratio of inputs Z and X. The inputs may be either current ( $I_z$  and  $I_x$ ), voltage ( $V_z$  and  $V_x$ ), or any combination. Voltage inputs, applied at the  $V_z$  and  $V_x$  terminals, are converted to current by the (nominally) 25 k $\Omega$  resistors; the resulting currents, flowing through the feedback transdiodes, develop logarithmic voltages at the outputs of A1 and A2. The difference between the output voltages, taken by subtractor A3, is proportional to the logarithm of the ratio of the input voltages. The output of A3 is available at pin 3, labeled "B".

$$V_B = \frac{kT}{q} \ln I_z - \frac{kT}{q} \ln I_x = \frac{kT}{q} \ln \frac{V_z}{V_x} \quad (2)$$

k is Boltzmann's constant, q is the charge on an electron ( $k/q = 86.17\mu V/K$ ), and T is absolute temperature in kelvins ( $^{\circ}C + 273.2K$ ). At  $T = 300K$  ( $26.8^{\circ}C$ ),  $V_B = 25.85mV$  for each power of  $e$ , or 59.52mV per decade. This voltage constitutes a basic logarithmic output; however it would be useful: to scale the 60-millivolt output to a more convenient level, to compensate for the 86  $\mu V/K$  (or 3,330 ppm) temperature sensitivity

( $dV_B/dT = 86.17\mu V/K$ ), and to buffer the output. This can be readily done, as will be seen in the Applications section.

### Antilogarithm

For multiplication and division, it is necessary to add a voltage representing the logarithm of  $V_y$  or  $I_y$ , and take the antilogarithm, or exponential. This operation is performed in the lower portion of Figure 1. The total input current at the summing point of amplifier A5, determined by  $V_y$ ,  $I_y$ , and/or any additive currents from sources wired to that point, flows through the feedback transdiode and develops a negative voltage at the output of A5 proportional to the logarithm of that current.

Amplifier A4 is connected to perform a current-to-voltage conversion, which results in an antilogarithmic operation. With C (pin 12) grounded, and no offset current added at I (pin 9), the output voltage will be equal to the effective Y-input voltage (all currents at  $I_y$  referred to  $V_y$ ). When C is connected to the log-ratio output of A3 (B), its positive voltage is summed in series with the transdiode base-emitter voltage drops, and A4 performs the balancing operation (inputs and outputs of this section referred to  $V_y$  and  $V_o$ ):

$$V_C + \frac{kT}{q} \ln \frac{V_y}{V_o} = 0 \quad (3)$$

therefore,

$$\frac{qV_C}{kT} = \ln \frac{V_o}{V_y} \quad \text{and} \quad V_o = V_y e^{\frac{qV_C}{kT}}$$

$V_C$  may be derived from an external voltage for direct antilogarithmic operations; however, in the case of multiplication and division, since  $V_C = V_B$  and, from (2),

$$V_B = \frac{kT}{q} \ln \frac{V_z}{V_x} \quad (4) \quad \text{then} \quad V_o = V_y \frac{V_z}{V_x} \quad (5)$$

### Powers and roots

If the output of A3 is amplified (by connecting resistance between terminals A and D to attenuate its feedback), or attenuated (by connecting a voltage divider between B and C), the gain or attenuation of the log signal affects the exponent of the  $(Z/X)$  term. If M is the multiplication factor of the resistor-programmed gain or attenuation, Equation (4) becomes

$$V_C = M V_B' = M \frac{kT}{q} \ln \frac{V_z}{V_x} \quad (6)$$

where  $V_B'$  is the voltage at B when  $M = 1$ . Thus, Equation (1), expressed in voltage, is:

$$V_o = V_y \left[ \frac{V_z}{V_x} \right]^M \quad (7)$$

When the AD538 is used for two-variable analog division (ratios)—or powers and roots—the  $V_y$  input is used to set a convenient scale factor. Amplifier A4 buffers and scales the antilog section output. The output amplifier's summing junction has been made available to provide for offsetting or external trimming of the output stage—and to allow direct connection of the log-ratio section to this stage, thus permitting it to provide the amplified, buffered output of a straight log amplifier.

### Reference

At pins 4 and 5 are output voltages from a stable (15ppm/ $^{\circ}C$  typical) bandgap voltage reference, provided to eliminate the need for an external source of the necessary reference voltages. The reference portion of the AD538 makes available +10 volts (buffered) and +2 volts at the tap of a 5:1, 20-k $\Omega$  laser-trimmed voltage di-



