

GROUND RULES FOR HIGH-SPEED CIRCUITS

Layout and Wiring Are Critical in Video-Converter Circuits

How to Keep Interference to a Minimum

by Don Brockman and Arnold Williams

In recent issues, Analog Dialogue has dealt extensively with topics in shielding and grounding,^{1,2} emphasizing the techniques needed to protect the integrity and precision of analog signals in the dc and audio-frequency domain from interfering signals, whether at line frequency or at much higher frequencies. To complement those articles, we suggest here the elements of good practice for high-resolution "video-speed" converters, i.e., converters of 10-bit or greater resolution, operating at word rates above 1 MHz.

Electronics may be frustrating for designers who cross the threshold from low-resolution-low-speed to high-resolution-high-speed designs, or from digital to analog-signal-conditioning circuits. For them, it often seems the "ground rules" have changed.

Experienced designers can readily attest to the difficulty of obtaining consistent grounds. They can relate stories about the ground that wasn't where they thought it was, or the ground that wasn't there at all, despite a conviction that "it has to be." On printed-circuit (p-c) boards, wires and/or runs that seemed to be perfectly good grounds are transformed into inductors or worse in high-speed or high-frequency circuits.

At ADI's Computer Labs Division, where high-speed circuits are its bread-and-butter, applications engineers have found that grounding is the focus of a large percentage of questions from designers making their initial foray into high-speed circuits. In most cases, the designers encountered difficulties as the result of being unaware of—or ignoring—certain basic ground rules.

BASIC PC-CARD RULES

Knowledgeable high-speed circuit designers have learned that every square inch of a printed-circuit board which doesn't contain circuits or conducting runs should be ground plane. Violating that simple rule invites disaster. But sometimes, strict adherence to the rule is still no guarantee of success if circuit density is too high; then one must reduce the density and create more "real estate" for the ground plane.

Our applications engineers strongly recommend that all breadboard designs be done on double-sided copper-clad boards. Although this is not a sure cure for ground problems, it improves the designer's chances.

Another basic rule for working with high-speed and/or high-frequency printed-circuit-board designs is to connect analog ground and digital ground together within the PC board. This technique is used, for example in Analog Devices card-level high-speed a/d converters (e.g., MOD-1005, MOD-1020, MOD-1205, CAV-0920, and CAV-1210*). Connecting the two grounds enhances the performance of the converters when they are operated either by themselves or as tightly knit subsystems. However, it can raise some system-level problems, to be discussed below.

Another rule for printed-circuit-board designs containing analog and digital circuitry is to use every available spare pin for making

ground connections, and to use those pins to separate the analog and digital signals entering or leaving the board.

Avoid using purely insulating (e.g., "Vector") breadboards and small-diameter hookup wire (e.g., #24) for connections, including supply voltages and grounds. The approach will create ground and noise problems if the circuit is intended to operate at 1 MHz or more (it will probably lead to problems at even slower speeds).

To summarize: Use double-sided copper-clad boards with maximum ground area and heavy, well-located power-supply and ground-return leads. Tie grounds together locally.

GENERAL CIRCUIT PRACTICE

Any subsystem or circuit layout operating at high speeds with both analog and digital signals needs to have those signals physically separated as much as possible to prevent possible crosstalk between the two. Digital signals leaving or entering the layout should use runs that have minimum length. The shorter the digital runs, the lower the likelihood of coupling to the analog circuits.

Analog signals should be routed as far from digital signals as size constraints allow; and the two, ideally should never closely parallel one another's paths. If they must cross, they should do so at right angles to minimize interference. Coaxial cables may be necessary for analog inputs or outputs—a demanding condition mechanically, but sometimes the only solution electrically.

When combining track-and-hold and a/d-converter hybrids or modules on the same board, keep them as close together as is practical. All grounds need to be connected to the single, low-impedance ground plane; and the connections should be made right at the units themselves (another argument for having large amounts of good, solid ground plane available all over the p-c board).

A suggested practical approach for accomplishing this is illustrated in Figure 1, which shows a flow-chart layout, as the preferred method for combining high-speed analog and digital circuits on a p-c board.

If one assumes a 10-volt input range on the 12-bit a/d converter, the least-significant bit (LSB) of the ADC will have a value of 2.5 mV (10 V/4,096). Assume that a single pin of the p-c connector, which is used for ground, has a resistance of 0.05 ohm—and that the p-c card draws a total of 1.5 amperes.

The voltage drop at the ground pin could be 75 millivolts in these circumstances. If only digital logic were used, this voltage drop would be minuscule, hardly worth considering. However, the hypothetical real-world situation being considered here is a mixture of both analog and digital circuits, and the 75 mV can have a significant impact on the subsystem's performance.

¹Alan Rich, "Understanding Interference-Type Noise," *Analog Dialogue* 16-3, 1982, pages 16-19.

²Alan Rich, "Shielding and Guarding," *Analog Dialogue* 17-1, 1983, pages 8-13.

In this example, the digital circuits are TTL. Since TTL is a saturated logic, ground currents vary widely, and varying current flowing through the ground often produces noise signals which modulate the ground plane. This noise, created by digital switching, can couple into the analog portion of the circuit and have an important effect on performance, even at low digital levels. For example, if only 10% of the 75-millivolt I-R drop cited here couples into the analog signal, that would represent 3 LSBs.

The result? The circuit intended for operation as a 12-bit system is now reduced to a system of 10 to 11 bits, because of noise masking the 2.5-millivolt level of the desired 12-bit LSB. The recommended solution? Assign multiple pins for ground connections, to reduce the total contact resistance. As Figure 1 shows, those pins are also used to separate the analog and digital signals.

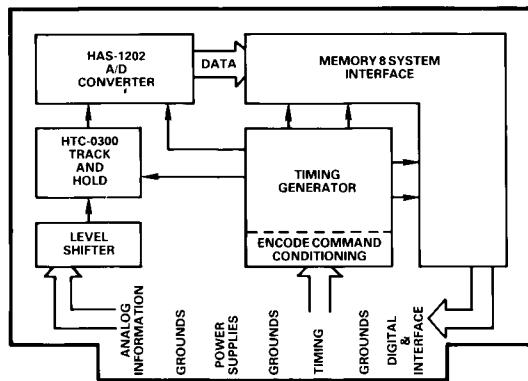

Figure 1. "Flow-Chart" layout for logical separation of functions.

This design approach may seem unnecessarily rigorous and time-consuming but can prove rewarding when the p-c board is installed in its final system location.

Locate the timing circuits near the center of the board (Figure 1) because the timing is at the heart of the circuit, being connected to all of the major circuit components of the board. A central location helps assure minimum paths for the digital signals.

Variations of this theme may not use the exact same components or functions, but the same basic techniques should be applied in any design containing analog and digital circuits. For cards with all connections at one end, avoid configurations which have analog circuits near the p-c connector, and digital signals at the opposite end of the card—or vice versa; either situation will cause analog and digital paths to pass in close proximity to one another.

SYSTEM GROUNDING

Although local ties for analog and digital grounds help the performance of a card, they can cause problems for the system designer using ADCs and DACs. In systems, data converters should be considered as *analog* (not digital) components; the system design must be assigned to experienced and capable *analog* engineers, who are used to defending millivolt signals against interference.

Place ADCs and DACs (like other analog devices) near other parts of the analog section, because: (1) reflections make it hard to transmit analog signals more than a short distance without loss of bandwidth and amplitude; and (2) noise generated by the digital section can couple into the analog through the ground plane or power supplies, or radiate to nearby analog components.

Each card in the system should be returned directly to the power supply common, using heavy wire. Where it is mandatory that a card's analog and digital grounds be separated, each should be separately returned to the power supply; don't connect the two grounds and return a single ground line to the power supply.

POWER SUPPLIES

Besides ground rules, designers of high-speed circuits must also consider the rules about power supplies to obtain best results.

Every power-supply line leading into a high-speed p-c card or data-acquisition circuit must be carefully bypassed to its ground return to prevent noise from entering the card. Ceramic capacitors, ranging in value from 0.01 to 0.1 μF , should be used generously in the layout, mounted as closely as possible to the device or circuit being bypassed; and at least one good-quality tantalum capacitor of 3 to 20 μF should be assigned to each power-supply voltage, mounted as near as possible to the incoming power pins to keep potentially high levels of low-frequency ripple off the card.

To some extent, the p-c's power-supply connector pins can introduce noise problems. If their contact resistance is sufficiently high, and a varying current is flowing, the varying IR drop which results is noise and can be coupled into parts of the card. This caution applies especially to +5-volt supplies used to power TTL systems, but the problem can be alleviated with a variation of the rule about multiple pins for making ground connections. Parallel the I-R drops by also using multiple pins for power connections.

Low-noise, low-ripple temperature-stable linear power supplies are the preferred choices for high-speed circuits. Switching power supplies often seem to meet those criteria, including ripple specifications. *But ripple specs are generally expressed in terms of rms*—and the spikes generated in switchers may often produce hard-to-filter, uncontrollable noise peaks with amplitudes of several-hundred millivolts. Their high-frequency components may be extremely difficult to keep out of the ground system.

If switchers cannot be avoided for high-speed designs, they should be carefully shielded and located as far away from the "action" as possible, and their outputs should be filtered heavily.

ABOUT IC DESIGNS

There is often a difference in implementing designs using high-precision IC circuits vis-à-vis p-c card designs using modules or hybrids. Some ICs are specifically designed to keep analog and digital grounds separated within the device, because they would be unable to perform their functions properly without the separation.

Recognizing this, IC manufacturers are generally very careful in detailing how to obtain optimum performance from their devices. Those details of the application notes frequently instruct the user to connect analog and digital grounds for the device together externally; when they do, the connection needs to be made as closely as possible to the device. In other, much rarer, instances, the characteristics of an individual device—or system—may require some remote connection of the grounds.

The best approach for getting optimum performance from any device is to follow diligently the recommendations of the manufacturer. If the recommendations are missing or vague, ask for them.

Logical signal flow generates logical treatment of ground paths and ground connections—a logical way to prevent potential problems. ▀