

RELIABILITY REPORT
FOR
MAX4172ExA
PLASTIC ENCAPSULATED DEVICES

January 23, 2003

MAXIM INTEGRATED PRODUCTS

120 SAN GABRIEL DR.

SUNNYVALE, CA 94086

Written by



Jim Pedicord
Quality Assurance
Reliability Lab Manager

Reviewed by



Bryan J. Preeshl
Quality Assurance
Executive Director

Conclusion

The MAX4172 successfully meets the quality and reliability standards required of all Maxim products. In addition, Maxim's continuous reliability monitoring program ensures that all outgoing product will continue to meet Maxim's quality and reliability standards.

Table of Contents

I.Device Description	V.Quality Assurance Information
II.Manufacturing Information	VI.Reliability Evaluation
III.Packaging Information	
IV.Die InformationAttachments

I. Device Description

A. General

The MAX4172 is a low-cost, precision, high-side current-sense amplifier for portable PCs, telephones, and other systems where battery/DC power-line monitoring is critical. High-side power-line monitoring is especially useful in battery-powered systems, since it does not interfere with the battery charger's ground path. Wide bandwidth and ground-sensing capability make the MAX4172 suitable for closed-loop battery-charger and general-purpose current-source applications. The 0V and 32V input common-mode range is independent of the supply voltage, which ensures that current-sense feedback remains viable, even when connected to a battery in deep discharge.

To provide a high level of flexibility, the MAX4172 functions with an external sense resistor to set the range of load current to be monitored. It has a current output that can be converted to a ground-referred voltage with a single resistor, accommodating a wide range of battery voltages and currents.

An open-collector power-good output (/PG) indicates when the supply voltage reaches an adequate level to guarantee proper operation of the current-sense amplifier. The MAX4172 operates with a 3.0V to 32V supply voltage.

B. Absolute Maximum Ratings

<u>Item</u>	<u>Rating</u>
V+, RS+, RS-, /PG	-0.3V to +36V
OUT	-0.3V to (V+ + 0.3V)
Differential Input Voltage, $V_{RS+} - V_{RS-}$	$\pm 700\text{mV}$
Current into Any Pin	$\pm 50\text{mA}$
Storage Temp.	-65°C to $+150^{\circ}\text{C}$
Lead Temp. (10 sec.)	$+300^{\circ}\text{C}$
Continuous Power Dissipation (TA = $+70^{\circ}\text{C}$)	
8-Lead μMAX	330mW
8-Lead NSO	471mW
Derate above $+70^{\circ}\text{C}$	
8-Lead μMAX	4.10mW/ $^{\circ}\text{C}$
8-Lead NSO	5.88mW/ $^{\circ}\text{C}$

II. Manufacturing Information

A. Description/Function:	Low-Cost, Precision, High-Side Current-Sense Amplifier
B. Process:	SG3 - Standard 3 micron silicon gate CMOS
C. Number of Device Transistors:	177
D. Fabrication Location:	Oregon, USA
E. Assembly Location:	Malaysia, Philippines or Thailand
F. Date of Initial Production:	December, 1996

III. Packaging Information

A. Package Type:	8 Lead μ MAX	8-Lead NSO
B. Lead Frame:	Copper	Copper
C. Lead Finish:	Solder Plate	Solder Plate
D. Die Attach:	Silver-filled Epoxy	Silver-filled Epoxy
E. Bondwire:	Gold (1.3 mil dia.)	Gold (1.3 mil dia.)
F. Mold Material:	Epoxy with silica filler	Epoxy with silica filler
G. Assembly Diagram:	Buildsheet # 05-3001-0063	Buildsheet # 05-3001-0062
H. Flammability Rating:	Class UL94-V0	Class UL94-V0
I. Classification of Moisture Sensitivity per JEDEC standard JESD22-A112:	Level 1	Level 1

IV. Die Information

A. Dimensions:	84 x 58 mils
B. Passivation:	$\text{Si}_3\text{N}_4/\text{SiO}_2$ (Silicon nitride/ Silicon dioxide)
C. Interconnect:	Aluminum/Si (Si = 1%)
D. Backside Metallization:	None
E. Minimum Metal Width:	3 microns (as drawn)
F. Minimum Metal Spacing:	3 microns (as drawn)
G. Bondpad Dimensions:	5 mil. Sq.
H. Isolation Dielectric:	SiO_2
I. Die Separation Method:	Wafer Saw

V. Quality Assurance Information

- A. Quality Assurance Contacts: Jim Pedicord (Reliability Lab Manager)
Bryan Preeshl (Executive Director of QA)
Kenneth Huening (Vice President)
- B. Outgoing Inspection Level: 0.1% for all electrical parameters guaranteed by the Datasheet.
0.1% For all Visual Defects.
- C. Observed Outgoing Defect Rate: < 50 ppm
- D. Sampling Plan: Mil-Std-105D

VI. Reliability Evaluation

A. Accelerated Life Test

The results of the 135°C biased (static) life test are shown in **Table 1**. Using these results, the Failure Rate (λ) is calculated as follows:

$$\lambda = \frac{1}{\text{MTTF}} = \frac{1.83}{192 \times 4389 \times 160 \times 2} \quad (\text{Chi square value for MTTF upper limit})$$

▲
Temperature Acceleration factor assuming an activation energy of 0.8eV

$$\lambda = 6.79 \times 10^{-9} \quad \lambda = 6.79 \text{ F.I.T. (60\% confidence level @ 25°C)}$$

This low failure rate represents data collected from Maxim's reliability qualification and monitor programs. Maxim also performs weekly Burn-In on samples from production to assure reliability of its processes. The reliability required for lots which receive a burn-in qualification is 59 F.I.T. at a 60% confidence level, which equates to 3 failures in an 80 piece sample. Maxim performs failure analysis on rejects from lots exceeding this level. The Burn-In Schematic 06-5243 shows the static circuit used for this test. Maxim also performs 1000 hour life test monitors quarterly for each process. This data is published in the Product Reliability Report (**RR-1M**) located on the Maxim website at <http://www.maxim-ic.com>.

B. Moisture Resistance Tests

Maxim evaluates pressure pot stress from every assembly process during qualification of each new design. Pressure Pot testing must pass a 20% LTPD for acceptance. Additionally, industry standard 85°C/85%RH or HAST tests are performed quarterly per device/package family.

C. E.S.D. and Latch-Up Testing

The OP11 die type has been found to have all pins able to withstand a transient pulse of $\pm 400\text{V}$, per Mil-Std-883 Method 3015 (reference attached ESD Test Circuit). Latch-Up testing has shown that this device withstands a current of $\pm 250\text{mA}$ and/or $\pm 20\text{V}$.

Table 1
Reliability Evaluation Test Results

MAX4172ExA

TEST ITEM	TEST CONDITION	FAILURE IDENTIFICATION	PACKAGE	SAMPLE SIZE	NUMBER OF FAILURES
Static Life Test (Note 1)					
	Ta = 135°C Biased Time = 192 hrs.	DC Parameters & functionality		160	0
Moisture Testing (Note 2)					
Pressure Pot	Ta = 121°C P = 15 psi. RH= 100% Time = 168hrs.	DC Parameters & functionality	uMax NSO	77	0
				77	0
85/85	Ta = 85°C RH = 85% Biased Time = 1000hrs.	DC Parameters & functionality		77	0
Mechanical Stress (Note 2)					
Temperature Cycle	-65°C/150°C 1000 Cycles Method 1010	DC Parameters & functionality		77	0

Note 1: Life Test Data may represent plastic D.I.P. qualification lots.

Note 2: Generic Process/Package Data

Attachment #1

TABLE II. Pin combination to be tested. 1/ 2/

	Terminal A (Each pin individually connected to terminal A with the other floating)	Terminal B (The common combination of all like-named pins connected to terminal B)
1.	All pins except V_{PS1} 3/	All V_{PS1} pins
2.	All input and output pins	All other input-output pins

1/ Table II is restated in narrative form in 3.4 below.

2/ No connects are not to be tested.

3/ Repeat pin combination I for each named Power supply and for ground (e.g., where V_{PS1} is V_{DD} , V_{CC} , V_{SS} , V_{BB} , GND , $+V_S$, $-V_S$, V_{REF} , etc).

3.4 Pin combinations to be tested.

- a. Each pin individually connected to terminal A with respect to the device ground pin(s) connected to terminal B. All pins except the one being tested and the ground pin(s) shall be open.
- b. Each pin individually connected to terminal A with respect to each different set of a combination of all named power supply pins (e.g., V_{SS1} , or V_{SS2} or V_{SS3} or V_{CC1} , or V_{CC2}) connected to terminal B. All pins except the one being tested and the power supply pin or set of pins shall be open.
- c. Each input and each output individually connected to terminal A with respect to a combination of all the other input and output pins connected to terminal B. All pins except the input or output pin being tested and the combination of all the other input and output pins shall be open.

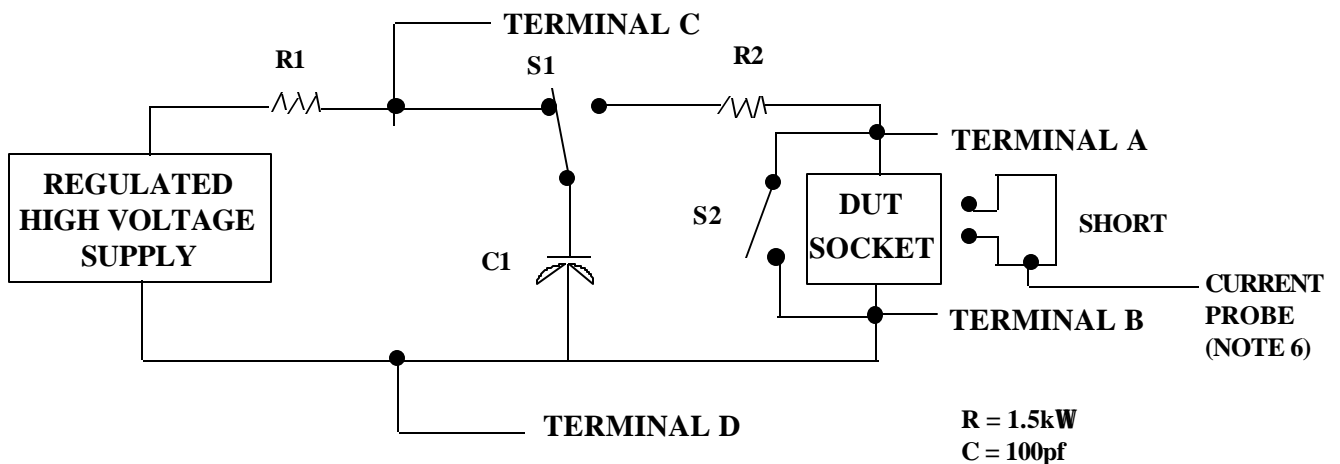

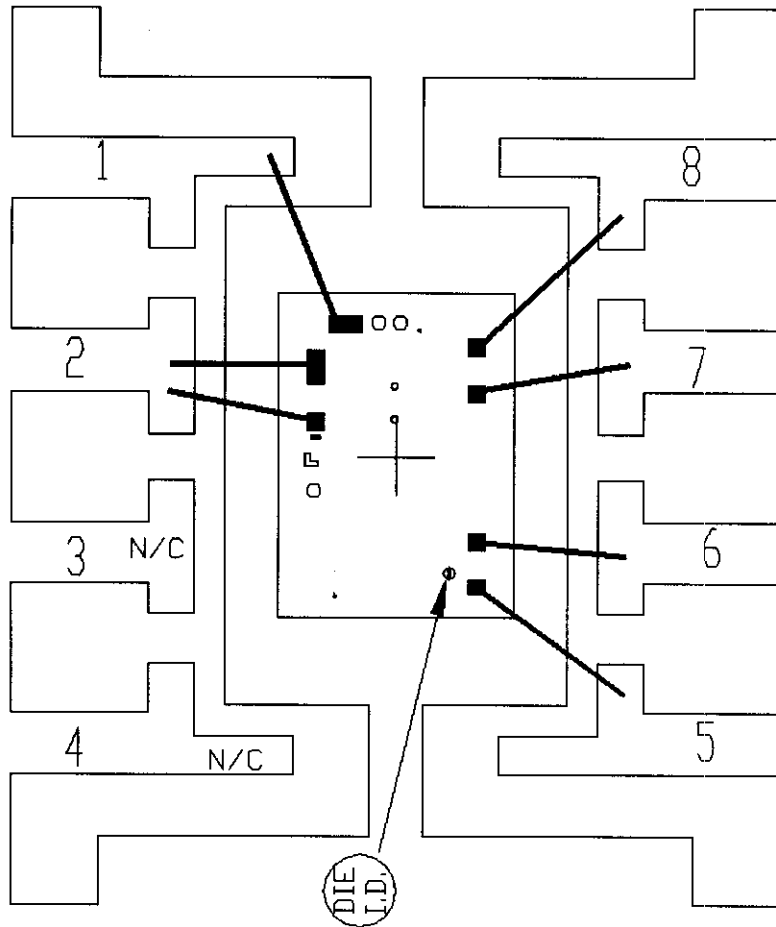

PKG.CODE: S8-4		APPROVALS	DATE	MAXIM
CAV./PAD SIZE: 90 X 130	PKG. DESIGN			BUILDSHEET NUMBER: 05-3001-0062 REV.: A

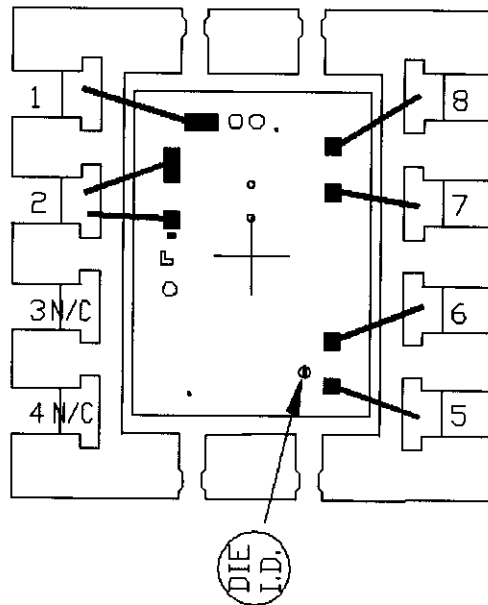

PKG. CODE: U8-1		APPROVALS	DATE	MAXIM	
CAV./PAD SIZE: 68X94	PKG. DESIGN			BUILDSHEET NUMBER: 05-3001-0063	REV.: A

ONCE PER BOARD

ONCE PER DEVICE

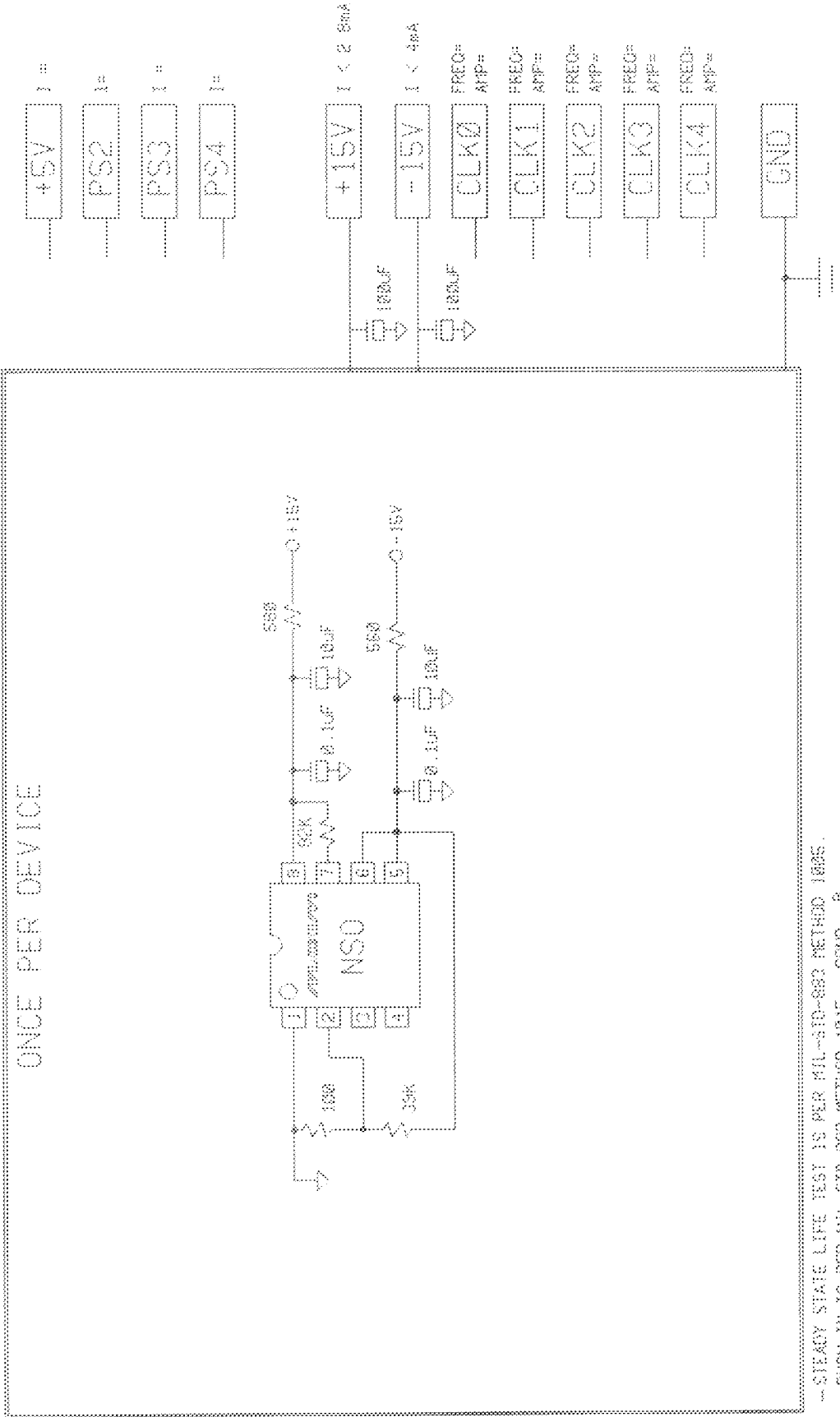

--STEADY STATE LIFE TEST IS PER MIL-STD-883 METHOD 1005.
 --BURN-IN IS PER MIL-STD-883 METHOD 1015, COND. B

NOTES:

1. TEMPERATURE: 125C OR EQUIVALENT
2. TIME: 100 HOURS MIN. OR EQUIVALENT
3. ALL COMPONENTS AND MATERIAL MUST STAND 150C CONTINUOUS
4. APPROVED FOR CXJ COMMERCIAL ENV HR/89J

SPEC. NO. 06-5243 REV: A

MAXIM BURN-IN SCHEMATIC

DEVICE TYPE(s):

DATE: 10/28/96

MAX4172

DRAWN BY: