

IN THIS ISSUE



12

4- and 6-supply monitors feature $\pm 1.5\%$ accuracy for rails down to 1.2V **17**

4mm x 7mm IC produces multiple power rails from a single Li-ion cell **26**

passive mixers increase gain and decrease noise in downconverter apps **39**

Ultralow Voltage Energy Harvester Uses Thermoelectric Generator for Battery-Free Wireless Sensors

David Salerno

The proliferation of ultralow power wireless sensor nodes for measurement and control, combined with new energy harvesting technology, has made it possible to produce completely autonomous systems that are powered by local ambient energy instead of batteries. Powering a wireless sensor node from ambient or “free” energy is attractive because it can supplement or eliminate the need for batteries or wires. This is a clear benefit when battery replacement or servicing is inconvenient, costly or dangerous.

A complete lack of wires also makes it easy to expand monitoring and control systems on a large scale. Energy harvesting wireless sensor systems simplify installation and maintenance in such diverse areas as building automation, wireless/automated metering and predictive maintenance, as well as numerous other industrial, military, automotive and consumer applications.

The benefits of energy harvesting are clear, but an effective energy harvesting system requires a clever power management scheme to convert the miniscule levels of free energy into a form usable by the wireless sensor system.

IT'S ALL ABOUT THE DUTY CYCLE

Many wireless sensor systems consume very low average power, making them prime candidates to be powered by energy harvesting techniques. Many sensor nodes are used to monitor physical quantities that change slowly. Measurements can therefore be taken and transmitted infrequently, resulting in a low duty cycle of operation and a correspondingly low average power requirement.

(continued on page 2)

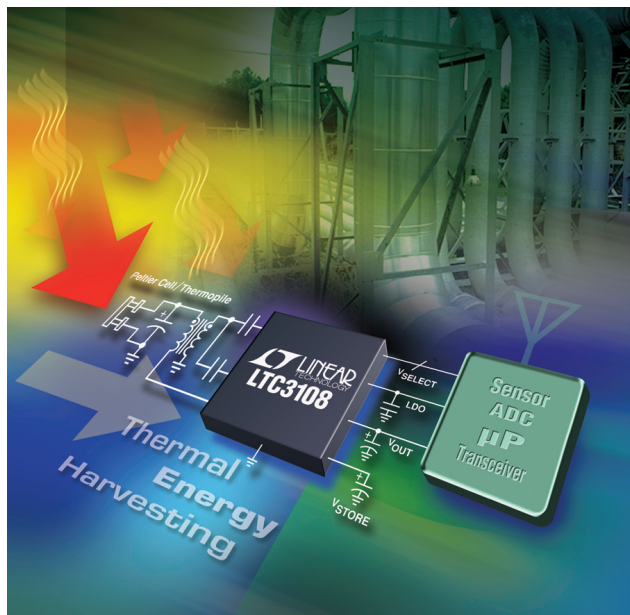

In this issue...

COVER STORY

Ultralow Voltage Energy Harvester Uses Thermoelectric Generator for Battery-Free Wireless Sensors
David Salerno

1

DESIGN FEATURES

POL μ Module DC/DC Converter Operates from Inputs Down to 1.5V, Delivering Up to 15A Output, Without an Auxiliary Bias Supply
Jason Sekanina and Alan Chern

12

4- and 6-Supply Monitors Feature $\pm 1.5\%$ Accuracy and Watchdog Timers for Rails Down to 1.2V
A. Ng

17

Accurate Constant-Current, Constant-Voltage 20A Power Supply Ensures Safe Charging of Supercaps and Li-Ion Batteries
Josh Caldwell

23

4mm \times 7mm IC Produces Seven Regulated Outputs and a Dual-String LED Driver
Aspiyan Gazder

26

DESIGN IDEAS

Battery-Free Power Backup System Uses Supercapacitors to Prevent Data Loss in RAID Systems
Jim Drew

31

True Grid Independence: Robust Energy Harvesting System for Wireless Sensors Uses Piezoelectric Energy Harvesting Power Supply and Li-Poly Batteries with Shunt Charger
George H. Barbehenn

36

Passive Mixers Increase Gain and Decrease Noise When Compared to Active Mixers in Downconverter Applications
Tom Schiltz, Bill Beckwith, Xudong Wang and Doug Stuetzle

39

product briefs

42

back page circuits

44

The missing link in the energy harvesting system chain has been the power converter/power management block that can operate from one or more of the common sources of free energy. The LTC3108 and other Linear energy harvesting parts fill in this missing link.

For example, if a sensor system requires 3.3V at 30mA (100mW) while awake, but is only active for 10ms out of every second, then the average power required is only 1mW, assuming the sensor system current is reduced to microamps during the inactive time between transmit bursts. If the same wireless sensor only samples and transmits once a minute instead of once a second, the average power plummets under 20 μ W. This difference is significant, because most forms of energy harvesting offer very little steady-state power; usually no more than a few milliwatts, and in some cases only microwatts. The less average power required by an application, the more likely it can be powered by harvested energy.

ENERGY HARVESTING SOURCES

The most common sources of energy available for harvesting are vibration (or motion), light and heat. The transducers for all of these energy sources have three characteristics in common:

- Their electrical output is unregulated and doesn't lend itself to being used directly for powering electronic circuits
- They may not provide a continuous, uninterrupted source of power
- They generally produce very little average output power, usually in the range of 10 μ W to 10mW.

These characteristics demand judicious power management if the source is going to be useful in powering wireless sensors or other electronics.

POWER MANAGEMENT: THE MISSING LINK IN ENERGY HARVESTING—UNTIL NOW

A typical wireless sensor system powered by harvested energy can be broken down into five fundamental blocks, as illustrated in Figure 1. With the exception of the power management block, all of these blocks have been commonly available for some time. For example, microprocessors that run on microwatts of power, and small, cost effective RF transmitters and transceivers that also consume very little power are widely available. Low power analog and digital sensors are also ubiquitous.

(continued on page 4)

Figure 1. Typical wireless sensor block diagram

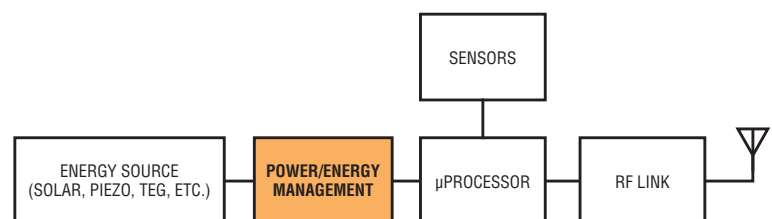

An ideal power management solution for energy harvesting should be small, easy to apply and perform well from the exceptionally high or low voltages produced by common energy harvesting sources.

(LTC3108, continued from page 2)

The missing link in completing this energy harvesting system chain has been the power converter/power management block that can operate from one or more of the common sources of free energy. An ideal power management solution for energy harvesting should be small, easy to apply and perform well while operating from the exceptionally high or low voltages produced by common energy harvesting sources, ideally providing a good load match to the source impedance for optimal power transfer. The power manager itself must require very little current

to manage the accumulated energy and produce regulated output voltages with a minimal number of discrete components.

The LTC3108, available in either a 3mm × 4mm × 0.75mm 12-pin DFN or 16-pin SSOP package, solves the energy harvesting problem for ultralow input voltage applications. It provides a compact, simple, highly integrated monolithic power management solution for operation from input voltages as low as 20mV. This unique capability enables it to power wireless sensors from a thermoelectric generator (TEG), harvesting energy from

temperature differentials (ΔT) as small as 1°C. Using a small (6mm × 6mm), off-the-shelf step-up transformer and a handful of low cost capacitors, it provides the regulated output voltages necessary for powering today's wireless sensor electronics.

The LTC3108 uses a step-up transformer and an internal MOSFET to form a resonant oscillator capable of operating from very low input voltages. With a transformer ratio of 1:100, the converter can start up with inputs as low as 20mV. The transformer secondary winding feeds a charge pump and rectifier circuit, which is used to

Figure 2. Block diagram of the LTC3108

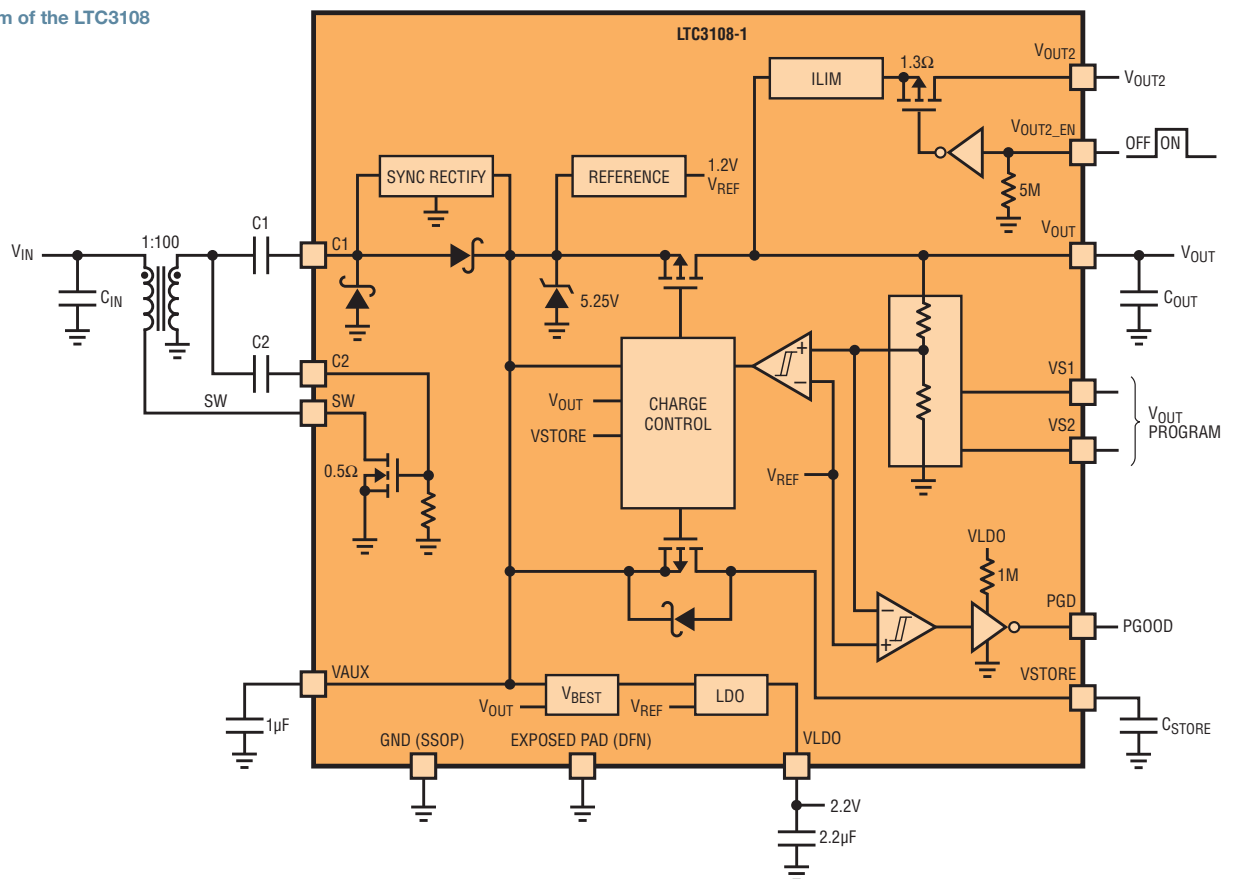
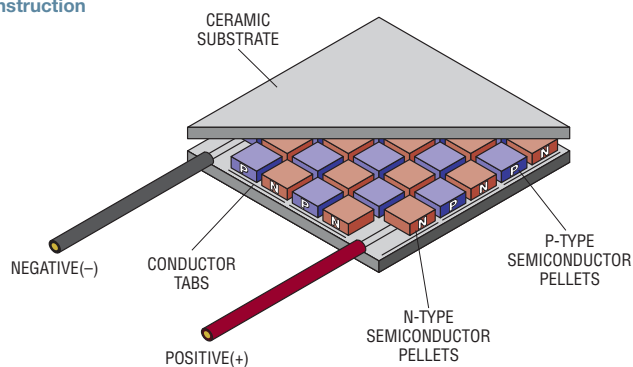

Figure 4. TEG construction



power the IC (via the V_{AUX} pin) and charge the output capacitors. The 2.2V LDO output is designed to be in regulation first, to power a low power microprocessor as soon as possible. After that, the main output capacitor is charged to the voltage programmed by the $VS1$ and $VS2$ pins (2.35V, 3.3V, 4.1V or 5.0V) for powering sensors, analog circuitry, RF transceivers or even charging a supercapacitor or battery. The V_{OUT} reservoir capacitor supplies the burst energy required during the low duty cycle load pulse when the wireless sensor is active and transmitting. A switched output (V_{OUT2}), easily controlled by the host, is also provided for powering circuits that don't have a shutdown or low power sleep mode. A power good output is included to alert the host that the main output voltage is close to its regulated value. Figure 2 shows a block diagram of the LTC3108. The LTC3108-1 is identical to the LTC3108 except that it provides a different set of selectable output voltages (2.5V, 3.0V, 3.7V or 4.5V.)

Once V_{OUT} is charged and in regulation, harvested current is diverted to the V_{STORE} pin for charging an optional large storage capacitor or rechargeable battery. This storage element can be used to maintain regulation and power the system in the event that the energy harvesting source is intermittent. The output voltage sequencing during power-up and power-down can be seen in Figure 3. A shunt regulator on the V_{AUX} pin prevents V_{STORE} from charging above 5.3V.

Using a typical 40mm square TEG, the LTC3108 can operate from a ΔT as low as

1°C, making it useful for a wide variety of energy harvesting applications. A higher ΔT results in the LTC3108 being able to supply a higher average output current.

TEG BASICS

Thermoelectric generators (TEGs) are simply thermoelectric modules that convert a temperature differential across the device, and resulting heat flow through it, into a voltage via the Seebeck effect. The reverse of this phenomenon, known as the Peltier effect, produces a temperature differential by applying a voltage and is familiarly used in thermoelectric coolers (TECs). The polarity of the output voltage is dependent on the polarity of the temperature differential across the TEG. Reverse the hot and cold sides of the TEG and the output voltage changes polarity.

TEGs are made up of pairs or couples of N-doped and P-doped semiconductor pellets connected electrically in series and sandwiched between two thermally

conductive ceramic plates. The most commonly used semiconductor material is bismuth-telluride (Bi_2Te_3). Figure 4 illustrates the mechanical construction of a TEG.

Some manufacturers differentiate between a TEG and a TEC. When sold as a TEG, it generally means that the solder used to assemble the couples within the module has a higher melting point, allowing operation at higher temperatures and temperature differentials, and therefore higher output power than a standard TEC (which is usually limited to a maximum of 125°C). Most low power harvesting applications do not see high temperatures or high temperature differentials.

TEGs come in a wide variety of sizes and electrical specifications. The most common modules are square, ranging in size from about 10mm to 50mm per side. They are usually 2mm–5mm thick.

A number of variables control how much voltage a TEG will produce for a given ΔT (proportional to the Seebeck coefficient). Their output voltage is in the range of 10 mV/K to 50mV/K of differential temperature (depending on the number of couples), with a source resistance in the range of 0.5 Ω to 5 Ω . In general, the more couples a TEG has in series, the higher its output voltage is for a given ΔT . However, increasing the number of couples also increases the series resistance of the TEG, resulting in a larger voltage drop when loaded. Manufacturers can

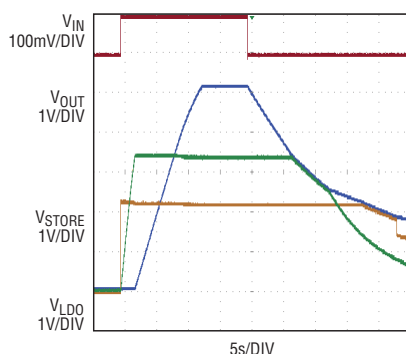

Figure 3. Voltage sequencing during power-up and power-down

A good rule of thumb when selecting a thermoelectric module for power generation purposes is to choose the module with the highest product of ($V_{MAX} \cdot I_{MAX}$) for a given size.

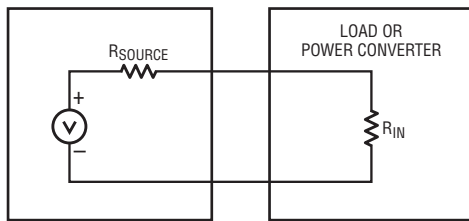

Figure 5. Simplified schematic of a voltage source driving a resistive load

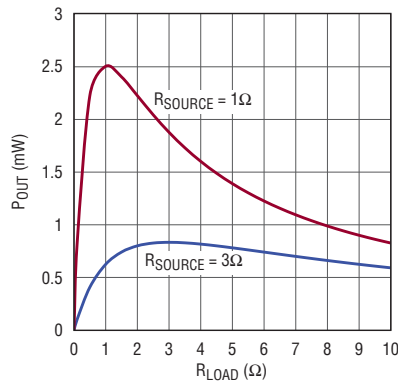

Figure 6. Output power from the source as a function of load resistance

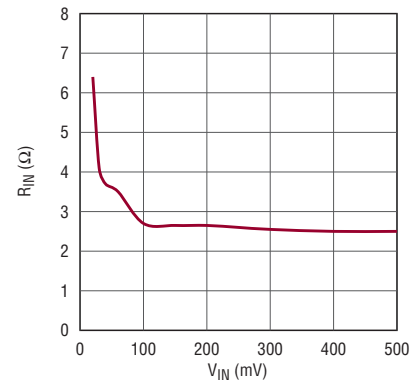

Figure 7. Input resistance vs V_{IN} (1:100 ratio) for the LTC3108

compensate for this by adjusting the size and design of the individual pellets to preserve a low resistance while still providing a higher output voltage.

LOAD MATCHING

To extract the maximum amount of power available from any voltage source, the load resistance must match the internal resistance of the source. This is illustrated in the example of Figure 5, where a source voltage with an open-circuit voltage of 100mV and a source resistance of either 1Ω or 3Ω is driving a load resistor. Figure 6 shows the power delivered to the load as a function of load resistance. It can be seen in each curve that maximum power is delivered to the load when the load resistance matches the source resistance. Nevertheless, it is also important to note that when the source resistance is *lower* than the load resistance, the power delivered may not be the maximum possible but is still higher (1.9mW in this example) than a higher source resistance driving a matched load (0.8mW in this example). This is why

choosing a TEG with the lowest electrical resistance provides the most output power.

The LTC3108 presents a minimum input resistance of about 2.5Ω to the input source. (Note that this is the input resistance of the converter, not the IC itself.) This falls in the middle of the range of most TEG source resistances, providing a good load match for nearly optimal power transfer. The design of the LTC3108 is such that as V_{IN} drops, the input resistance increases (shown in Figure 7). This feature allows the LTC3108 to adapt reasonably well to TEGs with different source resistances.

Since the converter input resistance is fairly low, it draws current from the source, regardless of load. For example, Figure 8 shows that with a 100mV input, the converter draws about 37mA from the source. This input current is not to be confused with the 6μA of quiescent current required by the IC itself (off of V_{AUX}) to power its internal circuitry. The low quiescent current is most meaningful

during start-up at the minimum voltage, or when operating from a storage capacitor.

CHOOSING A TEG FOR POWER GENERATION

Most thermoelectric module manufacturers do not provide data for output voltage or output power versus differential temperature, which is what the designer of a thermal energy harvester wants to see. Two parameters that are always provided are V_{MAX} and I_{MAX} , which are the maximum operating voltage and maximum operating current for a particular module (when being driven in a heating/cooling application).

A good rule of thumb when selecting a thermoelectric module for power generation purposes is to choose the module with the highest product of ($V_{MAX} \cdot I_{MAX}$) for a given size. This generally provides the highest TEG output voltage and the lowest source resistance. One caveat to this rule is that the heat sink must be sized according to the size of the TEG. Larger TEGs require larger heat sinks for optimal performance.

The LTC3109 is uniquely suited to the challenge of harvesting energy from sources of either polarity. Using transformers with a step-up ratio of 1:100, it can operate from input voltages as low as $\pm 30\text{mV}$.

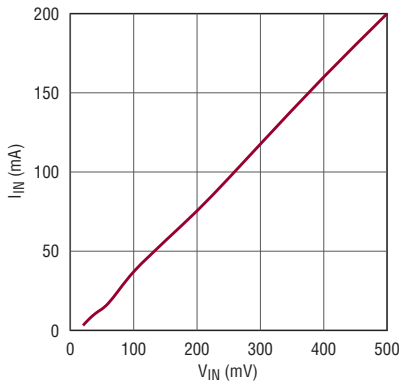

Figure 8. Input current vs V_{IN} (1:100 ratio) for the LTC3108

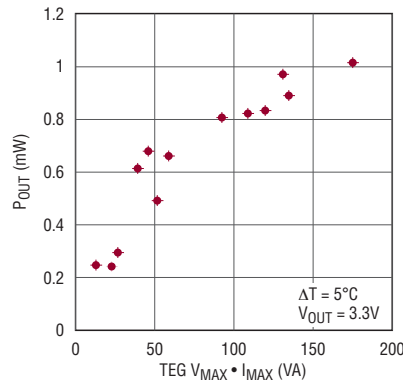

Figure 9. LTC3108 output power vs TEGs with different VI products

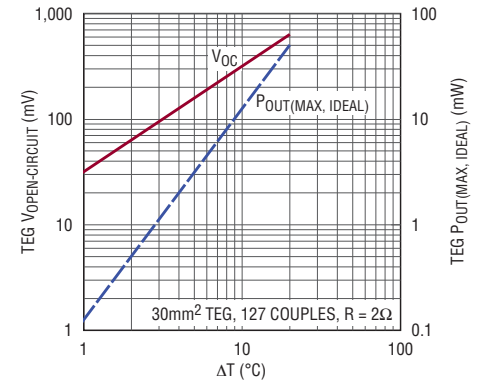

Figure 10. Open-circuit voltage and maximum power output from a typical TEG

Note that the electrical resistance, if given, is specified as an AC resistance because it cannot be measured in the conventional manner using a DC current, as DC current causes a Seebeck voltage to be generated, which yields erroneous resistance readings. Figure 9 is a plot of the power output from the LTC3108 using thirteen different TEGs at a fixed ΔT of 5°C versus the ($V_{MAX} \cdot I_{MAX}$) product for each module. It can be seen that higher VI products generally result in higher output power from the LTC3108.

Figure 10 shows the output voltage and maximum output power capability for a 30mm^2 TEG over a ΔT range of 1°C to 20°C . The output power varies from hundreds of microwatts to tens of milliwatts over this range. Note that this power curve assumes an ideal load match, with no conversion losses. Ultimately, the available output power after being boosted to a higher voltage by the LTC3108 is less due to power conversion losses. The LTC3108 data sheet provides several graphs of available output power over several different operating conditions.

The size of the TEG required for a given application depends on the minimum ΔT available, and the maximum average power required by the load, as well as the thermal resistance of the heat sink being used to maintain one side of the TEG at ambient. The maximum power output of the LTC3108 is in the range of $15\mu\text{W}/\text{K}\cdot\text{cm}^2$ to $30\mu\text{W}/\text{K}\cdot\text{cm}^2$, depending on transformer turns ratio and the specific TEG chosen. Some recommended TEG part numbers are provided in Table 1.

THERMAL CONSIDERATIONS

When placing a TEG between two surfaces at different temperatures, the “open circuit” temperature differential, before the TEG is added, is higher than the temperature differential across the TEG when it’s in place. This is due to the fact that the TEG itself has a fairly low thermal resistance between its plates (typically $1^\circ\text{C}/\text{W}$ to $10^\circ\text{C}/\text{W}$).

For example, consider a situation where a large piece of machinery is running with a surface temperature of 35°C and a

surrounding ambient temperature of 25°C . When a TEG is attached to the machinery, a heat sink must be added to the cool (ambient) side of the TEG, otherwise the entire TEG would heat up to nearly 35°C , erasing any temperature differential. Keep in mind that it is the heat flow through the TEG that produces electrical output power.

In this example, the thermal resistance of the heat sink and the TEG dictate what portion of the total ΔT exists across the TEG. A simple thermal model of the system is illustrated in Figure 11. Assuming that the thermal resistance of the heat source (R_S) is negligible, the thermal resistance of the TEG (R_{TEG}) is $2^\circ\text{C}/\text{W}$, and the thermal resistance of the heat sink is $8^\circ\text{C}/\text{W}$, the resulting ΔT across the TEG is only 2°C . The low output voltage from a TEG with just a few degrees across it highlights the importance of the LTC3108’s capability to operate from Ultralow input voltages.

Note that large TEG’s usually have a lower thermal resistance than smaller ones due to the increased surface area. Therefore,

in applications where a relatively small heat sink is used on one side of the TEG, a larger TEG may have less ΔT across it than a smaller one, and therefore may not necessarily provide more output power. In any case, using a heat sink with the lowest possible thermal resistance maximizes the electrical output by maximizing the temperature drop across the TEG.

SELECTING THE OPTIMAL TRANSFORMER TURNS RATIO

For applications where higher temperature differentials (i.e. higher input voltages) are available, a lower turns ratio transformer, such as 1:50 or 1:20, can be used to provide higher output current capability. As a rule of thumb, if the minimum input voltage is at least 50mV under load, then a 1:50 ratio is recommended. If the minimum input voltage is at least 150mV, then a 1:20 ratio is recommended. All of the ratios discussed are available as off-the-shelf parts from Coilcraft (please refer to the LTC3108 data sheet for more information, including specific

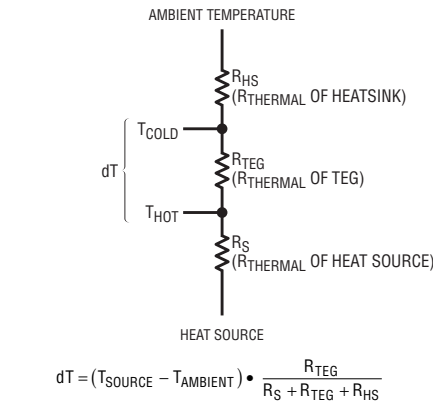

Figure 11. Thermal resistance model of a TEG and heatsink

part numbers). The curves in Figure 12 show the output power capability of the LTC3108 over a range of temperature differentials, using two different transformer step-up ratios and two different size TEGs.

PULSED LOAD APPLICATION

A typical wireless sensor application powered by a TEG is shown in Figure 13. In this example a temperature differential of at least 2°C is available across the TEG,

so a 1:50 transformer ratio was chosen for the highest output power in the range of 2 to 10 degrees ΔT . Using the TEG shown (a 40mm square device with a resistance of 1.25 Ω), this circuit can start-up and charge the V_{OUT} capacitor from temperature differentials of as little as 2°C. Note that there is a bulk decoupling capacitor across the input terminals of the converter. Providing good decoupling of the voltage from the TEG minimizes input ripple, improving output power capability and allowing start-up at the lowest possible ΔT .

In the example of Figure 13, the 2.2V LDO output powers the microprocessor, while V_{OUT} has been programmed to 3.3V, using the VS1 and VS2 pins, to power the RF transmitter. The switched V_{OUT} (V_{OUT2}) is controlled by the microprocessor to power 3.3V sensors only when needed. The PGOOD output lets the microprocessor know when V_{OUT} has reached 93% of its regulated value. To maintain operation in the absence of an input voltage, a 0.1F storage capacitor

Table 1. Recommended TEG part numbers by size and manufacturer/distributor

	15MM	20MM	30MM	40MM
CUI INC (Distributor)	CP60133	CP60233	CP60333	CP85438
FERROTEC	9501/031/030 B	9501/071/040 B	9500/097/090 B	9500/127/100 B
FUJITAKA	FPH13106NC	FPH17106NC	FPH17108AC	FPH112708AC
KRYOTHERM			TGM-127-1.0-0.8	LCB-127-1.4-1.15
LAIRD TECHNOLOGY			PT6.7.F2.3030.W6	PT8.12.F2.4040.TA.W6
MARLOW INDUSTRIES		RC3-8-01	RC6-6-01	RC12-8-01LS
TELLUREX	C2-15-0405	C2-20-0409	C2-30-1505	C2-40-1509
TE TECHNOLOGY	TE-31-1.0-1.3	TE-31-1.4-1.15	TE-71-1.4-1.15	TE-127-1.4-1.05

With their unique ability to operate at input voltages as low as 20mV, or from very low voltages of either polarity, the LTC3108 and LTC3109 provide simple, effective power management solutions that enable thermal energy harvesting for powering wireless sensors and other low power applications from common thermoelectric devices.

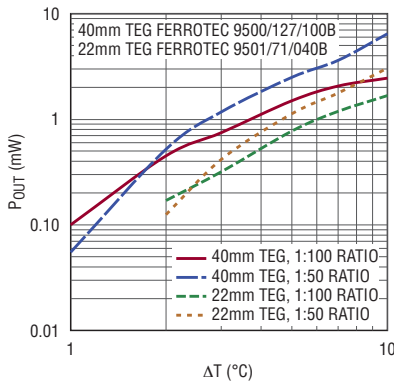

Figure 12. LTC3108 output power vs ΔT for two sizes of TEG and two transformer ratios for $V_{OUT} = 5V$

is charged in the background from the V_{STORE} pin. This capacitor can charge all the way up to the 5.25V clamp voltage of the V_{AUX} shunt regulator. In the event that the input voltage source is lost, energy is automatically supplied by the storage capacitor to power the IC and maintain regulation of V_{LDO} and V_{OUT} .

In this example, the C_{OUT} reservoir capacitor has been sized to support a total load pulse of 15mA for a duration of 10ms, allowing for a 0.33V drop in V_{OUT} during the load pulse, according to the formula below. Note that I_{PULSE} includes loads on V_{LDO} and V_{OUT2} as well as V_{OUT} , and that charging current available is not included, as it may be very small compared to the load.

$$C_{OUT}(\mu F) = \frac{I_{PULSE}(\text{mA}) \cdot t_{PULSE}(\text{ms})}{dV_{OUT}}$$

Given these requirements, C_{OUT} must be at least 454 μF , so a 470 μF capacitor was selected.

With the TEG shown, operating at a ΔT of 5°C, the average charge current available from the LTC3108 at 3.3V is about 560 μA . With this information, we can calculate how long it takes to charge the V_{OUT} reservoir cap the first time, and how frequently the circuit can transmit a pulse. Assuming the load on V_{LDO} and V_{OUT} is very small (relative to 560 μA) during the charging phase, the initial charge time for V_{OUT} is:

$$t_{CHARGE} = \frac{470\mu F \cdot 3.3V}{560\mu A} = 2.77 \text{ seconds}$$

Assuming that the load current between transmit pulses is very small, a simple way to estimate the maximum transmit rate allowed is to divide the average output power available from the LTC3108, in this case $3.3V \cdot 560\mu A = 1.85mW$, by the power required during a pulse, in this case $3.3V \cdot 15mA = 49.5mW$. The maximum duty cycle that the harvester can support is $1.85mW/49.5mW = 0.037$ or 3.7%. Therefore the maximum transmit burst rate is $0.01/0.037 = 0.27$ seconds or about 3.7Hz.

Keep in mind that if the average load current (as determined by the transmit rate) is the highest that the harvester can support, there will be no harvested energy left over to charge the storage capacitor (if storage capability is desired). Therefore, in this example the transmit rate is set to 2Hz, leaving almost half of the available energy to charge the storage capacitor. In this case, the storage time provided by the V_{STORE} capacitor is calculated using the following formula:

$$t_{STORE} = \frac{0.1F \cdot (5.25V - 3.3V)}{6\mu A + 15mA \cdot \frac{0.01}{0.5}} = 637 \text{ seconds}$$

This calculation includes the 6 μA quiescent current required by the LTC3108, and assumes that the loading between transmit pulses is extremely small. In this case, once the storage capacitor reaches full charge, it can support the load for 637 seconds at a transmit rate of 2Hz, or a total of 1274 transmit bursts.

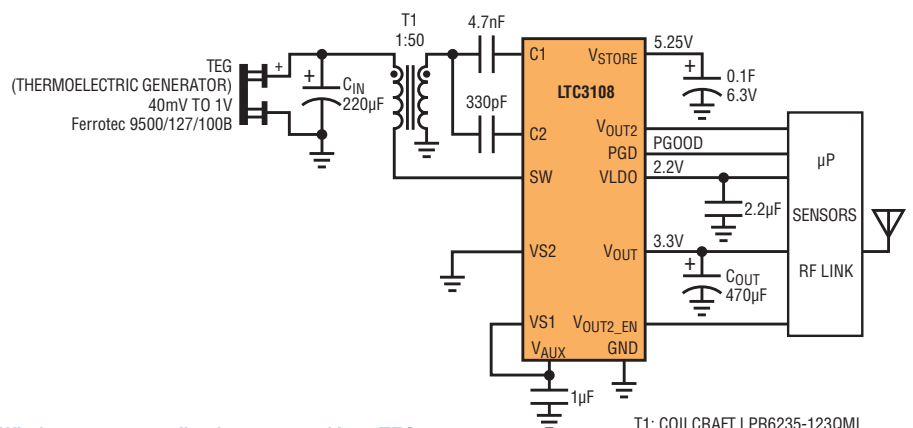

Figure 13. Wireless sensor application, powered by a TEG

T1: COILCRAFT LPR6235-123QML

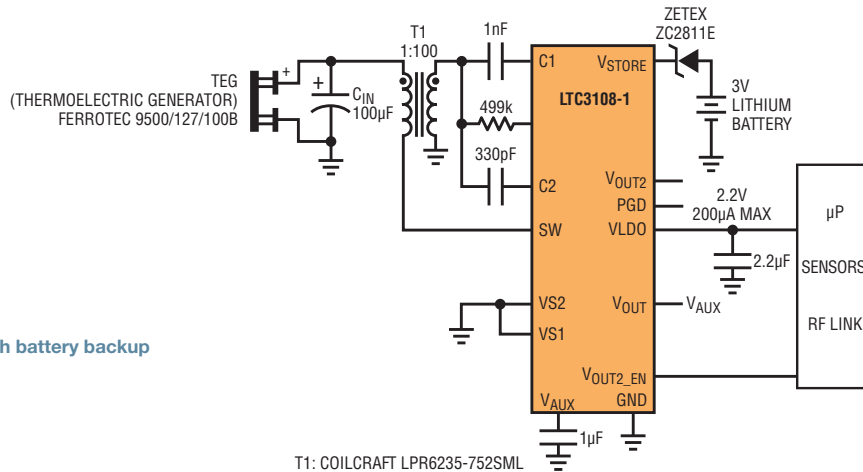

Figure 14. Energy harvester with battery backup

ULTRALOW POWER APPLICATION WITH BATTERY BACKUP

Some applications may not have a pulsed load, but may operate continuously. Such applications are traditionally powered by a small primary battery, such as a 3V lithium coin cell. If the power demand is low enough these applications can be powered continuously by thermal harvesting, or may use thermal harvesting to greatly extend the life of the battery, reducing maintenance costs.

Figure 14 shows an energy harvesting application with battery backup to drive a continuous load. In this example, where all the electronics are powered entirely from

the 2.2V LDO output and consume less than 200µA total, the LTC3108 can power the load continuously as long as a temperature differential of at least 3°C exists across the TEG. Under these conditions, there is no load on the battery. For times when there is insufficient harvested energy available, the 3V lithium battery seamlessly takes over and powers the load.

ENERGY STORAGE ALTERNATIVES

For applications that choose to use a rechargeable battery instead of a primary battery for backup or energy storage, the diode in Figure 14 can be removed and the lithium battery can be replaced by a nickel-based rechargeable or a Li-ion

battery (including the new thin-film lithium rechargeables). If a nickel-based rechargeable battery is used, its self-discharge current must be smaller than the average charge current the LTC3108 can provide. If a Li-ion battery is chosen, additional circuitry is required to protect it from over-charge and over-discharge. Yet another storage alternative would be a supercapacitor with a 5.25V rating, such as the Cooper-Bussman PB-5ROH104-R. Supercapacitors offer the benefit of a higher number of charge/discharge cycles than rechargeable batteries but have much lower energy density.

Figure 15. Autopolarity energy harvester-powered wireless sensor node

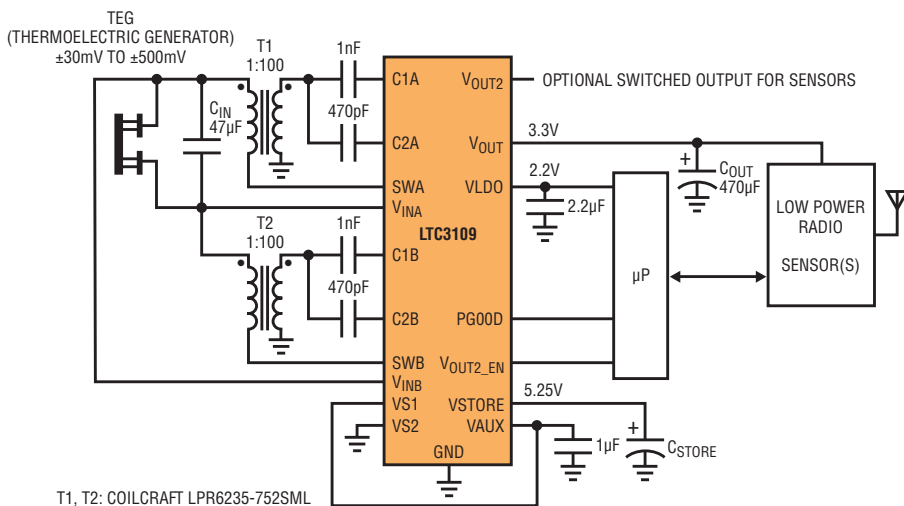

T1, T2: COILCRAFT LPR6235-752SML

Figure 16. Output current vs Vin for the converter in Figure 15

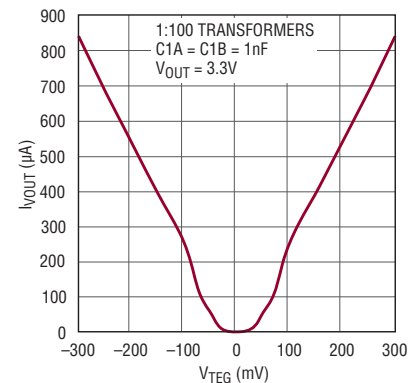

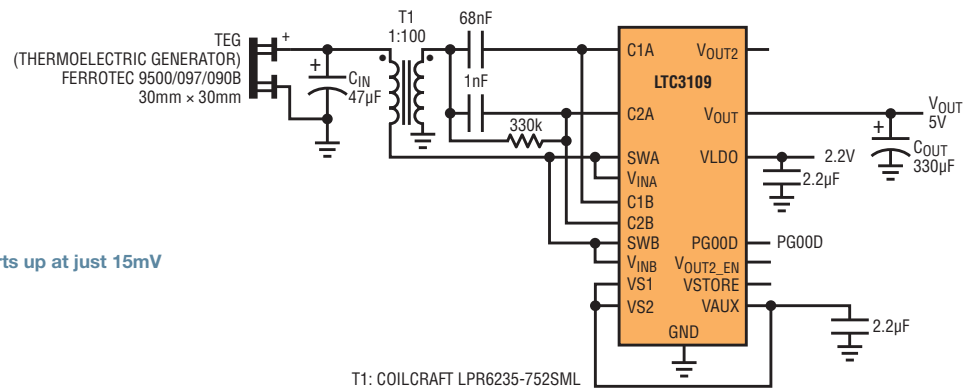

Figure 17. Unipolar converter using the LTC3109 starts up at just 15mV

THERMAL HARVESTING APPLICATIONS REQUIRING AUTOPOLARITY

Some applications, such as wireless HVAC sensors or geothermal powered sensors present another unique challenge to an energy harvesting power converter. These applications require that the energy harvesting power manager be able to operate not only from a very low input voltage, but one of either polarity as the polarity of the ΔT across the TEG changes. This is a particularly challenging problem, and at voltages in the tens or hundreds of millivolts, diode bridge rectifiers are not an option.

The LTC3109 is uniquely suited to the challenge of harvesting energy from sources of either polarity. Using transformers with a step-up ratio of 1:100, it can operate from input voltages as low as $\pm 30\text{mV}$. The LTC3109 offers the same feature set as the LTC3108, including an LDO, a digitally programmable output voltage, a power good output, a switched output and an energy storage output. The LTC3109 is available in either a 4mm \times 4mm 20-pin QFN package or a 20-pin SSOP package. A typical example of the LTC3109 being used in an autopolarity application is shown in Figure 15. Output current vs V_{IN} curves for the converter are shown in Figure 16, and illustrate the ability to function equally well from input voltages of either polarity.

The LTC3109 can also be configured for unipolar operation, using a single transformer (like the LTC3108) to satisfy those applications requiring the lowest possible startup voltage and the highest possible output current. The circuit shown in Figure 17 starts up at just 15mV, which occurs at a differential temperature of less than 1°C using the TEG shown. At a temperature differential of 10°C it can deliver a regulated 5V at 0.74mA for 3.7mW of regulated steady state output power. This is almost double the output power of the LTC3108 under the same conditions, as shown in Figure 18.

Note that in the unipolar configuration, the LTC3109 presents a load resistance of about 1Ω to the TEG, so it's important to choose a TEG with very low source resistance for good load matching, otherwise there will be no benefit to using the LTC3109 in a unipolar configuration. The TEG used in this example has a nominal source resistance of 1.0Ω for optimal power transfer.

CONCLUSION

With their unique ability to operate at input voltages as low as 20mV, or from very low voltages of either polarity, the LTC3108 and LTC3109 provide simple, effective power management solutions that enable thermal energy harvesting for powering wireless sensors and other low power applications from common thermoelectric devices. Available in either a 12-pin DFN or 16-pin SSOP package (LTC3108 and LTC3108-1), and 20-pin QFN or SSOP packages (LTC3109), these products offer unprecedented low voltage capabilities and a high level of integration to minimize the solution footprint. The LTC3108, LTC3108-1 and LTC3109 interface seamlessly with existing low power building blocks to support autonomous wireless sensors and extend the battery life in critical battery backup applications. ■

Figure 18. Comparison of LTC3108 output with LTC3109 output in unipolar configuration

