

# DESIGN NOTES

## Current-Limited DC/DC Converter Simplifies USB Power Supplies – Design Note 252

Bryan Legates

Many portable universal serial bus (USB) devices power themselves from the USB host or hub power supply when plugged into the USB port. Several requirements must be met to ensure the integrity of the bus: the USB specification dictates that the input capacitance of a device must be less than  $10\mu\text{F}$  to minimize inrush currents when the device is plugged into the USB port; when first plugged in, the device must draw less than 100mA from the port, and for high power devices, the current drawn from the port can increase to 500mA only after it is given permission to do so by the USB controller. These requirements can be easily met using the LT1618 DC/DC converter, which provides an accurate input current control ideal for USB applications. The LT1618 combines a traditional voltage feedback loop with a unique current feedback loop to operate as a constant-current, constant-voltage source.

### USB to 12V Boost Converter

Figure 1 shows a 5V to 12V boost converter ideal for USB applications. The converter has a selectable 100mA/500mA input current limit, allowing the device to be easily switched between the USB low and high power modes. Efficiency, shown in Figure 2, exceeds 85%.

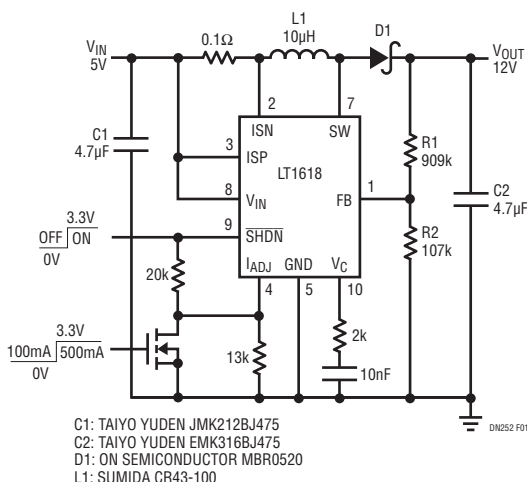

**Figure 1. USB to 12V Boost Converter (with Selectable 100mA/500mA Input Current Limit)**

If the load demands more current than the converter can provide with the input current limited to 100mA (or 500mA), the output voltage will simply decrease and the LT1618 will operate in constant-current mode. For example, with an input current limit of 100mA, around 35mA can be provided to the 12V output. If the load increases to 50mA, the output voltage will reduce to around 8V to maintain a constant 100mA input current.

### USB to 5V SEPIC DC/DC Converter with Short-Circuit Protection

The single-ended primary inductance converter (SEPIC) shown in Figure 3 is ideal for applications where the output must reduce to zero during shutdown. The input current limit not only helps soft-start the output but also provides short-circuit protection, ensuring USB device compliance even under output fault conditions. Figure 4 shows the start-up characteristic of the SEPIC with a 50mA load. By limiting the input current to 100mA, the output is soft-started, smoothly increasing and not overshooting its final 5V value. Figure 5 shows that the input current does not exceed 100mA even with the output shorted to ground (thus the flat output voltage waveform in the picture). Efficiency for this SEPIC converter is shown in Figure 6.

LT, LT, LTC, LTM, Linear Technology and the Linear logo are registered trademarks of Linear Technology Corporation. All other trademarks are the property of their respective owners.

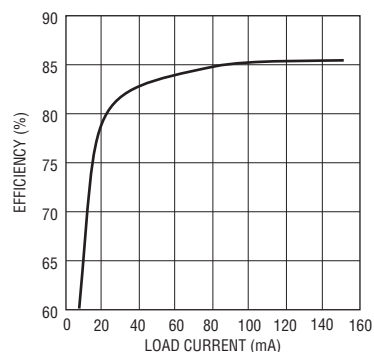

**Figure 2. USB to 12V Boost Efficiency**

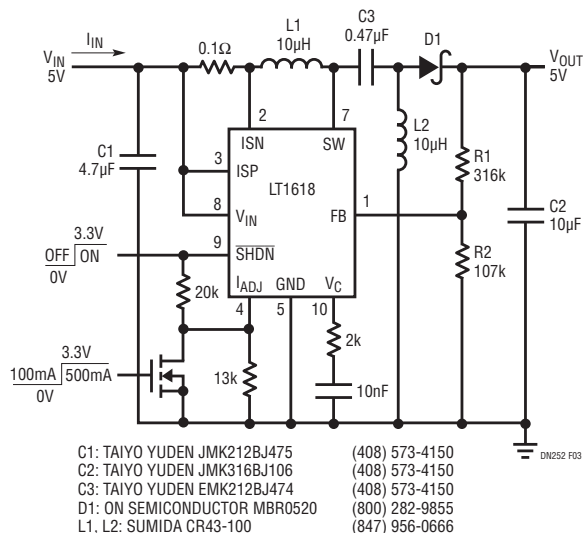

Figure 3. USB to 5V SEPIC Converter

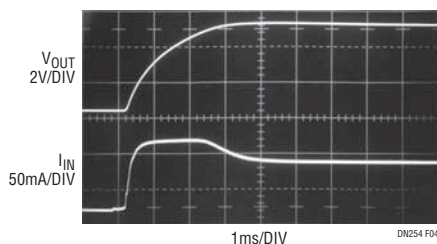

Figure 4. USB SEPIC During Start-Up

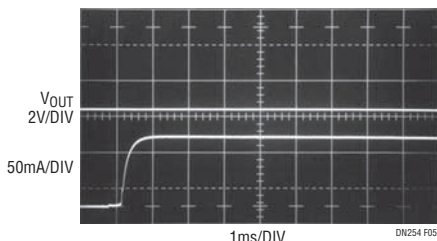

Figure 5. USB SEPIC Start-Up with Output Shorted

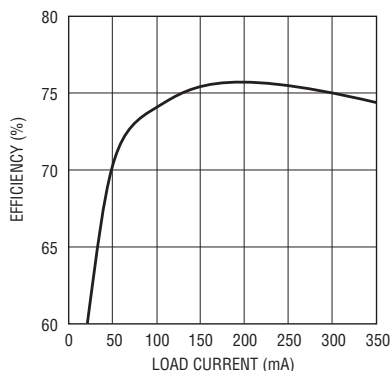

Figure 6. USB to 5V SEPIC Efficiency

## Li-Ion White LED Driver

In addition to providing an accurate input current limit, the LT1618 can also be used to provide a regulated output current for current-source applications. White LED drivers are one such application for which the LT1618 is ideally suited. With an input voltage range of 1.6V to 18V, the LT1618 can provide LED drive from a variety of input sources, including two or more alkaline cells, or one or more Li-Ion cells. The circuit in Figure 7 is capable of driving six white LEDs from a single Li-Ion cell. LED brightness can be adjusted using a pulse width modulated (PWM) signal, as shown, or by using a DC voltage to drive the I<sub>ADJ</sub> pin directly, without the R3/C3 lowpass filter. If brightness control is not needed, simply tie the I<sub>ADJ</sub> pin to ground. Typical output voltage with the LEDs shown is around 22V, and the R1, R2 output divider sets the maximum output voltage to around 26V to protect the LT1618 if the LEDs are disconnected. The LT1618's constant-current loop regulates 50mV across the 2.49Ω sense resistor, setting the LED current to 20mA.

Efficiency for this circuit exceeds 70%, which is significantly higher than the 30% to 50% efficiency obtained when using a charge pump for LED drive. When the LT1618 is turned off, no current flows in the LEDs. Their high forward voltages prevent them from turning on, ensuring a true low current shutdown with no excess battery leakage or light output.

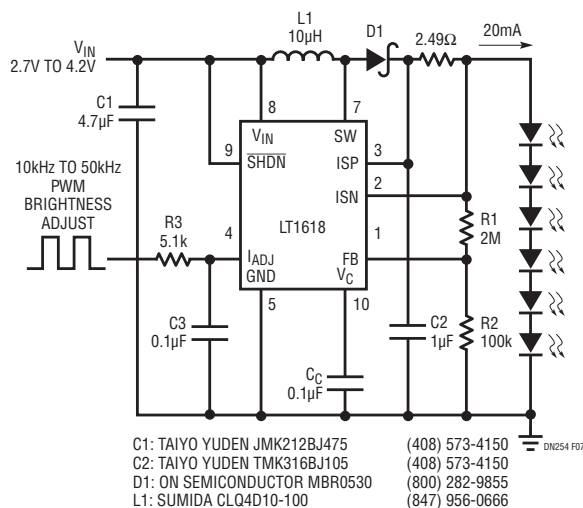

Figure 7. Li-Ion White LED Driver

Data Sheet Download

www.linear.com

For applications help,  
call (408) 432-1900

Linear Technology Corporation  
1630 McCarthy Blvd., Milpitas, CA 95035-7417  
(408) 432-1900 • FAX: (408) 434-0507 • www.linear.com

dn252f\_conv LT/TP 0301 345K • PRINTED IN THE USA

LINEAR TECHNOLOGY  
© LINEAR TECHNOLOGY CORPORATION 2001