

特長

- AD7543/DAC-8143を直接置換えて性能を改善
- 低コスト
- DNLおよびINL(全温度範囲): $\pm 0.5\text{LSB}$
- 使いやすく高速、柔軟なシリアル・インタフェース
- 複数DACシステム(LTC8143)用ディジチェーン3線式インタフェース
- 全温度範囲で1LSBの最大利得誤差を実現、調整が不要
- 初期化用非同期クリア入力
- 4象限乗算
- 低消費電力
- 16ピンPDIPおよびSOパッケージ

アプリケーション

- プロセス・コントロール/産業オートメーション
- リモート・マイクロプロセッサ制御システム
- デジタル的に制御されたフィルタ/電源
- プログラム可能な利得アンプ
- 自動試験装置

概要

LTC[®]7543/LTC8143は、シリアル入力の12ビット乗算型デジタル・アナログ・コンバータ(DAC)です。AD7543およびDAC-8143とピン・コンパチブルですが、より優れた性能を発揮します。精度、温度および電源変動に対する安定性が改善され、出力アンプ・オフセットに対する感度が低減されました。また、タイミング仕様が厳しくなり、出力キャパシタンスも低減されています。

使いやすいシリアル・インタフェースには、既知状態への初期化を必要とするシステム用の非同期CLEAR入力が含まれています。LTC8143は、3線式インタフェース・バス上での複数のDACがディジチェーン可能なシリアル・データ出力を備えています。

これらのDACは非常に用途が広く、2象限および4象限乗算、プログラム可能な利得、非反転電圧出力およびバイアス/オフセット・グラウンド・モードなどの単一電源アプリケーションに使用できます。

LTC7543/LTC8143は、16ピンPDIPおよびSOパッケージで供給され、 $-40 \sim 85$ の拡張工業用温度範囲で仕様が規定されています。

△、LTC、LTIはリニアテクノロジー社の登録商標です。

TYPICAL APPLICATION

Multiplying DAC Has Easy 3-Wire Serial Interface

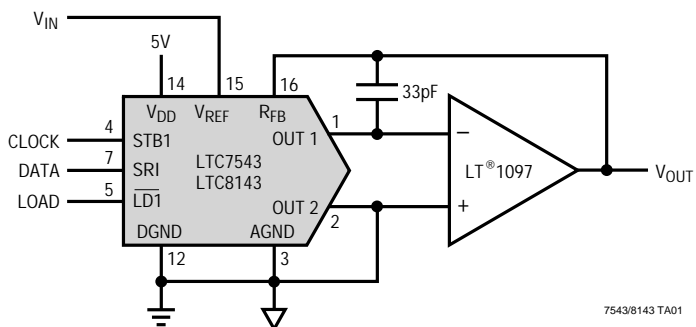

7543/8143 TA01

Integral Nonlinearity over Temperature

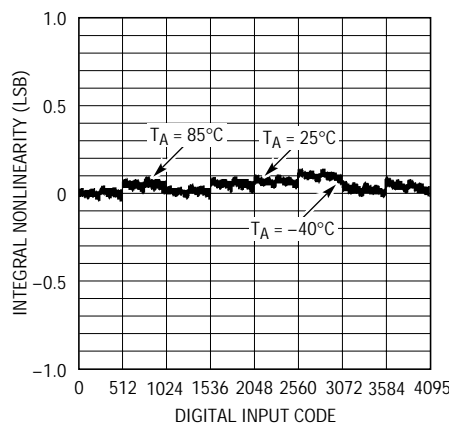

7543/8143 TA02

ABSOLUTE MAXIMUM RATINGS

V_{DD} to AGND	-0.5V to 7V
V_{DD} to DGND	-0.5V to 7V
AGND to DGND	$V_{DD} + 0.5V$
DGND to AGND	$V_{DD} + 0.5V$
Digital Inputs to DGND	-0.5V to ($V_{DD} + 0.5V$)
V_{OUT1} , V_{OUT2} to AGND	-0.5V to ($V_{DD} + 0.5V$)
V_{REF} to AGND, DGND	$\pm 25V$
V_{RFB} to AGND, DGND	$\pm 25V$
Maximum Junction Temperature	150°C
Operating Temperature Range	-40°C to 85°C
Storage Temperature Range	-65°C to 150°C
Lead Temperature (Soldering, 10 sec)	300°C

PACKAGE/ORDER INFORMATION

<p style="text-align: center;">TOP VIEW</p> <p style="text-align: center;">N PACKAGE 16-LEAD PDIP SW PACKAGE 16-LEAD PLASTIC SO WIDE</p> <p style="text-align: center;">$T_{JMAX} = 150^{\circ}C, \theta_{JA} = 100^{\circ}C/W$ (N) $T_{JMAX} = 150^{\circ}C, \theta_{JA} = 130^{\circ}C/W$ (SW)</p>	<p>ORDER PART NUMBER</p> <p>LTC7543GKN LTC7543KN LTC7543GKSW LTC7543KSW LTC8143EN LTC8143FN LTC8143ESW LTC8143FSW</p>
--	---

Consult factory for Military grade parts.

ACCURACY CHARACTERISTICS (LTC7543)

$V_{DD} = 5V$, $V_{REF} = 10V$, $V_{OUT1} = V_{OUT2} = AGND = DGND = 0V$, $T_A = T_{MIN}$ to T_{MAX} , unless otherwise specified.

SYMBOL	PARAMETER	CONDITIONS	LTC7543GK			LTC7543K			UNITS
			MIN	TYP	MAX	MIN	TYP	MAX	
	Resolution		●	12			12		Bits
INL	Integral Nonlinearity (Relative Accuracy)	(Note 1)	●		± 0.5			± 0.5	LSB
DNL	Differential Nonlinearity	Guaranteed Monotonic, T_{MIN} to T_{MAX}	●		± 0.5			± 0.5	LSB
GE	Gain Error	(Note 2) $T_A = 25^{\circ}C$ T_{MIN} to T_{MAX}	●		± 1			± 2	LSB
			●		± 1			± 2	LSB
	Gain Temperature Coefficient ($\Delta Gain/\Delta Temp$)	(Note 3)	●	1	5		1	5	ppm/°C
I_{LKG}	Output Leakage Current	(Note 4) $T_A = 25^{\circ}C$ T_{MIN} to T_{MAX}	●		± 1			± 1	nA
			●		± 10			± 10	nA
	Zero-Scale Error	$T_A = 25^{\circ}C$ T_{MIN} to T_{MAX}	●		± 0.006			± 0.006	LSB
			●		± 0.06			± 0.06	LSB
PSRR	Power Supply Rejection Ratio	$V_{DD} = 5V \pm 5\%$	●	± 0.0001	± 0.002		± 0.0001	± 0.002	%/%

ACCURACY CHARACTERISTICS (LTC8143)

$V_{DD} = 5V$, $V_{REF} = 10V$, $V_{OUT1} = V_{OUT2} = AGND = DGND = 0V$, $T_A = T_{MIN}$ to T_{MAX} , unless otherwise specified.

SYMBOL	PARAMETER	CONDITIONS	LTC8143E			LTC8143F			UNITS
			MIN	TYP	MAX	MIN	TYP	MAX	
	Resolution		●	12			12		Bits
INL	Integral Nonlinearity (Relative Accuracy)	(Note 1)	●			±0.5		±1	LSB
DNL	Differential Nonlinearity	Guaranteed Monotonic, T_{MIN} to T_{MAX}	●			±0.5		±1	LSB
GE	Gain Error	(Note 2) $T_A = 25^\circ C$ T_{MIN} to T_{MAX}	●			±1 ±2		±2 ±2	LSB LSB
	Gain Temperature Coefficient ($\Delta Gain/\Delta Temp$)	(Note 3)	●	1	5		1	5	ppm/ $^\circ C$
I_{LKG}	Output Leakage Current	(Note 4) $T_A = 25^\circ C$ T_{MIN} to T_{MAX}	●			±5 ±25		±5 ±25	nA nA
	Zero-Scale Error	$T_A = 25^\circ C$ T_{MIN} to T_{MAX}	●			±0.03 ±0.15		±0.03 ±0.15	LSB LSB
PSRR	Power Supply Rejection Ratio	$V_{DD} = 5V \pm 5\%$	●			±0.0001 ±0.002		±0.0001 ±0.002	%/%

ELECTRICAL CHARACTERISTICS

$V_{DD} = 5V$, $V_{REF} = 10V$, $V_{OUT1} = V_{OUT2} = AGND = DGND = 0V$, $T_A = T_{MIN}$ to T_{MAX} , unless otherwise specified.

SYMBOL	PARAMETER	CONDITIONS	LTC7543/LTC8143 ALL GRADES			UNITS	
			MIN	TYP	MAX		
Reference Input							
R_{REF}	V_{REF} Input Resistance	(Note 5)	●	8	11	15	k Ω
AC Performance (Note 3)							
	Output Current Settling Time	(Notes 6, 7)	●		0.25	1	μs
	Multiplying Feedthrough Error	$V_{REF} = \pm 10V$, 10kHz Sinewave	●		0.8	2	mV _{p-p}
	Digital-to-Analog Glitch Energy	(Notes 6, 8)	●		2	20	nV-sec
THD	Total Harmonic Distortion	(Note 9)	●		-108	-92	dB
	Output Noise Voltage Density	(Note 10)	●			13	nV/ \sqrt{Hz}
Analog Outputs (Note 3)							
C_{OUT}	Output Capacitance	DAC Register Loaded to All 1s	C_{OUT1}	●	60	90	pF
			C_{OUT2}	●	20	60	pF
		DAC Register Loaded to All 0s	C_{OUT1}	●	30	60	pF
			C_{OUT2}	●	50	90	pF
Digital Inputs							
V_{IH}	Digital Input High Voltage		●	2.4			V
V_{IL}	Digital Input Low Voltage		●		0.8		V
I_{IN}	Digital Input Current	$V_{IN} = 0V$ to V_{DD}	●		0.001	±1	μA
C_{IN}	Digital Input Capacitance	(Note 3), $V_{IN} = 0V$	●			8	pF
Digital Outputs: SRO (LTC8143 Only)							
V_{OH}	Digital Output High	$I_{OH} = -200\mu A$	●	4			V
V_{OL}	Digital Output Low	$I_{OL} = 1.6mA$	●			0.4	V

ELECTRICAL CHARACTERISTICS

$V_{DD} = 5V$, $V_{REF} = 10V$, $V_{OUT1} = V_{OUT2} = AGND = DGND = 0V$, $T_A = T_{MIN}$ to T_{MAX} , unless otherwise specified.

SYMBOL	PARAMETER	CONDITIONS	LTC7543/LTC8143 ALL GRADES			UNITS	
			MIN	TYP	MAX		
Timing Characteristics (Note 3)							
t_{DS1}	Serial Input to Strobe Setup Time ($t_{STB} = 80ns$)	STB1 Used as the Strobe	●	50	5	ns	
t_{DS2}		STB2 Used as the Strobe	●	20	-5	ns	
t_{DS3}		STB3 Used as the Strobe	●	0	-30	ns	
t_{DS4}		STB4 Used as the Strobe	●	0	-30	ns	
t_{DH1}	Serial Input to Strobe Hold Time ($t_{STB} = 80ns$)	STB1 Used as the Strobe	●	30	10	ns	
t_{DH2}		STB2 Used as the Strobe	●	50	25	ns	
t_{DH3}		STB3 Used as the Strobe	●	80	55	ns	
t_{DH4}		STB4 Used as the Strobe	●	80	55	ns	
t_{SRI}	Serial Input Data Pulse Width		●	80		ns	
t_{STB1} , t_{STB2} , t_{STB3} , t_{STB4}	Strobe Pulse Width	(Note 11)	●	80		ns	
$\overline{t_{STB1}}$, $\overline{t_{STB2}}$, $\overline{t_{STB3}}$, $\overline{t_{STB4}}$	Strobe Pulse Width	(Note 12)	●	80		ns	
t_{LD1} , t_{LD2}	Load Pulse Width		●	140		ns	
t_{ASB}	LSB Strobed into Input Register to Load DAC Register Time		●	0		ns	
t_{CLR}	Clear Pulse Width		●	80		ns	
SRO Timing Characteristics (LTC8143 Only)							
t_{PD}	STB2, $\overline{STB3}$, STB4 Strobe to SRO Propagation Delay	$C_L = 50pF$	●	120	220	ns	
t_{PD1}	STB1 to SRO Propagation Delay	$C_L = 50pF$	●	80	150	ns	
Power Supply							
V_{DD}	Supply Voltage		●	4.75	5	5.25	V
I_{DD}	Supply Current	Digital Inputs = 0V or V_{DD}	●			0.1	mA
		Digital Inputs = V_{IH} or V_{IL}	●			2	mA

The ● denotes specifications which apply over the full operating temperature range.

Note 1: $\pm 0.5LSB = \pm 0.012\%$ of full scale.

Note 2: Using internal feedback resistor.

Note 3: Guaranteed by design, not subject to test.

Note 4: I_{OUT1} with DAC register loaded with all 0s or I_{OUT2} with DAC register loaded with all 1s.

Note 5: Typical temperature coefficient is 100ppm/°C.

Note 6: OUT 1 load = 100 Ω in parallel with 13pF.

Note 7: To 0.01% for a full-scale change, measured from falling edge of $\overline{LD1}$ or $\overline{LD2}$.

Note 8: $V_{REF} = 0V$. DAC register contents changed from all 0s to all 1s or from all 1s to all 0s.

Note 9: $V_{REF} = 6V_{RMS}$ at 1kHz. DAC register loaded with all 1s.

Note 10: Calculation from $e_n = \sqrt{4KTRB}$ where: K = Boltzmann constant (J/K°); R = resistance (Ω); T = resistor temperature (°K); B = bandwidth (Hz).

Note 11: Minimum high time for STB1, STB2, STB4. Minimum low time for STB3.

Note 12: Minimum low time for STB1, STB2, STB4. Minimum high time for STB3.

BLOCK DIAGRAM

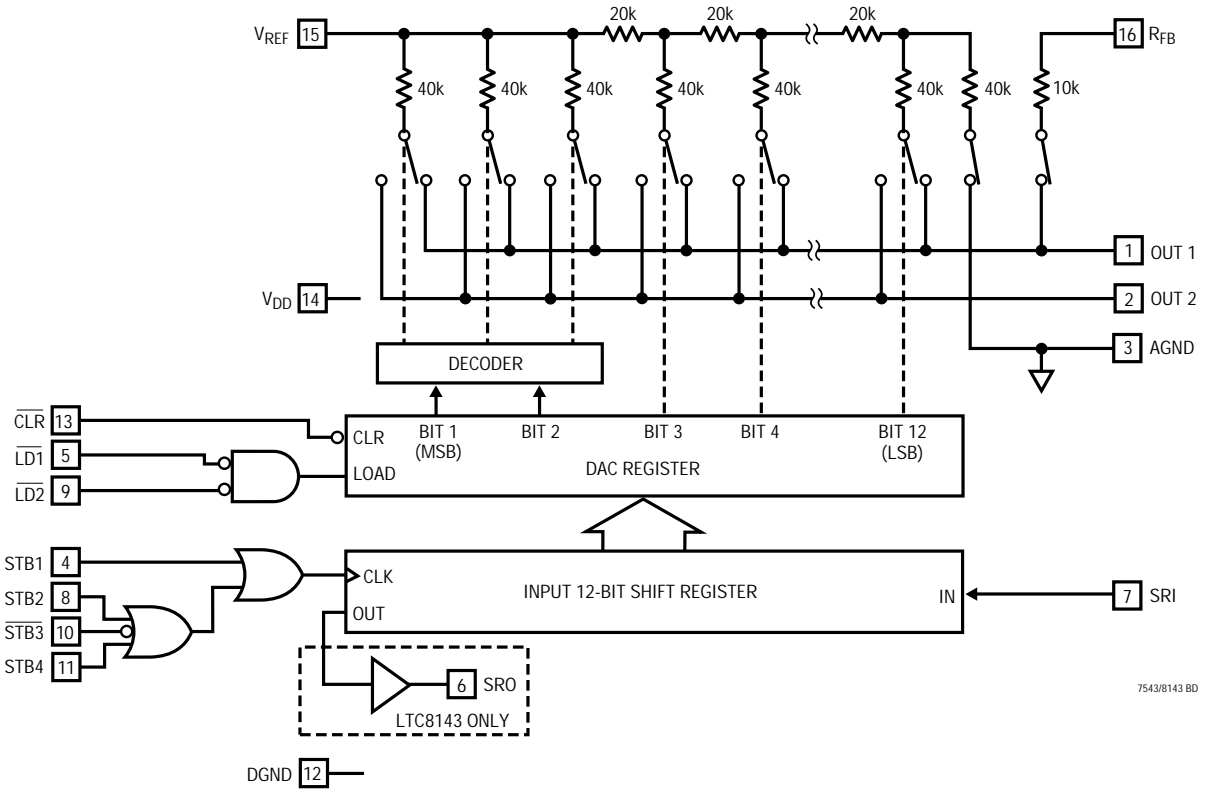

7543/8143 BD

TIMING DIAGRAM

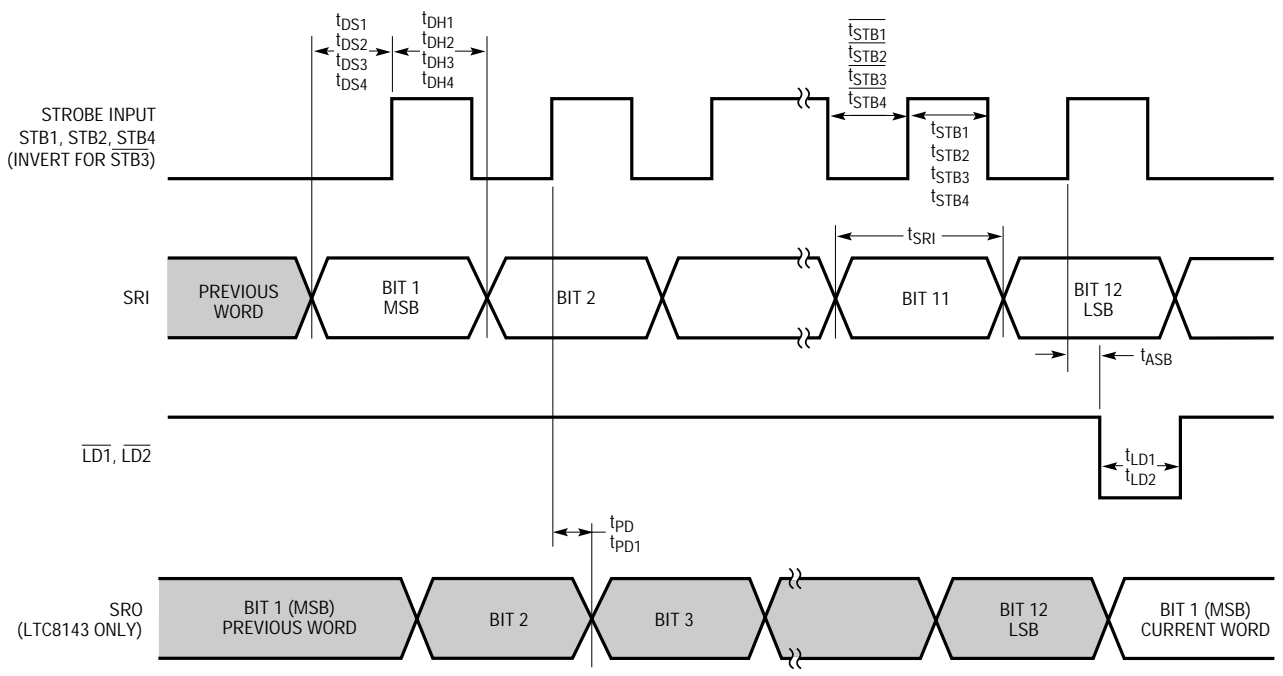

7543/8143 TD01

TRUTH TABLES

Table 1. LTC7543/LTC8143 Input Register

CONTROL INPUTS				Input Register Operation (LTC8143: SRO Operation)
STB1	STB2	STB3	STB4	
$\overline{1}$	0	1	0	Serial Data Bit on SRI Loaded into Input Register, MSB First (LTC8143: Data Bit or SRI Appears on SRO Pin After 12 Clocked Bits)
0	$\overline{1}$	1	0	
0	0	$\overline{1}$	0	
0	0	1	$\overline{1}$	
1	X	X	X	No Input Register Operation (LTC8143: No SRO Operation)
X	1	X	X	
X	X	0	X	
X	X	X	1	

Table 2. LTC7543/LTC8143 DAC Register

CONTROL INPUTS			DAC Register Operation
CLR	LD1	LD2	
0	X	X	Reset DAC Register to All 0s (Asynchronous Operation; No Effect on Input Register)
1	1	X	No DAC Register Operation
1	X	1	
1	0	0	Load DAC Register with the Contents of Input Register

TYPICAL APPLICATIONS

Unipolar Operation (2-Quadrant Multiplication)

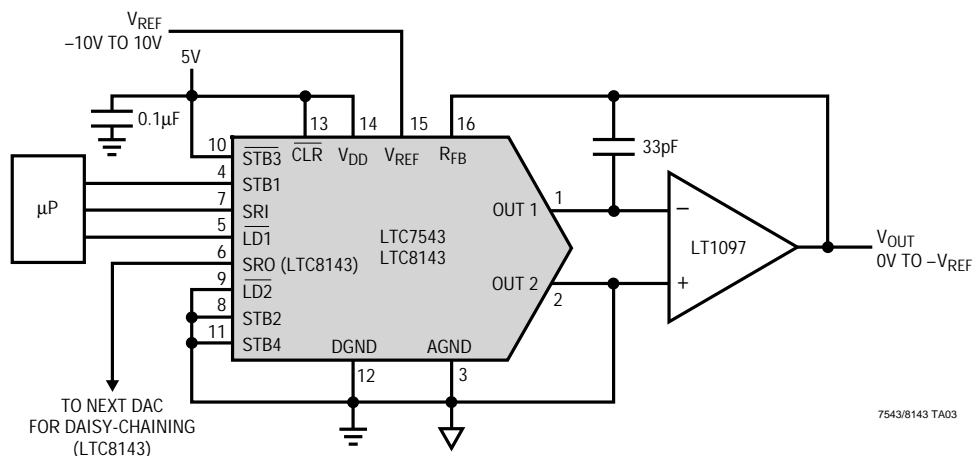

Unipolar Binary Code Table

DIGITAL INPUT BINARY NUMBER IN DAC REGISTER			ANALOG OUTPUT V_{OUT}
MSB		LSB	
1111	1111	1111	$-V_{REF}$ (4095/4096)
1000	0000	0000	$-V_{REF}$ (2048/4096) = $-V_{REF}/2$
0000	0000	0001	$-V_{REF}$ (1/4096)
0000	0000	0000	0V

TYPICAL APPLICATIONS

Bipolar Operation (4-Quadrant Multiplication)

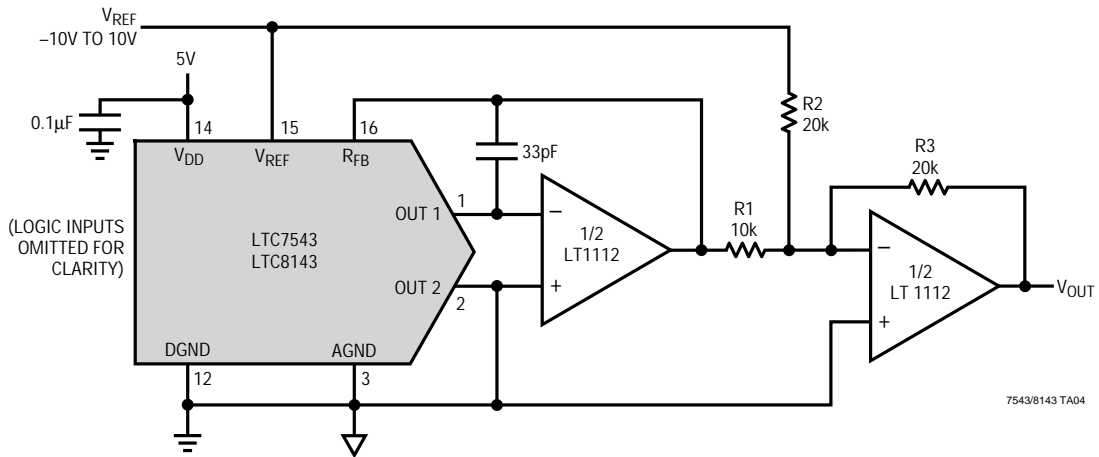

Bipolar Offset Binary Code Table

DIGITAL INPUT BINARY NUMBER IN DAC REGISTER			ANALOG OUTPUT V_{OUT}
MSB		LSB	
1111	1111	1111	V_{REF} (2047/2048)
1000	0000	0001	V_{REF} (1/2048)
1000	0000	0000	0V
0111	1111	1111	$-V_{REF}$ (1/2048)
0000	0000	0000	$-V_{REF}$ (2048/2048) = $-V_{REF}$

RELATED PARTS

PART NUMBER	DESCRIPTION	COMMENTS
LTC1257	Complete Serial I/O V_{OUT} 12-Bit DAC	5V to 15V Single Supply in 8-Pin SO and PDIP
LTC1451/LTC1452/LTC1453	Complete Serial I/O V_{OUT} 12-Bit DACs	3V/5V Single Supply in 8-Pin SO and PDIP
LTC7541A	Parallel I/O Multiplying 12-Bit DAC	12-Bit Wide Input
LTC8043	Serial Multiplying 12-Bit DAC	8-Pin SO and PDIP