

Op Amp Input Impedance

VOLTAGE FEEDBACK (VFB) OP AMP INPUT IMPEDANCE

Voltage feedback (VFB) op amps normally have both differential and common-mode input impedances specified. Current feedback (CFB) op amps normally specify the impedance to ground at each input. Different models may be used for different voltage feedback op amps, but in the absence of other information, it is usually safe to use the model in Figure 1 below. In this model the bias currents flow into the inputs from infinite impedance current sources.

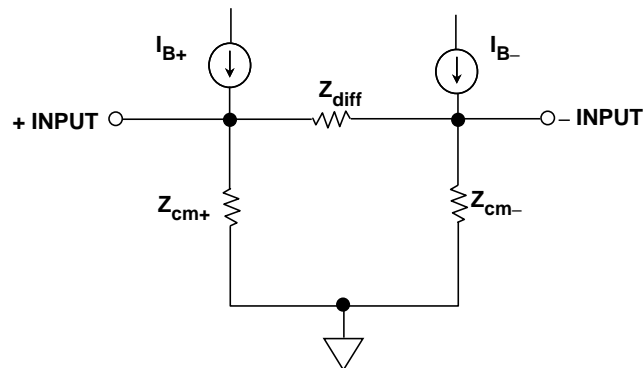

- ◆ Z_{cm+} and Z_{cm-} are the common-mode input impedance. The figure on the data sheet is for one, not both, but they are approximately equal. Z_{diff} is the differential input impedance.
- ◆ They are high resistance ($10^5 - 10^{12}\Omega$) in parallel with a small shunt capacitance (sometimes as high as 25pF).
- ◆ In most practical circuits, Z_{cm-} is swamped by negative feedback.

Figure 1: Input Impedance (Voltage Feedback Op Amp)

The common-mode input impedance data sheet specification (Z_{cm+} and Z_{cm-}) is the impedance from either input to ground (NOT from both to ground). The differential input impedance (Z_{diff}) is the impedance between the two inputs. These impedances are usually resistive and high ($10^5 - 10^{12}\Omega$) with some shunt capacitance (generally a few pF, but sometimes as high as 20-25 pF). In most op amp circuits, the inverting input impedance is reduced to a very low value by negative feedback, and only Z_{cm+} and Z_{diff} are of importance.

CURRENT FEEDBACK (CFB) OP AMP INPUT IMPEDANCE

A current feedback op amp is even more simple, as shown in Figure 2. The non-inverting input impedance, Z_+ , is resistive, generally with some shunt capacitance, and high (10^5 - $10^9 \Omega$) while Z_- is reactive (L or C, depending on the device) but has a resistive component of 10-100 Ω , varying from type to type.

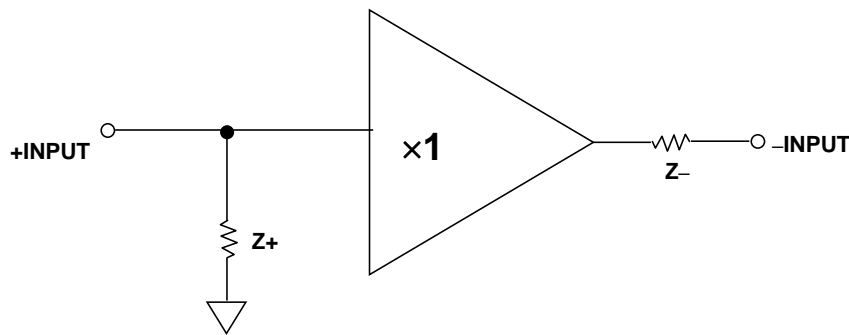

- ◆ Z_+ is high resistance ($10^5 - 10^9 \Omega$) with little shunt capacitance.
- ◆ Z_- is low and may be reactive (L or C). The resistive component is 10-100 Ω .

Figure 2: Input Impedance (Current Feedback Op Amp)

OP AMP INPUT CAPACITANCE

In many applications, the input capacitance of an op amp is not a problem. However where the source impedance is high, such as in a photodiode preamp, the diode capacitance adds to the op amp input capacitance and may require the addition of a feedback capacitor to stabilize the op amp. For high impedance high frequency sources, the input capacitance of the op amp should be significantly less than the source capacitance.

There is a second-order effect due to input capacitance of FET op amps, especially when used in the non-inverting mode. The input common-mode voltage modulates the capacitance and can cause distortion. To minimize this effect, make sure the source impedance (resistive and capacitive components) seen by each op amp input terminal is equal.

External stray capacitance on the inverting input of an op amp should be avoided, especially in high speed applications. The ground plane should be removed from the area directly surrounding the inverting input to minimize stray PC board capacitance, and all connections to this pin should be short. As mentioned above, the inverting input capacitance forms an additional pole in the op amp frequency response, and a feedback capacitor must be added for stabilization. The feedback capacitor also reduces the overall closed-loop bandwidth.

In the inverting mode, current feedback op amps are somewhat less sensitive to stray capacitance because the inverting input impedance is low to begin with. In the non-inverting mode, however, stray capacitance on the inverting input of a CFB op amp can cause instability and should be avoided.

REFERENCES:

1. Hank Zumbahlen, *Basic Linear Design*, Analog Devices, 2006, ISBN: 0-915550-28-1. Also available as [*Linear Circuit Design Handbook*](#), Elsevier-Newnes, 2008, ISBN-10: 0750687037, ISBN-13: 978-0750687034. Chapter 1.
2. Walter G. Jung, [*Op Amp Applications*](#), Analog Devices, 2002, ISBN 0-916550-26-5, Also available as [*Op Amp Applications Handbook*](#), Elsevier/Newnes, 2005, ISBN 0-7506-7844-5. Chapter 1.

Copyright 2009, Analog Devices, Inc. All rights reserved. Analog Devices assumes no responsibility for customer product design or the use or application of customers' products or for any infringements of patents or rights of others which may result from Analog Devices assistance. All trademarks and logos are property of their respective holders. Information furnished by Analog Devices applications and development tools engineers is believed to be accurate and reliable, however no responsibility is assumed by Analog Devices regarding technical accuracy and topicality of the content provided in Analog Devices Tutorials.