

LT8640SA
 42V, 6A Synchronous Step-Down Silent Switcher 2

General Description

The demonstration circuit EVAL-LT8640SA-AZ is a 42V, 6A micropower synchronous step-down second generation Silent Switcher® with spread spectrum frequency modulation featuring the LT8640SA. The demo board is designed for 5V output from a 5.8V to 42V input. The wide input range allows a variety of input sources, such as automotive batteries and industrial supplies. The LT8640SA is a compact, ultra-low emission, high efficiency, and high speed synchronous monolithic step-down switching regulator. The integrated bypass capacitors optimize all the fast current loops and make it easier to minimize EMI/EMC emissions by reducing layout sensitivity. Selectable spread spectrum mode can further improve EMI/EMC performance. Ultra-low quiescent current in Burst Mode® operation achieves high efficiency at very light loads. Fast minimum on-time of 30ns enables high V_{IN} to low V_{OUT} conversion at high frequency.

Program the LT8640SA switching frequency either through the oscillator resistor or external clock over a 200kHz to 3MHz range. The default frequency of demo circuit EVAL-LT8640SA-AZ is 2MHz. The SYNC pin on the demo board is grounded (JP1 at BURST position) by default for low ripple Burst Mode operation. To synchronize to an external clock, move JP1 to SYNC and apply the external clock to the SYNC terminal. Select the spread

spectrum mode and forced continuous mode (FCM) respectively by moving JP1 shunt. [Figure 3](#) shows the efficiency of the circuit at 12V input and 24V input in Burst Mode Operation. [Figure 4](#) shows the LT8640SA temperature rising on the EVAL-LT8640SA-AZ demo board under different load conditions. The rated maximum load current is 6A, while derating is necessary for certain input voltage and thermal conditions.

The demo board doesn't have an EMI filter installed, but it leaves footprints for the filter components. [Figure 5](#) shows the EMI performance of the board (without EMI filter). The red line in Radiated EMI Performance is the CISPR32 Class B limit. The figure shows that the circuit passes the test with a wide margin. An inductor and input capacitors can be added in the EMI filter footprint to further reduce the EMI emission.

The LT8640SA data sheet gives a complete description of the part, operation and application information. Read the data sheet in conjunction with this demo manual for EVAL-LT8640SA-AZ. The LT8640SA is assembled in a 4mm x 4mm LQFN package with exposed pads for low thermal resistance. The layout recommendations for low EMI operation and maximum thermal performance are available in the data sheet section 'Low EMI PCB Layout and Thermal Considerations and Peak Output Current'.

Performance Summary

Specifications are at $T_A = 25^\circ\text{C}$

PARAMETER	SYMBOL	CONDITIONS	MIN	TYP	MAX	UNIT
Input Supply Range	V_{IN}		5.8		42	V
Output Voltage	V_{OUT}		4.85	5	5.15	V
Maximum Output Current	I_{OUT}		6			A
Switching Frequency	f_{SW}	Derating is Necessary for Certain V_{IN} and Thermal Conditions	1.85	2	2.15	MHz
Efficiency	EFF	$V_{IN} = 12\text{V}, I_{OUT} = 3\text{A}$	94.3			%

Quick Start Procedure

The demonstration circuit EVAL-LT8640SA-AZ is easy to set up to evaluate the performance of LT8640SA. See [Figure 1](#) for proper measurement equipment setup and follow the procedures below:

NOTE: When measuring the input or output voltage ripple, be careful to avoid a long ground lead on the oscilloscope probe. See [Figure 2](#) for the proper scope technique.

1. Place JP1 on the BURST position.
2. With power off, connect the input power supply to V_{IN} and GND.
3. With power off, connect the load from V_{OUT} to GND.
4. Turn on the power supply at the input.
NOTE: Make sure that the input voltage does not exceed 42V.
5. Check for the proper output voltage ($V_{OUT} = 5V$).
NOTE: If there is no output, temporarily disconnect the load to make sure that the load is not set too high or is shorted.
6. Once the proper output voltage is established, adjust the load within the operating ranges and observe the output voltage regulation, ripple voltage, efficiency, and other parameters.
7. Add an external clock to the SYNC terminal when using the SYNC function (JP1 on the SYNC position). Choose the R2 to set the LT8640SA switching frequency equal to or below the lowest SYNC frequency. JP1 can also set LT8640SA in spread spectrum mode (JP1 on the SPREAD-SPECTRUM position) or forced continuous mode (JP1 on the FCM position).

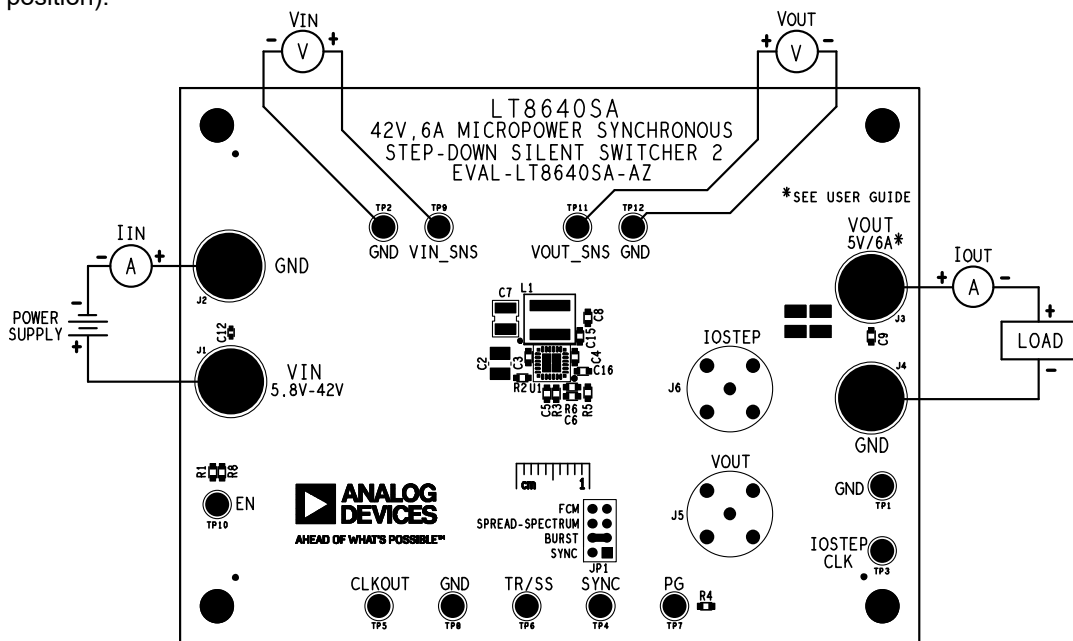

Figure 1. Proper Measurement Setup

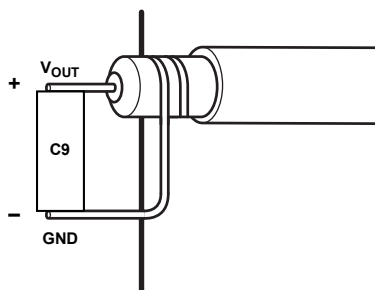

Figure 2. Scope Placement for Measuring Input or Output Voltage Ripple

Typical Performance Characteristics

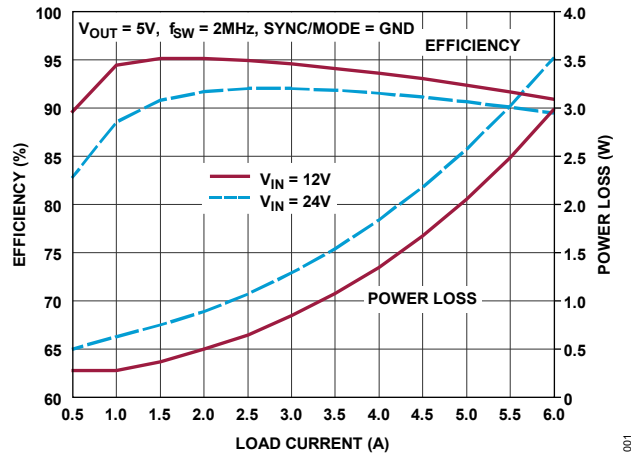

Figure 3. EVAL-LT8640SA-AZ Efficiency vs Load Current

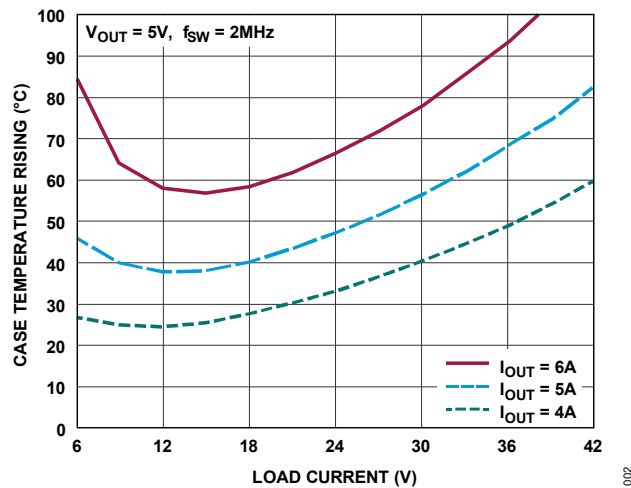

Figure 4. EVAL-LT8640SA-AZ Temperature Rising vs Input Voltage

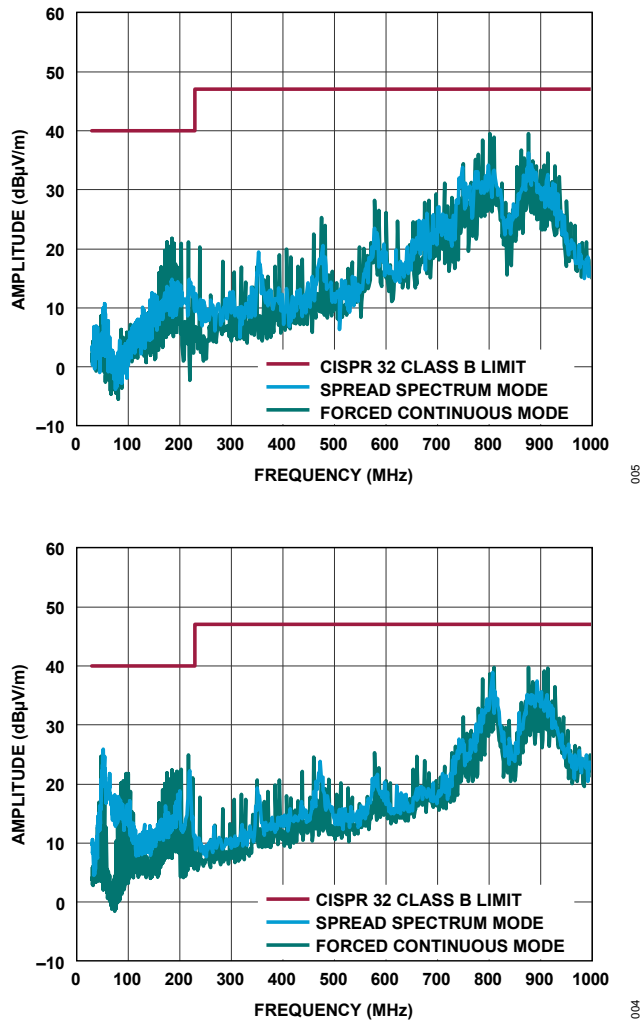
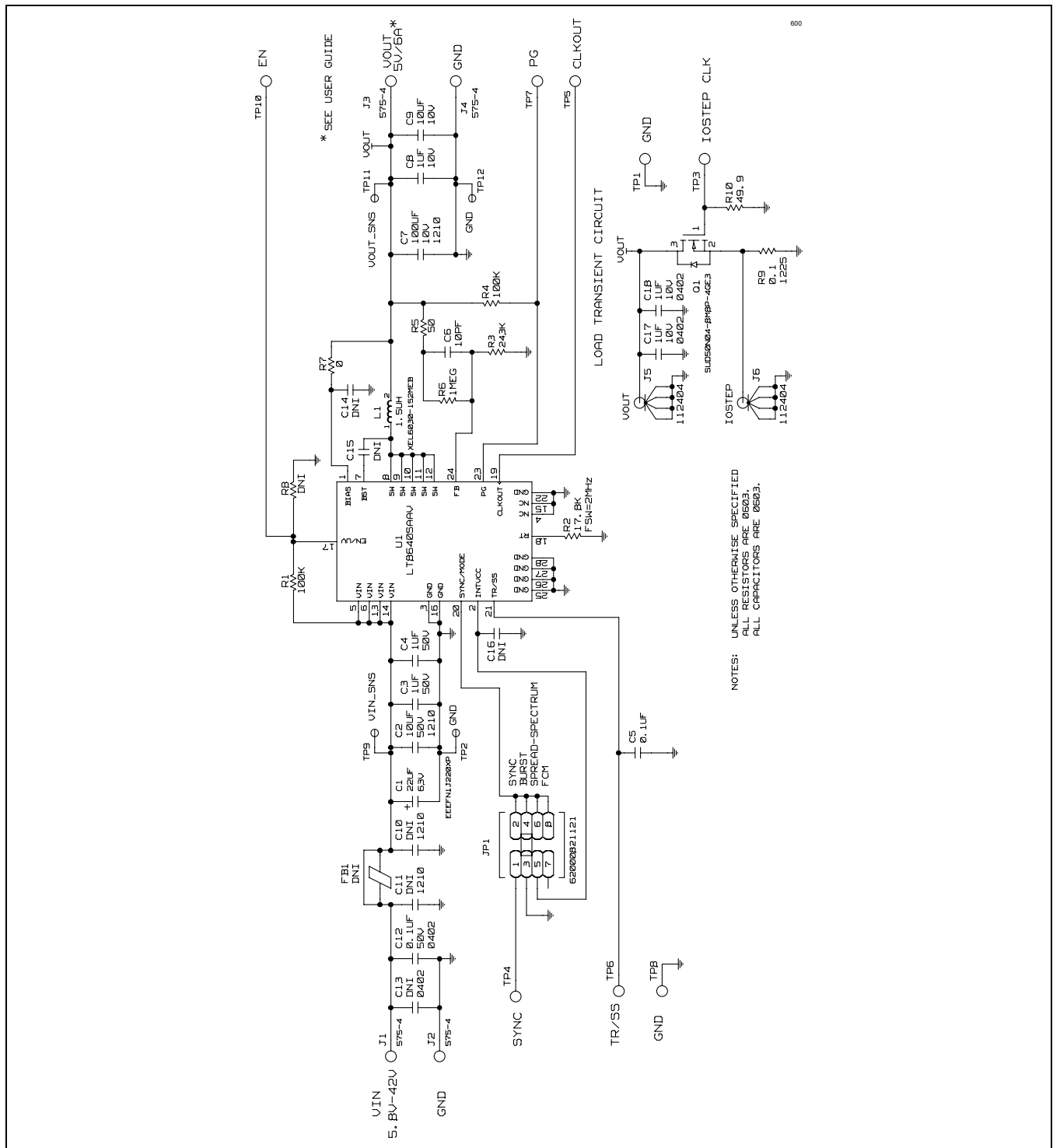

Figure 5. EVAL-LT8640SA-AZ CISPR 32 EMI Performance (14V Input, without EMI Filter, $I_{OUT} = 4A$)

EVAL-LT8640SA-AZ Kit Schematic



EVAL-LT8640SA-AZ Kit Bill of Materials

ITEM	QTY	REFERENCE	PART DESCRIPTION	MANUFACTURER/PART NUMBER
REQUIRED CIRCUIT COMPONENTS				
1	1	C1	CAP., ALUM ELECT 22 μ F, 63V, 20%, 6.3mm x 7.7mm, AEC-Q200, 1.2 Ω , 120MA, 2000H	EEEFN1J220XP
2	1	C12	CAP., CER 0.1 μ F, 50V, 10%, X7R 0402m, AEC-Q200, LOW ESR	CGA2B3X7R1H104K050BB
3	2	C17, C18	CAP., CER 1 μ F, 10V, 10%, X7S 0402	C1005X7S1A105K050BC
4	1	C2	CAP., CER 10 μ F, 50V, 10%, X7R 1210, AEC-Q200	12105C106K4T2A
5	2	C3, C4	CAP., CER 1 μ F, 50V, 10%, X5R 0603, AEC-Q200	GRT188R61H105KE13D
6	1	C5	CAP., CER 0.1 μ F, 16V, 10%, X7R 0603	C0603C104K4RAC
7	1	C6	CAP., CER 10pF, 50V, 5%, C0G 0603	C0603H100J5GAC7867
8	1	C7	CAP., CER 100 μ F, 10V, 20%, X5R 1210	GRM32ER61A107ME20L
9	1	C8	CAP., CER 1 μ F, 10V, 10%, X7R 0603	C0603C105K8RACTU
10	1	C9	CAP., CER 10 μ F, 10V, 10%, X5R 0603, LOW ESR	C1608X5R1A106K080AC
11	1	L1	IND POWER SHIELDED WIREWOUND 1.5 μ H, 20%, 1MHZ, 14A, 0.01052 Ω , DCR HIGH CURRENT, AEC-Q200	XEL6030-152MEB
12	1	Q1	TRAN N-CH MOSFET, 40V, 14A	SUD50N04-8M8P-4GE3
13	2	R1, R4	RES., SMD 100K Ω , 1%, 1/10W, 0603, AEC-Q200	CRCW0603100KFKEA
14	1	R10	RES., SMD 49.9 Ω , 1%, 1/10W, 0603, AEC-Q200	ERJ-3EKF49R9V
15	1	R2	RES., SMD 17.8K Ω , 1%, 1/10W, 0603, AEC-Q200	CRCW060317K8FKEA
16	1	R3	RES., SMD 243K Ω , 1%, 1/10W, 0603, AEC-Q200	CRCW0603243KFKEA
17	1	R5	RES., SMD 50 Ω , 1%, 1/10W, 0603, AEC-Q200	CRCW060350R0FKEA
18	1	R6	RES., SMD 1M Ω , 1%, 1/10W, 0603, AEC-Q200	CRCW06031M00FKEA
19	1	R7	RES., SMD 0 Ω , JUMPER, 1/10W 0603, AEC-Q200	ERJ-3GEY0R00V
20	1	R9	RES., SMD 0.1 Ω , 1%, 3W, 1225 WIDE, AEC-Q200	KRL6432E-C-R100-F-T1
21	1	U1	IC-ADI LT8640SA	LT8640SAAV#TRPBF
ADDITIONAL EVALUATION BOARD CIRCUIT COMPONENTS				
22	2	C10, C11	CAP CER, 10 μ F, 50V, 10%, X7R 1210	GRM32ER71H106KA12L
23	1	C13	CAP CER, 0.1 μ F, 50V, 10%, X7R 0402, AEC-Q200 LOW ESR	CGA2B3X7R1H104K050BB
24	3	C14, C15, C16	TBD0603	
25	1	FB1	IND FERRITE BEAD MULTI LAYER 100 Ω AT 100MHZ, 25%, 8A, 0.006 Ω , 1812, AEC-Q200	74279226101
26	1	R8	TBD0603	
HARDWARE: FOR EVALUATION BOARD ONLY				
27	1		SHUNT FEMALE 2POS 2mm	60800213421
28	4		STANDOFF, SELF-RETAINING SPACER, 12.7mm LENGTH	702935000
29	12	TP1, TP2, TP3, TP4, TP5, TP6, TP7, TP8, TP9, TP10, TP11, TP12	CONN-PCB SOLDER TERMINAL TEST POINT TURRET 0.094" MTG, HOLE PCB 0.062 INCH THK	2501-2-00-80-00-00-07-0
30	4	J1, J2, J3, J4	CONN-PCB, BANANA JACK, FEMALE, NON-INSULATED, THT, SWAGE, 0.218 INCHES LENGTH	575-4
31	2	J5, J6	CONN-PCB BNC JACK ST 50 Ω	112404
32	1	JP1	CONN-PCB 8POS MALE HDR UNSHROUDED DUAL ROW ST, 2mm PITCH, 2.80mm SOLDER TAIL	62000821121

EVAL-LT8640SA-AZ Kit PCB Layout

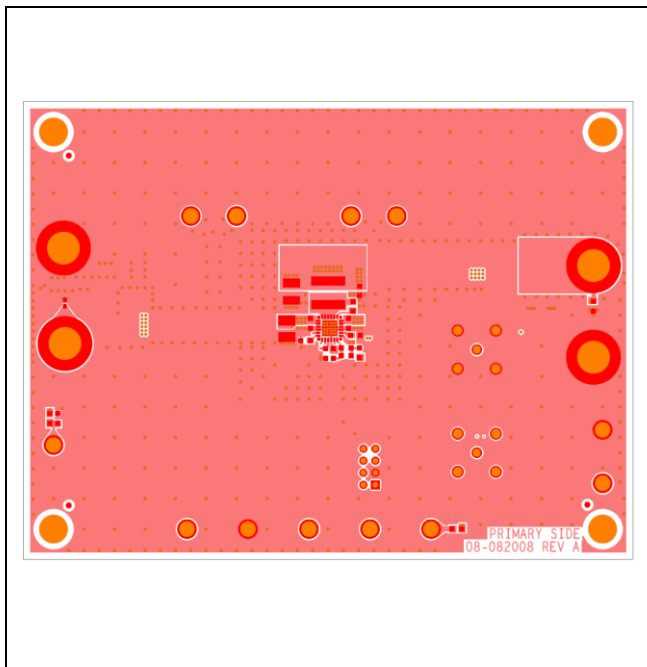

LT8640SA EV Kit PCB Layout—Layer 1

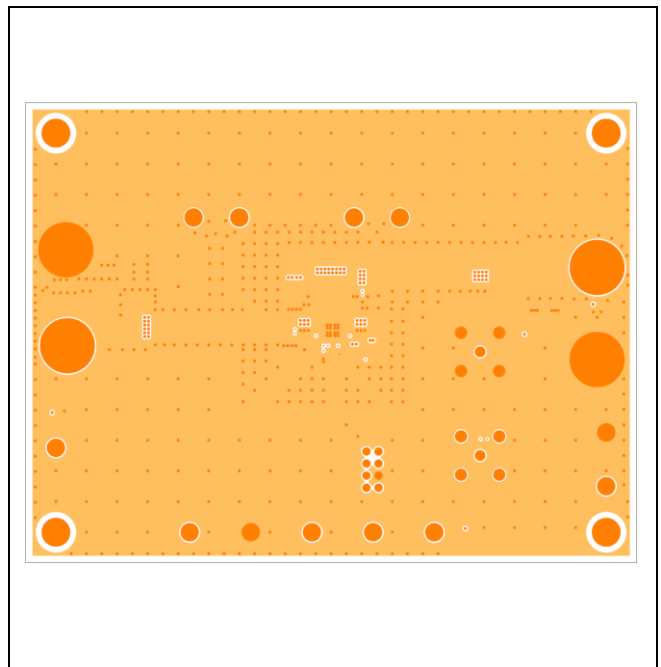

LT8640SA EV Kit PCB Layout—Layer 2

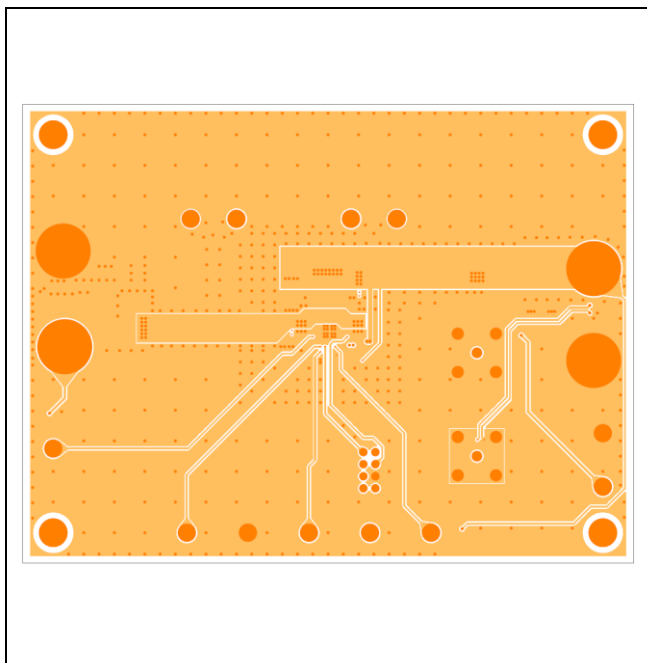

LT8640SA EV Kit PCB Layout—Layer 3

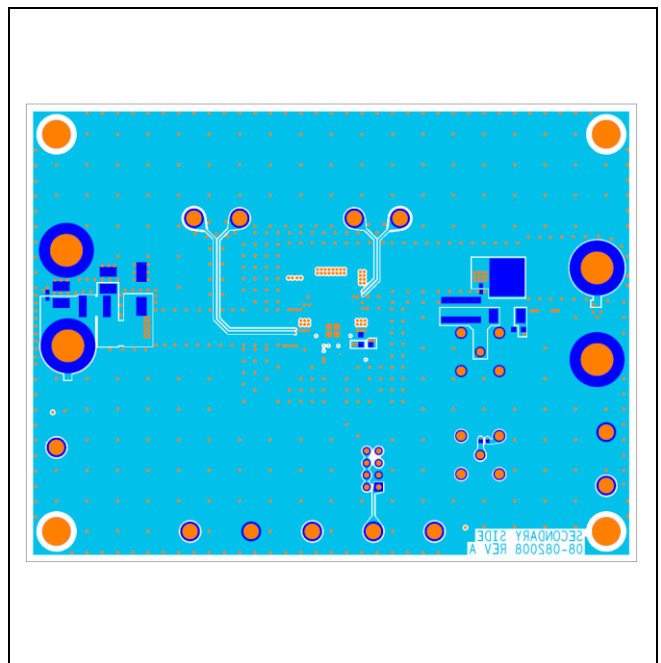

LT8640SA EV Kit PCB Layout—Bottom

EVAL-LT8640SA-AZ Kit PCB Layout (continued)

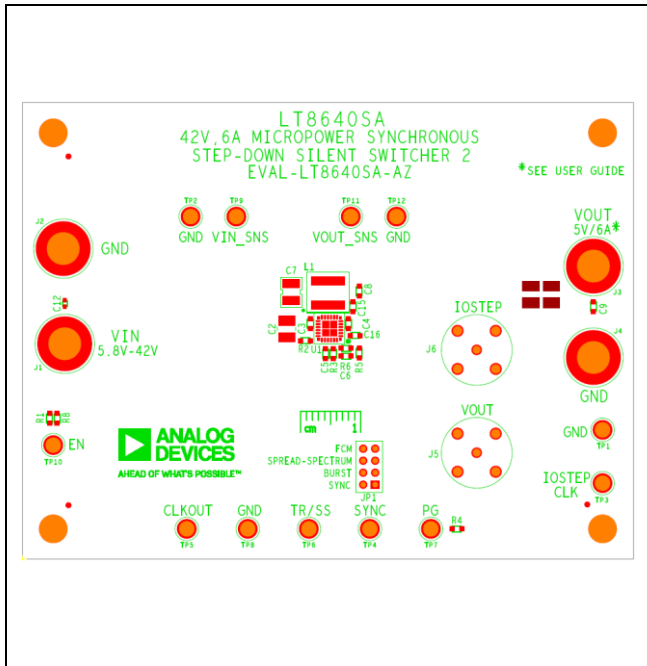

LT8640SA EV Kit Component Placement Guide—Top Silkscreen

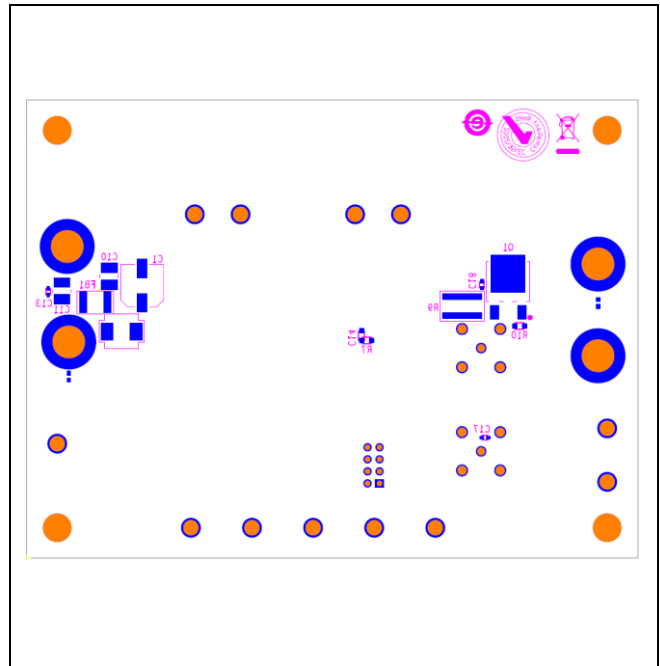

LT8640SA EV Kit Component Placement Guide—Bottom Silkscreen

Revision History

REVISION NUMBER	REVISION DATE	DESCRIPTION	PAGES CHANGED
0	09/24	Initial release	—

Notes

ALL INFORMATION CONTAINED HEREIN IS PROVIDED “AS IS” WITHOUT REPRESENTATION OR WARRANTY. NO RESPONSIBILITY IS ASSUMED BY ANALOG DEVICES FOR ITS USE, NOR FOR ANY INFRINGEMENTS OF PATENTS OR OTHER RIGHTS OF THIRD PARTIES THAT MAY RESULT FROM ITS USE. SPECIFICATIONS ARE SUBJECT TO CHANGE WITHOUT NOTICE. NO LICENSE, EITHER EXPRESSED OR IMPLIED, IS GRANTED UNDER ANY ADI PATENT RIGHT, COPYRIGHT, MASK WORK RIGHT, OR ANY OTHER ADI INTELLECTUAL PROPERTY RIGHT RELATING TO ANY COMBINATION, MACHINE, OR PROCESS, IN WHICH ADI PRODUCTS OR SERVICES ARE USED. TRADEMARKS AND REGISTERED TRADEMARKS ARE THE PROPERTY OF THEIR RESPECTIVE OWNERS. ALL ANALOG DEVICES PRODUCTS CONTAINED HEREIN ARE SUBJECT TO RELEASE AND AVAILABILITY.