

## 135V Buck Controller with Dynamically Adjustable Output Voltage

### General Description

The evaluation circuit EVAL-LT7809-AZ features the [LT®7809](#): a 135V synchronous buck controller with symmetrical sink/source capability and dynamically adjustable output voltage programming. The symmetrical sink and source current capability allow for fast  $V_{OUT}$  slewing up and down. Split gate drivers allow for easily adjustable turn-on and turn-off of FETs. Additionally, the IC features low  $I_Q$ , up to 2.5MHz programmable/synchronizable switching frequency, and a small 32-lead (5mm x 5mm) QFN package. These features allow for a wide variety of applications including industrial, military, medical, and telecommunications systems.

The EVAL-LT7809-AZ operates from a 16V to 100V input voltage range and generates a 60V, 5A output. Using the VOUTADJ feature, the output voltage can be lowered from

60V down to 4V without skipping cycles. The EVAL-LT7809-AZ is set to a 500kHz switching frequency, which results in a small and efficient circuit.

The EVAL-LT7809-AZ supports output voltages from 0.8V to 100V. The evaluation circuit has been designed with 150V FETs. Various FETs of similar footprint can be substituted to fit a wide array of applications.

The EVAL-LT7809-AZ is a high-performance, flexible step-down regulator that can adjust its output voltage on-the-fly. The LT7809 data sheet gives a complete description of this part, its operation, and application information. The data sheet must be read in conjunction with this user guide for the EVAL-LT7809-AZ.

**Design files for this circuit board are available at [www.analog.com](http://www.analog.com).**

### Performance Summary ( $T_A = 25^\circ\text{C}$ )

PARAMETER		CONDITIONS	MIN	TYP	MAX	UNITS
Input Voltage Range	$V_{IN}$	Non-Destructive	0		135	V
		Operating Range	16		100	
Output Voltage	$V_{OUT}$	100% Duty Cycle $16V \leq V_{IN} \leq V_{OUT(REG)}$ , $I_{ADJ} = 0\mu\text{A}$		$V_{IN}$		V
	$V_{OUT(REG)}$	Regulation $V_{OUT(REG)} < V_{IN} \leq 100V$ , $I_{ADJ} = 0\mu\text{A}$	58.7	60.8	62.9	
Load Current	$I_{OUT}$	$V_{OUT(REG)} < V_{IN} \leq 100V$ , $I_{ADJ} = 0\mu\text{A}$ No Airflow Maximum Board Temperature $< 100^\circ\text{C}$			5	A
Output Voltage Ripple		$V_{IN} = 100V$ , $I_{OUT} = 5A$		124		mV <sub>p-p</sub>
Run Rising Threshold				15.4		V
Run Falling Threshold				13.9		V
Switching Frequency	$f_{SW}$	JP1 = FIXED		500		kHz
Typical Efficiency	$V_{IN} = 100V$ , $V_{OUT} = 60V$ , $I_{OUT} = 5A$			97		%
	$V_{IN} = 48V$ , $V_{OUT} = 12V$ , $I_{OUT} = 5A$			93		%

## Quick Start Procedure

The evaluation circuit EVAL-LT7809-AZ is easy to set up to evaluate the performance of the LT7809. For a proper measurement equipment setup, see [Figure 1](#) and follow the procedure below.

1. Set the input power supply to a voltage between 16V and 100V. Disable the power supply output.  
**Note:** Make sure that the input voltage  $V_{IN}$  does not exceed 135V.
2. Connect the positive terminal of the power supply to  $V_{IN}$  and the negative terminal to GND.
3. Connect the load (< 5A) between  $V_{OUT}$  and GND.
4. Verify that the RUN switch (SW3) is set to the ON position and the INT POWER switch (SW2) is set to the OFF position.
5. Enable the input power supply and ramp the input voltage to 100V.
6. Verify that the output voltage is 60V using the voltmeter connected to  $V_{OUT}$ . If there is no output, temporarily disconnect the load to make sure that the load is not set too high.
7. Once the proper output voltage is established, adjust the load and observe the output voltage regulation, ripple voltage, efficiency, and other parameters.  
**Note:** When measuring the input or output voltage ripple, care must be taken to minimize the length of the oscilloscope probe's ground lead. Measure the input or output voltage ripple by connecting the probe tip directly across the  $V_{IN}$  or  $V_{OUT}$  and GND terminals. Preferably across the input or output capacitors.
8. The EVAL-LT7809-AZ can adjust its output voltage on-the-fly. Use the following jumper/switch settings:
  - a. SW2 (INT POWER) = ON
  - b. JP7 (PULSE POLARITY) = NORM
  - c. JP4 (VOUTADJ SOURCE) = INT
  - d. JP5 (VOUTADJ CURRENT) = 50 $\mu$ A
9. Set your oscilloscope to trigger when  $V_{OUT}$  falls below 55V. Press SW1 (PULSE).  $V_{OUT}$  will slew from 60V to 30V to 60V in 300 $\mu$ s. The waveform should resemble [Figure 8](#).

The EVAL-LT7809-AZ is a fully assembled and tested board that demonstrates the performance of the LT7809. The evaluation circuit is designed to deliver a 60V/5A output that can be adjusted on-the-fly.

## Adjusting the Output Voltage

The LT7809 can dynamically adjust its output voltage using its VOUTADJ pin. Current sunk into the VOUTADJ pin becomes an internal pull-up current on the  $V_{FB}$  pin, which lowers output voltage. The EVAL-LT7809-AZ features an adjustable 100 $\mu$ A current source that is connected to VOUTADJ pin. To enable this current source, turn SW2 (INT POWER) to the ON position. See [Table 3](#) to [Table 6](#) for details on how configure the VOUTADJ current source.

## Setting the Switching Frequency

Selecting the switching frequency is a trade-off between efficiency and component size. For optimal performance, a switching frequency of 500kHz is chosen for a wide output voltage range and a wide input voltage range. R13 programs the desired switching frequency. The switching frequency is set using the FREQ and PLLIN pins. Refer to the Setting the Operating Frequency section in the LT7809 data sheet for details.

## RUN Control (RUN, SW3)

The RUN turret of the evaluation circuit receives an external on/off signal for the controller. The EVAL-LT7809-AZ includes a resistive voltage divider (R6 and R47) connected between the  $V_{IN}$  and GND pins to turn on the device at the required input voltage. Turn the switch (SW3) to the ON position to connect the RUN pin to the center of this resistor divider. The EVAL-LT7809-AZ is designed to turn on the LT7809 around 15.4V. This threshold can be easily adjusted by changing R6 and R47. Turn SW3 to the OFF position to disable the controller. See [Table 7](#) to configure SW3.

### Track and Soft-Start Input (TRACK/SS Pin)

The LT7809's TRACK/SS pin can be used to program an external soft-start function, or to allow  $V_{OUT}$  to track another supply during startup. The adjustable soft-start function is used to limit the inrush current during startup. The soft-start time is adjusted by C4. An external supply can be connected to the TRACK/SS turret to make the startup of the  $V_{OUT}$  track an external supply. Typically, this requires connecting to the TRACK/SS turret through an external resistor divider from the external supply to GND. Refer to the Soft-Start and Tracking section on the data sheet.

### Mode Selection (MODE, JP2)

The EVAL-LT7809-AZ provides a jumper (JP2) to allow the LT7809 to operate in either forced continuous or pulse-skipping mode at lighter loads. Refer to the LT7809 data sheet for more details on the modes of operation. [Table 2](#) shows the mode selection JP2 settings that can be used to configure the desired mode of operation.

### Phase-Locked Loop, and External Frequency Synchronization (PLLIN, JP1)

The LT7809 features a phase-locked loop to synchronize the internal oscillator to an external clock source. The EVAL-LT7809-AZ provides a SYNC turret to connect an external clock source to synchronize with the device switching. Keep the jumper (JP1) in the EXT position when the external clock signal is applied. For more details about external clock synchronization, refer to the LT7809 data sheet.

### EXTV<sub>CC</sub> Linear Regulator

The EXTV<sub>CC</sub> pin allows DRV<sub>CC</sub> to be derived from a high efficiency external source (up to 30V max). On EVAL-LT7809-AZ, the EXTV<sub>CC</sub> pin is connected to the included high efficiency LTC3639 step-down regulator, which provides a 12V rail.

### Thermal Performance

The EVAL-LT7809-AZ features excellent thermal performance due to the high efficiency of the synchronous step-down controller circuitry. The component temperatures of EVAL-LT7809-AZ with a typical 100V input, 60V output, and 5A load are shown in [Figure 7](#). The six-layer PCB layout features solid copper planes that provide adequate heat spreading across the whole board.

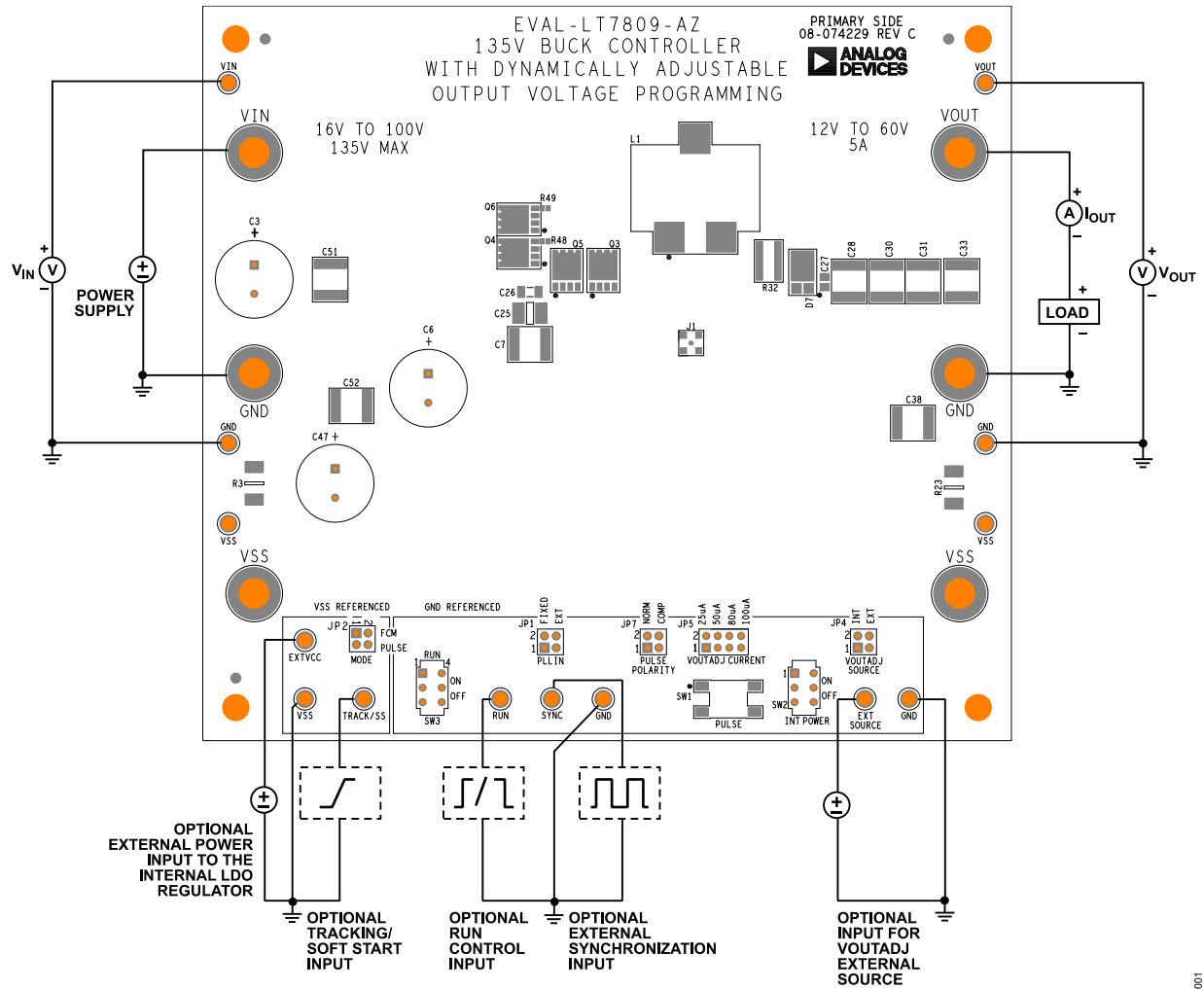

Figure 1. EVAL-LT7809-AZ Board Connections

001

Table 1. PLLIN Selection Jumper (JP1) Settings

SHUNT POSITION	PLLIN PIN	DESCRIPTION
1-2*	Connected to GND	Fixed frequency
3-4	Connected to SYNC Turret	External clock synchronization

\*Default position

Table 2. MODE Jumper (JP2) Settings

SHUNT POSITION	MODE PIN	LIGHT-LOAD OPERATION
1-2*	Connected to INTV <sub>CC</sub>	Forced continuous mode
3-4	Connected to INTV <sub>CC</sub> with a 100kΩ	Pulse-skipping mode

\*Default position

**Table 3. VOUTADJ SOURCE (JP4) Settings**

SHUNT POSITION	VOUTADJ SOURCE	DESCRIPTION
1-2*	INT (Internal)	VOUTADJ current will be set by JP5 and triggered by SW1 (PULSE).
3-4	EXT (External)	VOUTADJ current will be set by supply on EXT SOURCE and GND turret.

\*Default position

**Table 4. VOUTADJ CURRENT (JP5) Settings**

SHUNT POSITION	VOUTADJ CURRENT	ADJUSTED VOUT
1-2*	25 $\mu$ A	45V
3-4	50 $\mu$ A	30V
5-6	80 $\mu$ A	12V
7-8	100 $\mu$ A	0V

\*Default position

**Table 5. PULSE POLARITY (JP7) Settings**

SHUNT POSITION	PULSE POLARITY	DESCRIPTION
1-2*	NORM (Normal)	Steps the VOUTADJ current set by JP5 when push button is pressed.
3-4	COMP (Complementary)	Enables VOUTADJ current set by JP5 and disables current source only when the push button is pressed.

\*Default position

**Table 6. INT POWER Switch (SW2) Settings**

SWITCH POSITION	INT POWER	DESCRIPTION
ON*	Connects $V_{IN}$ to generate the 5V and 10V rails (relative to ground) for VOUTADJ's current source.	Enables supply for VOUTADJ circuitry. Enables SW1 (PULSE).
OFF	Disables the 5V and 10V rails (relative to ground) for VOUTADJ's current source.	Disables supply for VOUTADJ circuitry. Disables SW1 (PULSE). $V_{OUT(REG)} \approx 60V$

\*Default position

**Table 7. RUN Switch (SW3) Settings**

SWITCH POSITION	RUN PIN	CONTROLLER
ON*	Connected to the center node of the resistor-divider R6 and R47.	Starts up at the desired input voltage level.
OFF	Connected to GND	Disabled

\*Default position

Performance

( $V_{IN} = 100V$ ,  $V_{OUT} = 60V$ ,  $I_{OUT} = 5A$ ,  $f_{SW} = 500kHz$ , MODE = FCM,  $T_A = +25^{\circ}C$ , unless otherwise noted.)

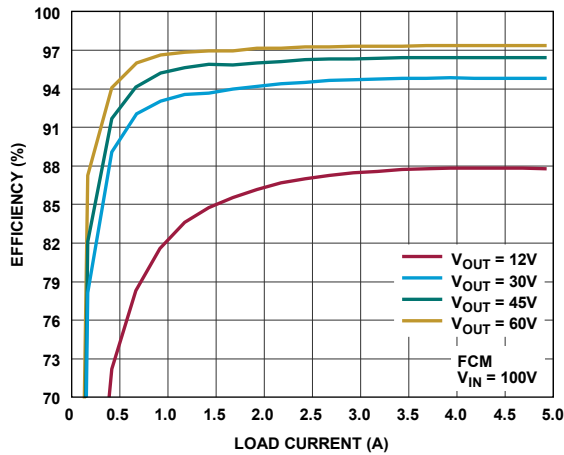

Figure 2. Efficiency vs Load Current  
Multiple  $V_{OUT}$  curves are plotted using the EVAL-LT7809-AZ's VOUTADJ feature.

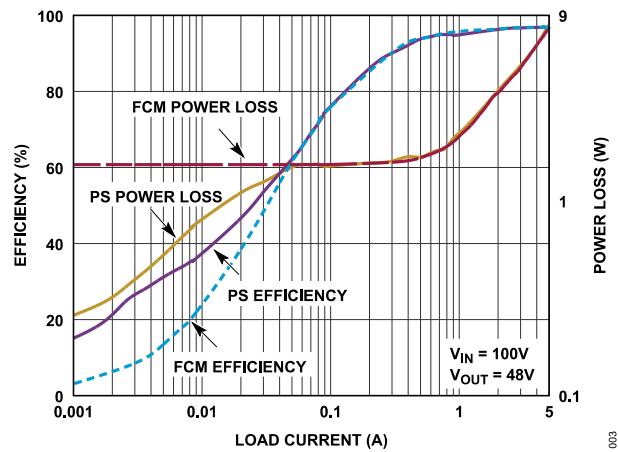

Figure 3. Efficiency and Power Loss vs Load Current  
Efficiency improves in pulse-skipping mode during light load.

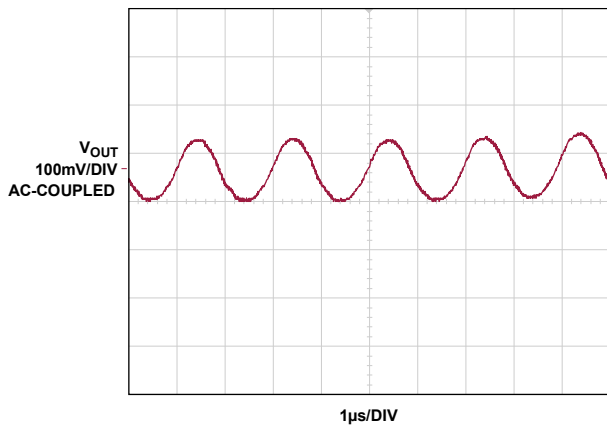

Figure 4. Output Voltage Ripple  
 $V_{IN} = 100V$ ,  $V_{OUT} = 60V$ , and  $I_{OUT} = 5A$ .

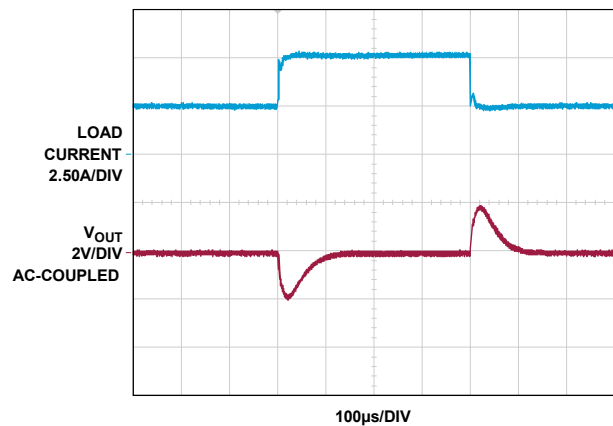

Figure 5. Load Step Response  
 $V_{IN} = 100V$  and  $V_{OUT} = 60V$ .

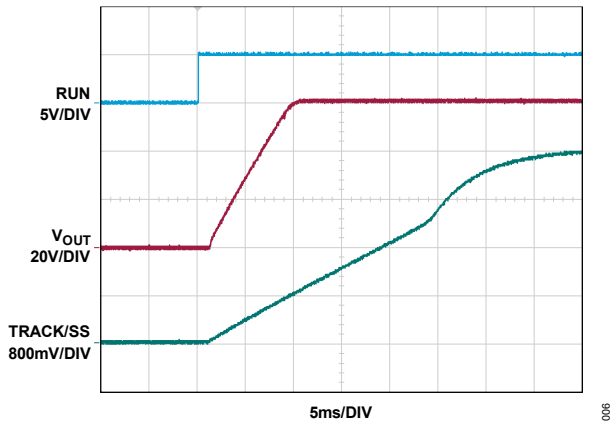

Figure 6. Soft-Start Behavior.  $V_{IN} = 100V$ . Output voltage ramps to 60V, following TRACK/SS up to 800mV.

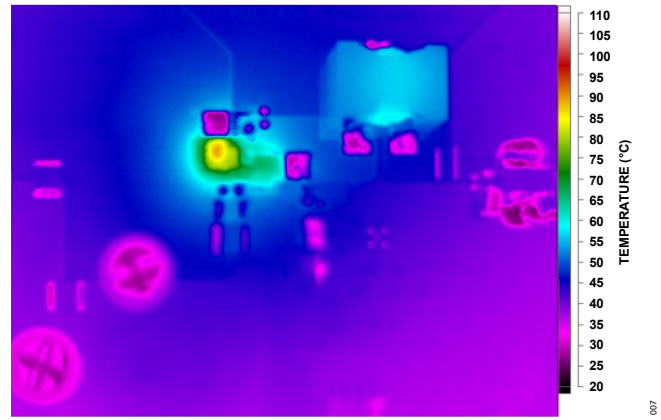

Figure 7. Thermal Performance.  $V_{IN} = 100V$ ,  $V_{OUT} = 60V$ ,  $I_{OUT} = 5A$ , No airflow. The hottest component on EVAL-LT7809-AZ stays under  $100^{\circ}C$  ( $T_A = 25^{\circ}C$ ).

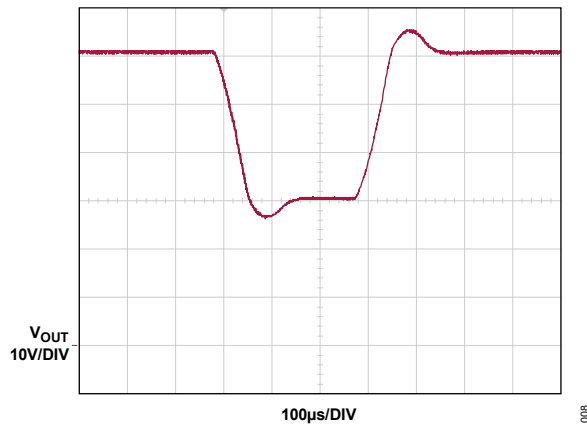
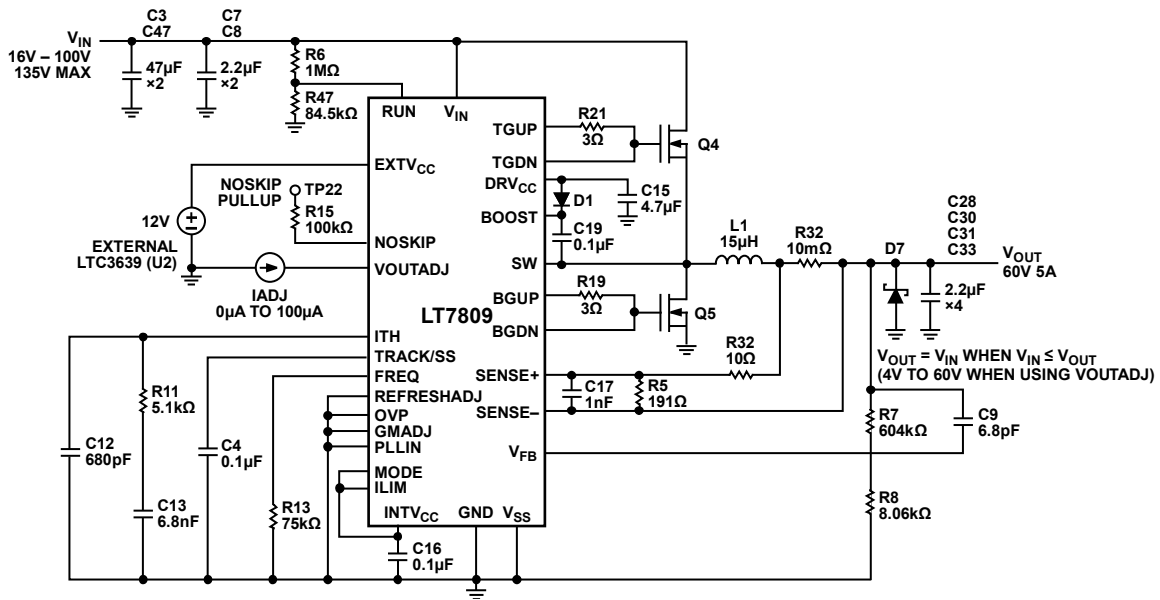

Figure 8. Dynamic  $V_{OUT}$  adjustment.  $V_{IN} = 100V$ . No Load. Using the VOUTADJ circuitry on the EVAL-LT7809-AZ,  $V_{OUT}$  steps from 60V to 30V by pulsing  $50\mu A$  into VOUTADJ.

Simplified Schematic



009

Detailed Schematic

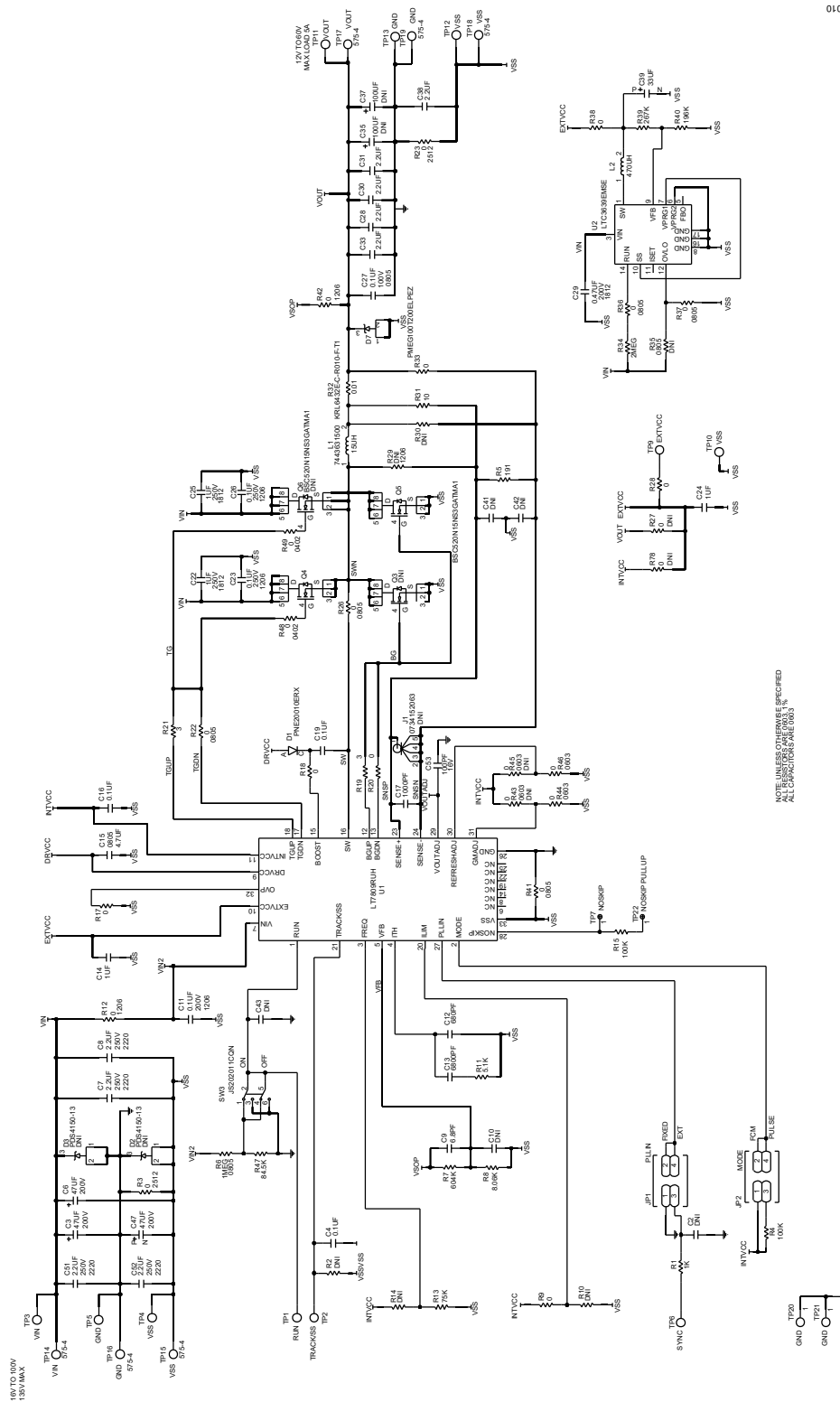

010



**Revision History**

<b>REVISION NUMBER</b>	<b>REVISION DATE</b>	<b>DESCRIPTION</b>	<b>PAGES CHANGED</b>
0	12/25	Initial release	—

## Notes

ALL INFORMATION CONTAINED HEREIN IS PROVIDED “AS IS” WITHOUT REPRESENTATION OR WARRANTY. NO RESPONSIBILITY IS ASSUMED BY ANALOG DEVICES FOR ITS USE, NOR FOR ANY INFRINGEMENTS OF PATENTS OR OTHER RIGHTS OF THIRD PARTIES THAT MAY RESULT FROM ITS USE. SPECIFICATIONS ARE SUBJECT TO CHANGE WITHOUT NOTICE. NO LICENSE, EITHER EXPRESSED OR IMPLIED, IS GRANTED UNDER ANY ADI PATENT RIGHT, COPYRIGHT, MASK WORK RIGHT, OR ANY OTHER ADI INTELLECTUAL PROPERTY RIGHT RELATING TO ANY COMBINATION, MACHINE, OR PROCESS, IN WHICH ADI PRODUCTS OR SERVICES ARE USED. TRADEMARKS AND REGISTERED TRADEMARKS ARE THE PROPERTY OF THEIR RESPECTIVE OWNERS. ALL ANALOG DEVICES PRODUCTS CONTAINED HEREIN ARE SUBJECT TO RELEASE AND AVAILABILITY.