

Evaluating the ADXL382 SPI, Low Noise, Low Power, Wide Bandwidth, 3-Axis MEMS Accelerometer

FEATURES

- ▶ Provides interface to host system through a 10-pin, dual-row, 2.00mm pitch header
- ▶ Small size and board stiffness minimizes impact on the system and acceleration measurements

EQUIPMENT NEEDED

- ▶ External host processor

DOCUMENTS NEEDED

- ▶ [ADXL382 data sheet](#)

EVALUATION BOARD PHOTOGRAPH

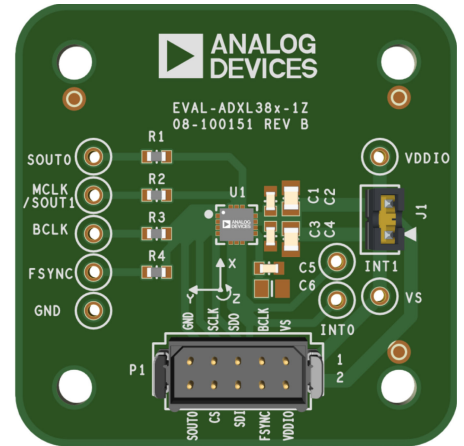

Figure 1. EVAL-ADXL382-1Z Evaluation Board Top View

GENERAL DESCRIPTION

The EVAL-ADXL382-1Z is a simple evaluation board that allows quick evaluation of the performance of the ADXL382 SPI, low noise, low power, wide bandwidth, 3-axis, digital output, microelectronic mechanical system (MEMS) accelerometer. The evaluation board provides a 10-pin header for access to the main ADXL382 communication signals.

TABLE OF CONTENTS

| | | | |
|----------------------------------|---|---------------------------------|---|
| Features..... | 1 | Circuit Description..... | 3 |
| Equipment Needed..... | 1 | Handling Considerations..... | 3 |
| Documents Needed..... | 1 | Evaluation Board Schematic..... | 4 |
| Evaluation Board Photograph..... | 1 | Ordering Information..... | 5 |
| General Description..... | 1 | Ordering Guide..... | 5 |
| Evaluation Board Hardware..... | 3 | Bill of Materials..... | 5 |

REVISION HISTORY**6/2026—Revision 0: Initial Version**

EVALUATION BOARD HARDWARE

The EVAL-ADXL382-1Z incorporates a 10-pin, dual-row, 2.00mm pitch header that provides access to the power supply and key signal lines. This connector enables connection of the evaluation board to an external host processor or interface board. Four holes are provided in the corners of the board for mechanical attachment of the EVAL-ADXL382-1Z to an application. An external host processor is required for communication with the [ADXL382](#).

The dimensions of the EVAL-ADXL382-1Z are 38mm × 38mm × 2mm. The center of each of the four mounting holes is located 5.08mm from the edges of the printed circuit board (PCB). Each hole has a diameter of 3.04mm and is sized for M3 screws (see [Figure 1](#)).

CIRCUIT DESCRIPTION

The PCB layout of the EVAL-ADXL382-1Z is shown in [Figure 1](#). The EVAL-ADXL382-1Z is equipped with five factory installed ceramic capacitors: C1 = C3 = C5 = 0.1μF and C2 = C4 = 1μF. C1 to C4 are optional capacitors meant for decoupling the accelerometer from the noise on the power supply. In contrast, C5 is required and ensures internal supply stability.

A jumper connects the V_S pin or the V_{DDIO} pin, enabling the board to be powered using one supply voltage applied to either of the two pins.

On the bottom side of the PCB, a set of check boxes is used to indicate the assembled device variant. The ADXL382 option is marked on this board (see [Figure 2](#)).

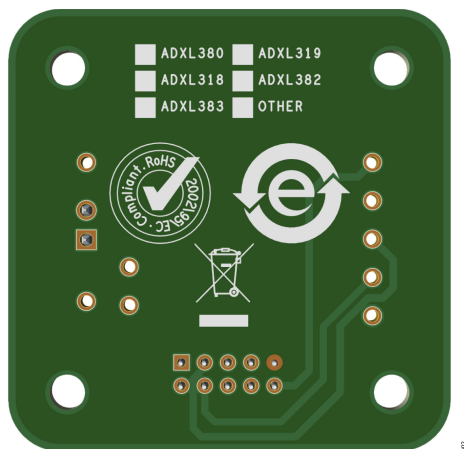

Figure 2. EVAL-ADXL382-1Z Evaluation Board Bottom View

The schematic of the EVAL-ADXL382-1Z is shown in [Figure 3](#).

Some components (test points and C6) are designated as do not install (DNI) and are not populated on this board (see [Table 2](#)). The INT0, INT1, and SOUT1/MCLK signals are accessible only via these test points and are not routed to the P1 connector.

Refer to the ADXL382 data sheet for information on configuring the accelerometer after connection to the application host processor.

HANDLING CONSIDERATIONS

The EVAL-ADXL382-1Z is not reverse polarity protected. Reversing the V_S or V_{DDIO} supply and GND pins can cause damage to the ADXL382.

Dropping the EVAL-ADXL382-1Z on a hard surface can generate several thousand g of acceleration, which may exceed the absolute maximum limits of the device. See the ADXL382 data sheet for additional information.

EVALUATION BOARD SCHEMATIC

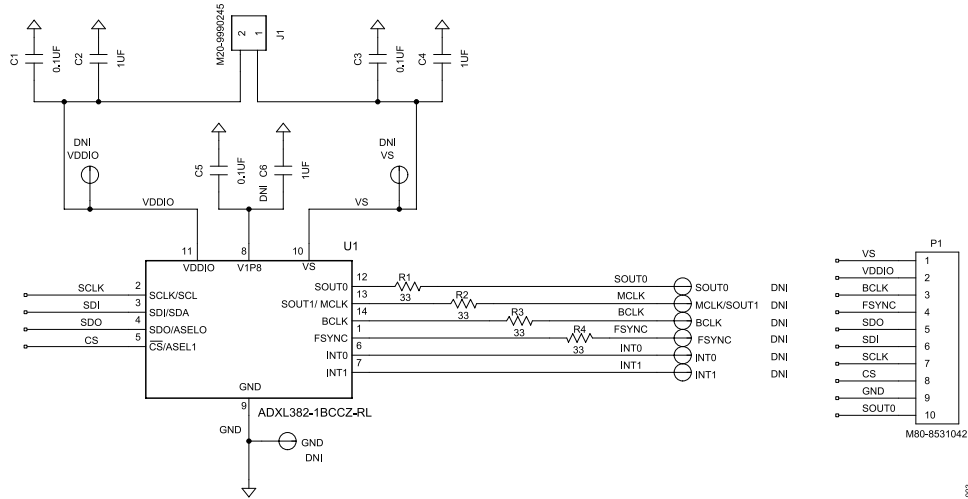

Figure 3. EVAL-ADXL382-1Z Evaluation Board Schematic

ORDERING INFORMATION

ORDERING GUIDE

| Model ¹ | Description |
|--------------------|------------------------------|
| EVAL-ADXL382-1Z | ADXL382 SPI Evaluation Board |

¹ Z = RoHS-Compliant Part.

BILL OF MATERIALS

Table 1. Bill of Materials

| Item | Quantity | Reference Designator | Description | Manufacturer | Part Number |
|------|----------|----------------------|--|----------------------|----------------------|
| 1 | 1 | U1 | SPI, low noise, low power, wide bandwidth, 3-Axis MEMS accelerometer | Analog Devices, Inc. | ADXL382-1BCCZ-RL |
| 2 | 3 | C1, C3, C5 | 0.1µF ceramic capacitors, 50V, 10%, X7R, 0603 | TDK | CGA3E2X7R1H104K080AE |
| 3 | 2 | C2, C4 | 1µF ceramic capacitors, 25V, 10%, X7R, 0805 | TDK | CGA4J3X7R1E105K125AB |
| 4 | 1 | J1 | 2-position header, throughhole, 2.54mm pitch | Harwin | M20-9990245 |
| 5 | 1 | P1 | 10-position, dual-row header, throughhole, 2.00mm pitch | Harwin | M80-8531042 |
| 6 | 4 | R1, R2, R3, R4 | 33Ω resistors, ±5%, 0.1W, 0603 | Panasonic Industry | ERJ-3GEYJ330V |

Table 2. Do Not Install (DNI) Components

| Item | Quantity | Reference Designator | Description | Manufacturer | Part Number |
|------|----------|--|--|----------------------|----------------------|
| 1 | 9 | BCLK, FSYNC, GND, INT0, INT1, SOUT0, SOUT1/MCLK, VDDIO, VS | PC test points, miniature black | Keystone Electronics | 5001 |
| 2 | 1 | C6 | 1µF ceramic capacitor, 25V, 10%, X7R, 0805 | TDK | CGA4J3X7R1E105K125AB |

**ESD Caution**

ESD (electrostatic discharge) sensitive device. Charged devices and circuit boards can discharge without detection. Although this product features patented or proprietary protection circuitry, damage may occur on devices subjected to high energy ESD. Therefore, proper ESD precautions should be taken to avoid performance degradation or loss of functionality.

Legal Terms and Conditions

By using the evaluation board discussed herein (together with any tools, components documentation or support materials, the "Evaluation Board"), you are agreeing to be bound by the terms and conditions set forth below ("Agreement") unless you have purchased the Evaluation Board, in which case the Analog Devices Standard Terms and Conditions of Sale shall govern. Do not use the Evaluation Board until you have read and agreed to the Agreement. Your use of the Evaluation Board shall signify your acceptance of the Agreement. This Agreement is made by and between you ("Customer") and Analog Devices, Inc. ("ADI"), with its principal place of business at One Analog Way, Wilmington, MA 01887-2356, U.S.A. Subject to the terms and conditions of the Agreement, ADI hereby grants to Customer a free, limited, personal, temporary, non-exclusive, non-sublicensable, non-transferable license to use the Evaluation Board FOR EVALUATION PURPOSES ONLY. Customer understands and agrees that the Evaluation Board is provided for the sole and exclusive purpose referenced above, and agrees not to use the Evaluation Board for any other purpose. Furthermore, the license granted is expressly made subject to the following additional limitations: Customer shall not (i) rent, lease, display, sell, transfer, assign, sublicense, or distribute the Evaluation Board; and (ii) permit any Third Party to access the Evaluation Board. As used herein, the term "Third Party" includes any entity other than ADI, Customer, their employees, affiliates and in-house consultants. The Evaluation Board is NOT sold to Customer; all rights not expressly granted herein, including ownership of the Evaluation Board, are reserved by ADI. CONFIDENTIALITY. This Agreement and the Evaluation Board shall all be considered the confidential and proprietary information of ADI. Customer may not disclose or transfer any portion of the Evaluation Board to any other party for any reason. Upon discontinuation of use of the Evaluation Board or termination of this Agreement, Customer agrees to promptly return the Evaluation Board to ADI. ADDITIONAL RESTRICTIONS. Customer may not disassemble, decompile or reverse engineer chips on the Evaluation Board. Customer shall inform ADI of any occurred damages or any modifications or alterations it makes to the Evaluation Board, including but not limited to soldering or any other activity that affects the material content of the Evaluation Board. Modifications to the Evaluation Board must comply with applicable law, including but not limited to the RoHS Directive. TERMINATION. ADI may terminate this Agreement at any time upon giving written notice to Customer. Customer agrees to return to ADI the Evaluation Board at that time. LIMITATION OF LIABILITY. THE EVALUATION BOARD PROVIDED HEREUNDER IS PROVIDED "AS IS" AND ADI MAKES NO WARRANTIES OR REPRESENTATIONS OF ANY KIND WITH RESPECT TO IT. ADI SPECIFICALLY DISCLAIMS ANY REPRESENTATIONS, ENDORSEMENTS, GUARANTEES, OR WARRANTIES, EXPRESS OR IMPLIED, RELATED TO THE EVALUATION BOARD INCLUDING, BUT NOT LIMITED TO, THE IMPLIED WARRANTY OF MERCHANTABILITY, TITLE, FITNESS FOR A PARTICULAR PURPOSE OR NON-INFRINGEMENT OF INTELLECTUAL PROPERTY RIGHTS. IN NO EVENT WILL ADI AND ITS LICENSORS BE LIABLE FOR ANY INCIDENTAL, SPECIAL, INDIRECT, OR CONSEQUENTIAL DAMAGES RESULTING FROM CUSTOMER'S POSSESSION OR USE OF THE EVALUATION BOARD, INCLUDING BUT NOT LIMITED TO LOST PROFITS, DELAY COSTS, LABOR COSTS OR LOSS OF GOODWILL. ADI'S TOTAL LIABILITY FROM ANY AND ALL CAUSES SHALL BE LIMITED TO THE AMOUNT OF ONE HUNDRED US DOLLARS (\$100.00). EXPORT. Customer agrees that it will not directly or indirectly export the Evaluation Board to another country, and that it will comply with all applicable United States federal laws and regulations relating to exports. GOVERNING LAW. This Agreement shall be governed by and construed in accordance with the substantive laws of the Commonwealth of Massachusetts (excluding conflict of law rules). Any legal action regarding this Agreement will be heard in the state or federal courts having jurisdiction in Suffolk County, Massachusetts, and Customer hereby submits to the personal jurisdiction and venue of such courts. The United Nations Convention on Contracts for the International Sale of Goods shall not apply to this Agreement and is expressly disclaimed. All Analog Devices products contained herein are subject to release and availability.

