

Evaluating the ADuM7801, 8-Lead SOIC 25MHz Isolated ADC with Sigma-Delta Modulated Bit Stream Output

FEATURES

- ▶ Simplified evaluation of the [ADuM7801](#) isolated ADC with Σ - Δ modulated bit stream output
- ▶ Footprint for 6mm × 10mm, 8-lead SOIC_IC package with >8.0mm creepage and clearance
- ▶ On-board power supplies
- ▶ On-board [ADuM6028-5](#) ISO DC-DC converter and [ADP7142](#) low noise CMOS LDO regulator with jumper options for simplified evaluation in multiple supply configurations
- ▶ SMA connectors for MDAT output signal, MCLK input, and V_{IN+} , V_{IN-} analog input signals
- ▶ Resistors and footprints for termination
- ▶ Test points for measuring all signals
- ▶ Standalone capability
- ▶ ZedBoard™ controller board compatible
- ▶ PC-based software for control and data analysis

EVALUATION KIT CONTENTS

- ▶ EV-ADuM7801-8FMCZ evaluation board

EQUIPMENT NEEDED

- ▶ Oscilloscope
- ▶ Signal generator
- ▶ Power supply
- ▶ ZedBoard Zynq-7000 development board (optional)
 - ▶ USB cable (provided in ZedBoard kit)
 - ▶ 24V wall wart signal source (provided in ZedBoard kit)
 - ▶ 16GB (or larger) Class 10 (or faster) micro-SD card
 - ▶ PC running Windows® Vista SP2 (32-bit or 64-bit), Windows 7 SP1 (32-bit or 64-bit), Windows 8.1 (32-bit or 64-bit), Windows 10 (32-bit or 64-bit), or Windows 11 (32-bit or 64-bit) with a USB 2.0 port

DOCUMENTS NEEDED

- ▶ ADuM7801 data sheet

SOFTWARE NEEDED

- ▶ If using ZedBoard Zynq-7000 as controller board:
 - ▶ [Analysis | Control | Evaluation \(ACE\) Software](#)
 - ▶ ADuM7801 ACE plug-in (provided in ACE Software)
 - ▶ [Kuijper Linux](#) page

GENERAL DESCRIPTION

The EV-ADuM7801-8FMCZ is a fully-featured evaluation board that allows the user to evaluate all features of the ADuM7801 isolated ADC with Σ - Δ modulated bit stream output. The ZedBoard Zynq-7000 controller board controls the EV-ADuM7801-8FMCZ by the J9 connector and through the USB port of a PC using the ACE Software. The ACE Software is available to download on the ACE Software page.

On-board components include an isolated, 5kV, *isoPower*® DC-to-DC converter (the ADuM6028-5), a 5V, low noise, low dropout (LDO) regulator (the [ADP7104](#)), and a 200mA, 40V, low noise, LDO regulator (the ADP7142).

This user guide explains how to use the EV-ADuM7801-8FMCZ to evaluate the ADuM7801. The ADuM7801 is a high-performance isolated analog-to-digital converter (ADC) with a second-order Σ - Δ modulator that converts an analog input signal into a high speed, single-bit data stream, with on-chip digital isolation based on Analog Devices, Inc., *iCoupler*® technology. The device operates from a 4.0V to 5.5V power supply range (high-side supply voltage, V_{DD1}) and accepts a pseudodifferential input signal of ± 250 mV (± 320 mV full-scale). The pseudodifferential input is ideally suited for shunt-resistor current monitoring in high voltage applications where galvanic isolation is required.

The analog input is continuously sampled by a high-performance analog modulator and converted to a pulse density modulation digital output stream with a data rate of up to 25MHz. The analog input can be reconstructed with an appropriate sinc3 digital filter to achieve an 88dB signal-to-noise ratio (SNR) at 97.6kSPS with a 256 decimation rate and a 25MHz input clock. The serial input and output operates from a 3V to a 5.5V supply (controller-side supply voltage, V_{DD2}).

The serial interface is digitally isolated. The on-chip isolation provides performance characteristics superior to alternatives, such as optocoupler devices, due to high speed CMOS technology combined with monolithic transformer technology. The ADuM7801 has an operating temperature range of -40°C to $+125^{\circ}\text{C}$.

Full specifications on the ADuM7801 are available in the ADuM7801 data sheet available from Analog Devices, Inc., and must be consulted with this user guide when using the EV-ADuM7801-8FMCZ evaluation board.

TABLE OF CONTENTS

Features.....	1	Evaluation Board Software.....	7
Evaluation Kit Contents.....	1	Software Installation Procedures.....	7
Equipment Needed.....	1	Evaluation Board Setup Procedures.....	10
Documents Needed.....	1	ACE Software Operation.....	11
Software Needed.....	1	Launching the Software.....	11
General Description.....	1	Chip View Window Features.....	12
Evaluation Board Connection Diagram.....	3	Waveform Tab.....	13
Evaluation Board Hardware.....	4	Histogram Tab.....	13
Power Supplies.....	4	FFT Tab.....	13
Input Signals.....	4	Exiting the Software.....	13
Link Configuration Options.....	5	Evaluation Board Schematic and Silkscreens.....	16
Sockets and Connectors.....	6	Bill of Materials.....	21
Test Points.....	6		

REVISION HISTORY**4/2026—Rev. 0 to Rev. A**

Changes to User Guide Title.....	1
Changed ADuM7801-8 to ADuM7801 (Throughout).....	1

4/2026—Revision 0: Initial Version

EVALUATION BOARD CONNECTION DIAGRAM

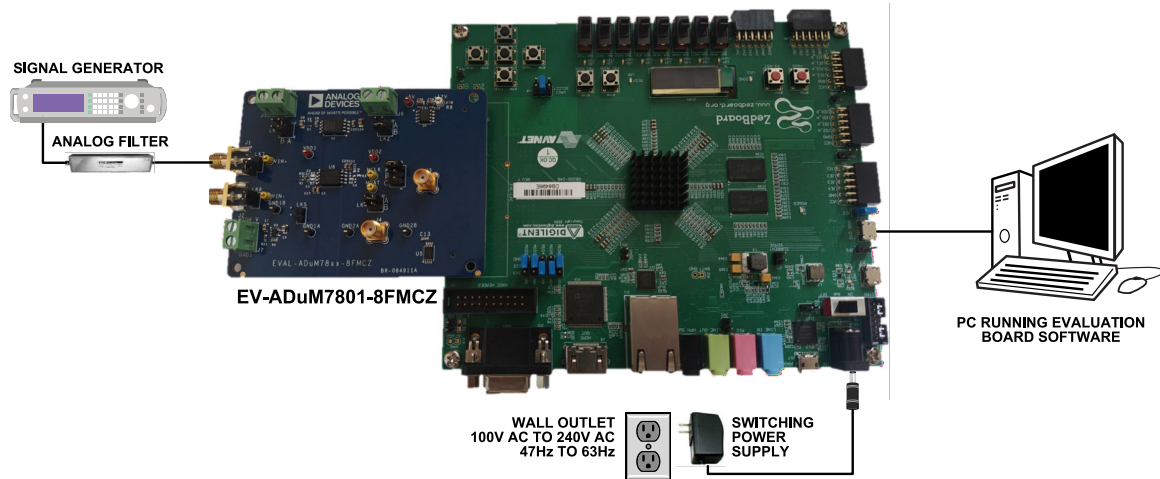

Figure 1. Evaluation Board and ZedBoard Connection Diagram

101

EVALUATION BOARD HARDWARE

POWER SUPPLIES

Ensure that all link positions are set according to the required operating mode before applying power and signals to the EV-ADuM7801-8FMCZ. For the list of link options, see [Table 2](#).

The EV-ADuM7801-8FMCZ is powered by the ZedBoard Zynq-7000. The ZedBoard generates 12V and 3.3V supply rails. The 12V supply is connected to the on-board [ADP7104ARDZ-5.0](#) that powers the [ADuM6028-5](#). The ADuM6028-5 generates an isolated 5V supply to power the V_{DD1} rail of the [ADuM7801](#). The 3.3V supply rail generated by the ZedBoard powers the V_{DD2} rail of the ADuM7801.

To power the V_{DD1} externally, connect an external power supply in the 5V to 40V range to the high voltage (HIGH_V) J7 connector, or connect an external power supply in the 4V to 5.5V range to the J5 connector.

To power the V_{DD2} externally, connect an external power supply in the 3V to 5.5V range to the J6 connector.

There are two main ground planes, GND_1 and GND_2 , on the EV-ADuM7801-8FMCZ. The GND_1 and GND_2 planes are isolated with a creepage and clearance of >8mm.

When an external voltage is supplied to the J6 input connector, and the EV-ADuM7801-8FMCZ is connected to the ZedBoard, ensure that the voltage does not exceed 3.3V. Exceeding 3.3V causes permanent damage to the ZedBoard.

INPUT SIGNALS

Note that do not exceed an analog input of $\pm 250mV$ ($\pm 320mV$ at full scale) to the ADuM7801. Connect an input signal of up to 500mV peak-to-peak to the EV-ADuM7801-8FMCZ by the J1 analog input connector.

The EV-ADuM7801-8FMCZ has analog and digital ground planes that are physically isolated from each other. Power to the analog supply rail is supplied through the on-board ADuM6028-5. V_{DD1} can be supplied from the J5 external connector or from the HIGH_V J7 external connector. The on-board [ADP7142](#) steps a 5V to 40V range supply connected to the J7 connector down to 5V. For more details on supplying V_{DD1} externally, see [Table 1](#) and [Table 2](#).

Table 1. External Power Supplies (Optional)

Power Supply	Connector	Voltage Range	Purpose
V_{DD1}	J5	4V to 5.5V	Analog supply rail.
V_{DD2}	J6	3V to 5.5V	Digital supply rail without the ZedBoard connected.
		3.15V to 3.45V	Digital supply rail with the ZedBoard connected.
HIGH_V	J7	5V to 40V	Analog supply rail (high voltage alternative to J5).

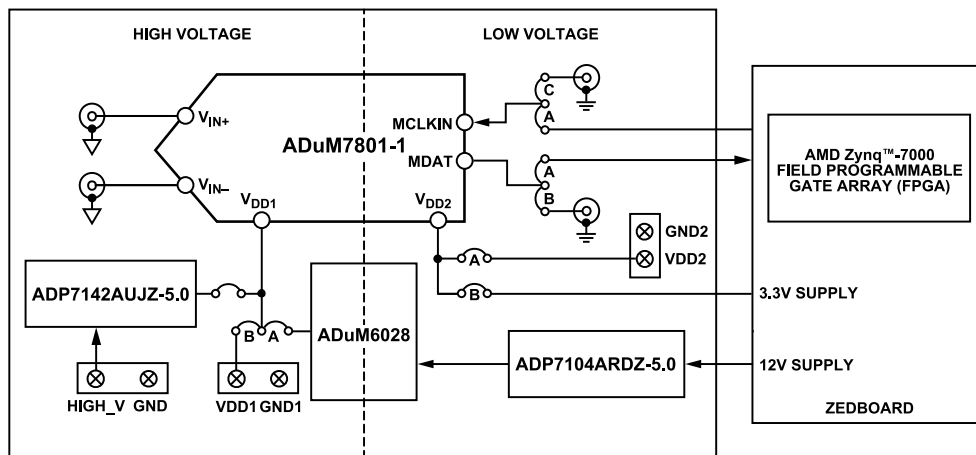

Figure 2. EV-ADuM7801-8FMCZ Block Diagram

EVALUATION BOARD HARDWARE

LINK CONFIGURATION OPTIONS

Multiple link options must be set properly to select the appropriate operating setup before using the EV-ADuM7801-8FMCZ. The functions of these link options are outlined in [Table 2](#).

Setup Conditions

Ensure that all link positions are set as required by the operating mode before applying power and signals to the EV-AD-

uM7801-8FMCZ. The EV-ADuM7801-8FMCZ operates in stand-alone mode or in ZedBoard controlled mode when used with the ZedBoard Zynq-7000.

[Table 2](#) shows the default positions of the links when the EV-ADuM7801-8FMCZ is packaged. When the EV-ADuM7801-8FMCZ is shipped, the evaluation board is set up to operate in ZedBoard controlled mode with power supplied from the ZedBoard development board. The on-board [ADuM6028-5](#) powers the V_{DD1} .

Table 2. Link Options

Category	Link	Default Position	Function
Power Supplies	LK1	A	LK1 selects the ADuM7801 V_{DD1} supply source. Remove LK5 if using Position A or Position B. In Position A, the on-board ADuM6028-5 supplies V_{DD1} . In Position B, the J5 connector supplies V_{DD1} externally.
	LK5	Removed	Insert LK5 to power V_{DD1} with the on-board ADP7142AUJZ-5.0 by the J7 connector. Remove LK5 if V_{DD1} is powered via LK1.
	LK2	B	LK2 selects the ADuM7801 V_{DD2} supply source. In Position A, the J6 connector supplies V_{DD2} externally. In Position B, the ZedBoard supplies V_{DD2} .
Analog Input	LK7	Removed	Insert LK7 to short V_{IN+} to ground. Remove LK7 if a signal is applied to V_{IN+} .
	LK8	Inserted	Insert LK8 to short V_{IN-} to ground. Remove LK8 if a signal is applied to V_{IN-} .
Serial Interface	LK3	A	LK3 selects the MCLKIN source for the serial interface. In Position A, the SDP-H1 sources MCLKIN. In Position B, do not use. In Position C, the J3 Subminiature Version A (SMA) connector sources MCLKIN (standalone mode).
	LK4	A	LK4 routes the MDAT output for the serial interface. In Position A, MDAT is sent to the ZedBoard. In Position B, MDAT is sent to the J4 SMA connector (standalone mode).

EVALUATION BOARD HARDWARE

SOCKETS AND CONNECTORS

Table 3 shows the connectors and sockets on the EV-ADuM7801-8FMCZ.

Table 3. On-Board Connectors

Connector	Function
J1	Analog input V_{IN+}
J2	Analog input V_{IN-}
J3	MCLK input (standalone mode)
J4	MDAT output (standalone mode)
J5	V_{DD1} external source
J6	V_{DD2} external source
J7	V_{DD1} external source (high voltage)

The default interface to the EV-ADuM7801-8FMCZ is achieved by the 160-way connector. The connector attaches the EV-ADuM7801-8FMCZ to the ZedBoard. When the EV-ADuM7801-8FMCZ is used in standalone mode, communication is achieved via the J3 SMA connector and the J4 SMA connector. For more details on configuring the EV-ADuM7801-8FMCZ for standalone mode, see Table 2.

TEST POINTS

There are several test points on the EV-ADuM7801-8FMCZ. These test points provide access to the EV-ADuM7801-8FMCZ signals for probing, evaluation, and debugging.

EVALUATION BOARD SOFTWARE

SOFTWARE INSTALLATION PROCEDURES

Download the [ACE Software](#) from the ACE Software page. Install the ACE Software before using the EV-ADuM7801-8FMCZ.

The ACE installation process in the [Installing the ACE Software](#) section includes the ACE Software installation and the ZedBoard driver installation.

Install the ACE Software and ZedBoard drivers before connecting the EV-ADuM7801-8FMCZ and the ZedBoard to the USB port of the PC to ensure that the evaluation system is properly recognized when it is connected to the PC.

Installing the ACE Software

To install the ACE Software, do the following steps:

1. Download the ACE Software to a Windows-based PC.
2. Double-click the **ACEInstall.exe** file to begin the installation. By default, the ACE Software is saved to the following location:
C:\Program Files (x86)\Analog Devices\ACE.
3. A dialog box appears asking for permission to allow the program to make changes to the PC. Click **Yes** to start the installation process.
4. In the **ACE Setup** window, click **Next >** to continue the installation (see [Figure 3](#)).

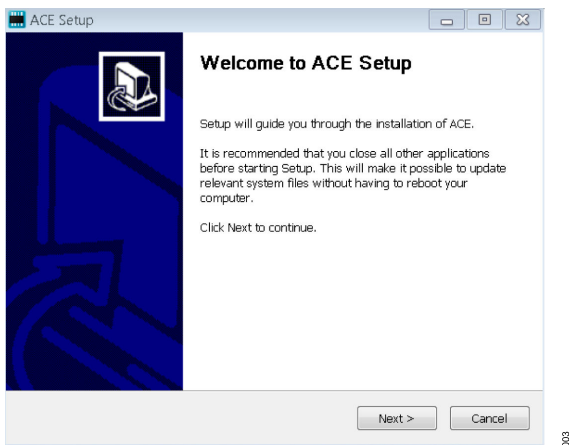

Figure 3. ACE Software Installation Confirmation

5. Read the Software License Agreement, and click **I Agree** (see [Figure 4](#)).

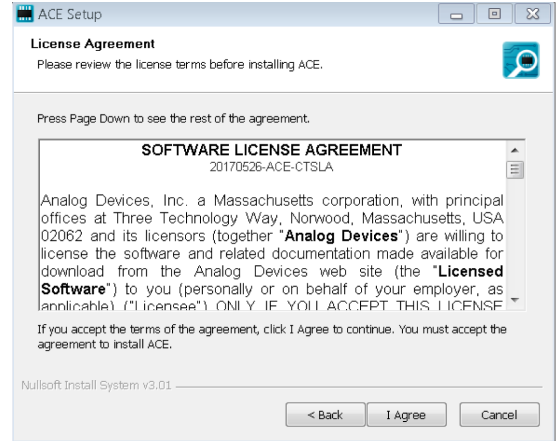

Figure 4. License Agreement

6. Click **Browse...** to choose the installation location, and then click **Next >** (see [Figure 5](#)).

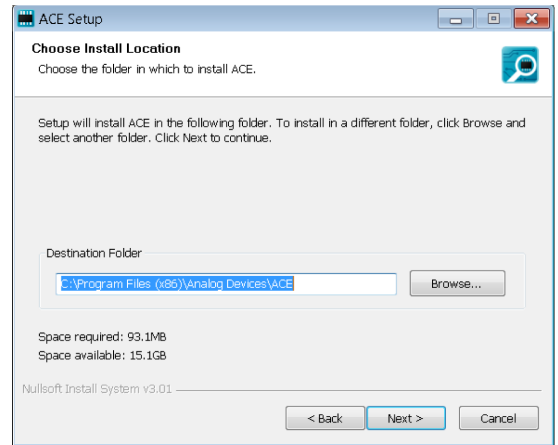

Figure 5. Choose Installation Location

7. The ACE Software components to install are preselected. Click **Install** (see [Figure 6](#)).

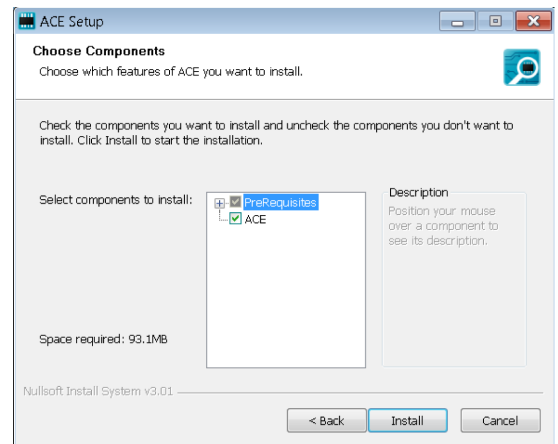

Figure 6. Choose Components

EVALUATION BOARD SOFTWARE

- 8. The **Windows Security** window appears. Click **Install** (see [Figure 7](#)). [Figure 8](#) shows the installation in progress. No action is required.

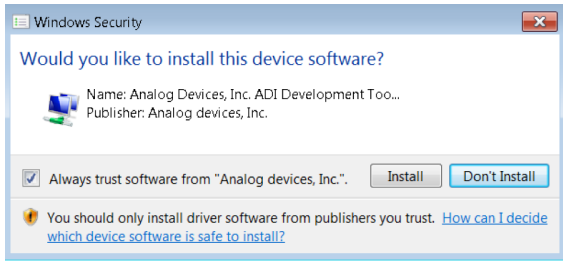

Figure 7. Windows Security Window

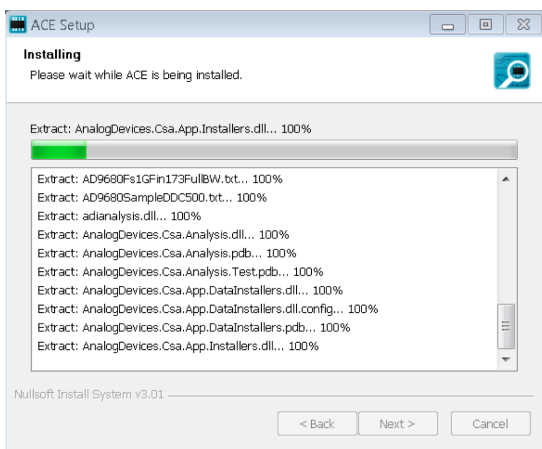

Figure 8. Installation in Progress

- 9. When the installation is complete, click **Next >** (see [Figure 9](#)), and then click **Finish** to complete the installation process.

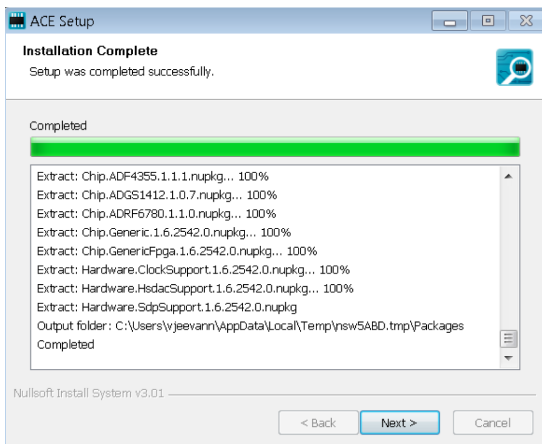

Figure 9. Installation Complete

ZedBoard Boot Procedure

Follow the next steps to load the image into the SD card and boot the ZedBoard to control the EV-ADuM7801-8FMCZ.

Loading Image on SD Card

To boot the ZedBoard and control the EV-ADuM7801-8FMCZ, install ADI Kuiper Linux on an SD card. Complete the instructions, which include where to download the SD card image, how to write it to the SD card, and how to configure the system are provided on the [Kuiper Linux](#) page.

Configuring the SD Card

Follow the configuration procedure under **Configuring the SD Card for FPGA Projects** on the Kuiper Linux page. Copy the following files onto the boot directory to configure the SD card:

- ▶ **ulmage** file for Zynq.
- ▶ **BOOT.BIN** specific to the EV-ADuM7801-8FMCZ + ZedBoard.
- ▶ **devicetree.dtb** for Zynq specific to the EV-ADuM7801-8FMCZ + ZedBoard.

Setting Up the Hardware

To setup the hardware, do the following steps:

1. Get the ZedBoard.
2. Set the jumpers, as shown in [Figure 10](#).

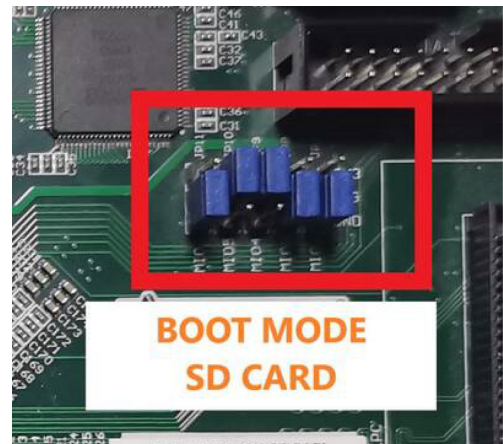

Figure 10. Jumpers Boot Mode SD Card

3. Before executing the steps 4, 5, and 6, make sure that VADJ jumper is set to 3.3V, as shown in [Figure 11](#) (install a header connector).

EVALUATION BOARD SOFTWARE

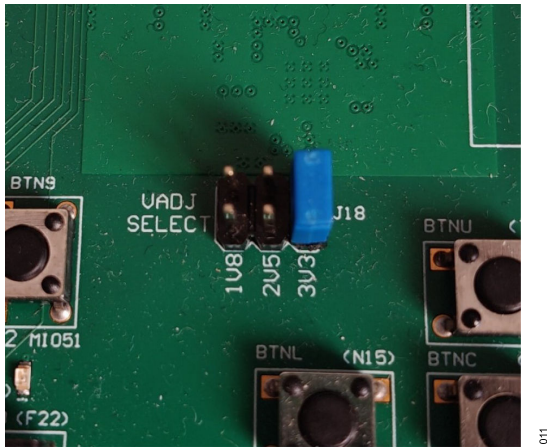

Figure 11. Jumper Position VADJ

4. Insert the SD card into the SD card interface connector (J12).
5. Connect USB UART J14 (micro USB) to the host PC.
6. Plug the power supply into the 12V power input connector (J20) (note that do not turn the device on).

EVALUATION BOARD SOFTWARE

EVALUATION BOARD SETUP PROCEDURES

The EV-ADuM7801-8FMCZ connects to the ZedBoard Zynq-7000. The ZedBoard is the communication link between the PC and the EV-ADuM7801-8FMCZ. A diagram of the connections between the EV-ADuM7801-8FMCZ and the ZedBoard is shown in [Figure 12](#).

Connecting the EV-ADuM7801-8FMCZ and the ZedBoard to the PC

After the [ACE Software](#) is installed, to set up the EV-ADuM7801-8FMCZ and the ZedBoard, do the following steps:

1. Ensure that all configuration links are in the proper positions, as described in [Table 2](#).
2. Connect the EV-ADuM7801-8FMCZ to the 160-way connector on the ZedBoard.

3. To power up the ZedBoard, insert the 12V, DC barrel jack (included in the ZedBoard kit) into the 12V power input connector (J20) (note that do not turn the device on) on the ZedBoard. Note that the EV-ADuM7801-8FMCZ does not require an external power supply adapter.
4. Connect the ZedBoard to the PC by the USB cable included in the ZedBoard kit.
5. Turn the ZedBoard on.
6. Wait ~30 seconds for the DONE LED to turn blue. This is near the DISP1.

Disconnecting the EV-ADuM7801-8FMCZ

Turn off the ZedBoard before disconnecting the EV-ADuM7801-8FMCZ from the ZedBoard.

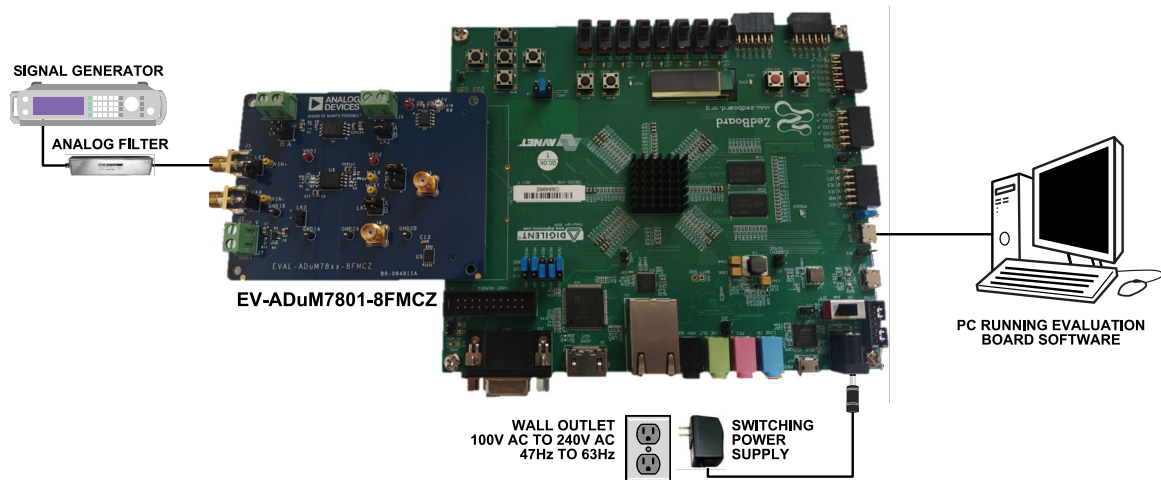

Figure 12. EV-ADuM7801-8FMCZ (Left) and ZedBoard (Right) Connection

ACE SOFTWARE OPERATION

LAUNCHING THE SOFTWARE

When the EV-ADuM7801-8FMCZ and the ZedBoard are properly connected to the PC, then to launch the [ACE Software](#), do the following steps:

1. In the **Start** menu of the PC, click **All Programs > Analog Devices > ACE > ACE.exe** to open the ACE software main window, as shown in [Figure 13](#).
2. Connect an input signal by the V_{IN+} J1 connector. Note that if the EV-ADuM7801-8FMCZ is not connected to the USB

port by the ZedBoard when the ACE software launches, the **ADuM7801 Eval Board** icon does not appear in the **Attached Hardware** section in ACE (see [Figure 13](#)). To make the **ADuM7801 Eval Board** icon appear, connect the EV-ADuM7801-8FMCZ and the ZedBoard to the USB port of the PC, wait a few seconds, and then follow the instructions in the dialog box that appears.

3. Double-click the **ADuM7801 Eval Board** icon (see [Figure 13](#)) to open the chip view window, as shown in [Figure 14](#).

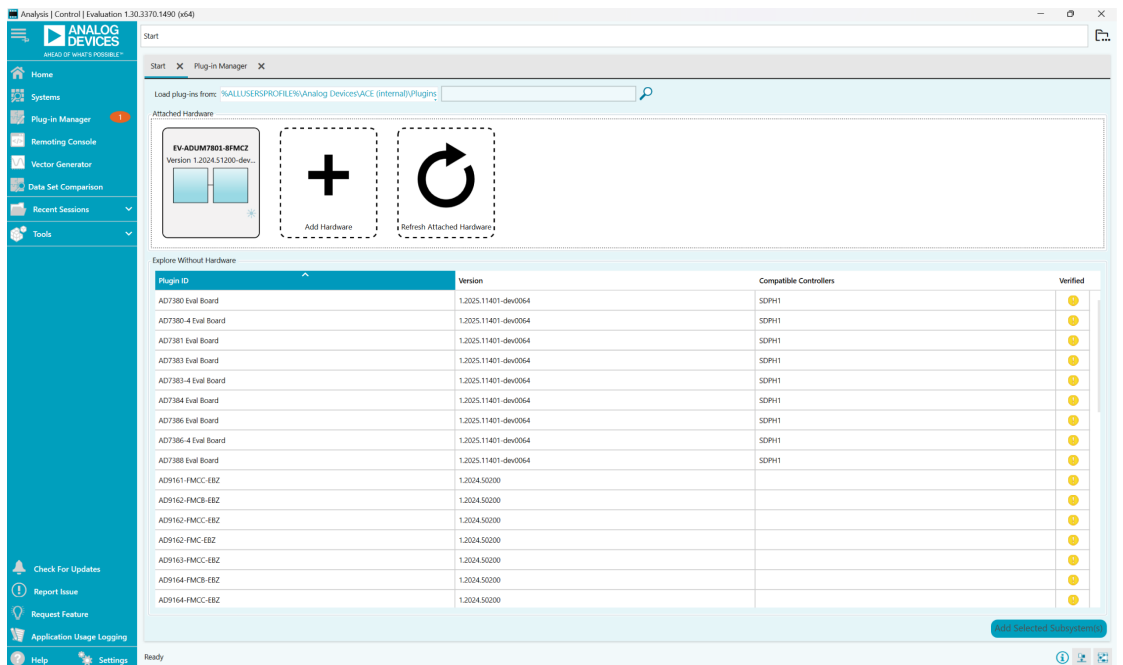

Figure 13. ACE Software Main Window

CHIP VIEW WINDOW FEATURES

After selecting the required clock frequency (maximum clock frequency: 25MHz), double-click the ADuM7801 diagram in the chip view window of the ACE Software (see Figure 14) to open the

analysis view window, as shown in Figure 15. The analysis view window contains the **Waveform**, **Histogram**, and **FFT** tabs on the left side of the window.

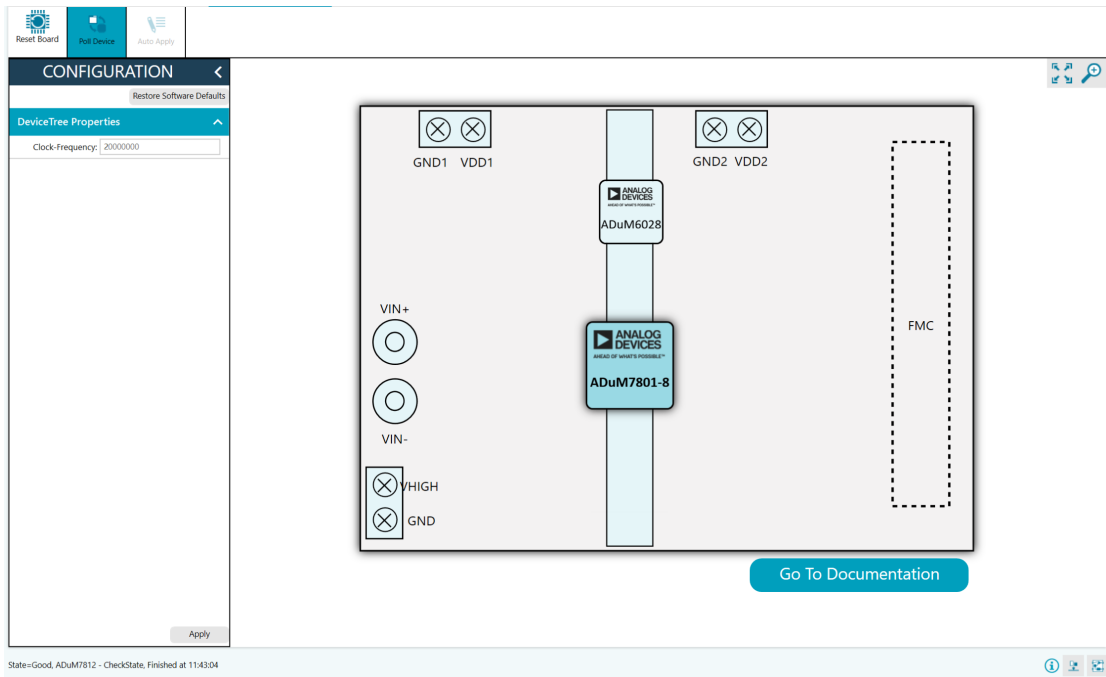

Figure 14. Chip View Window

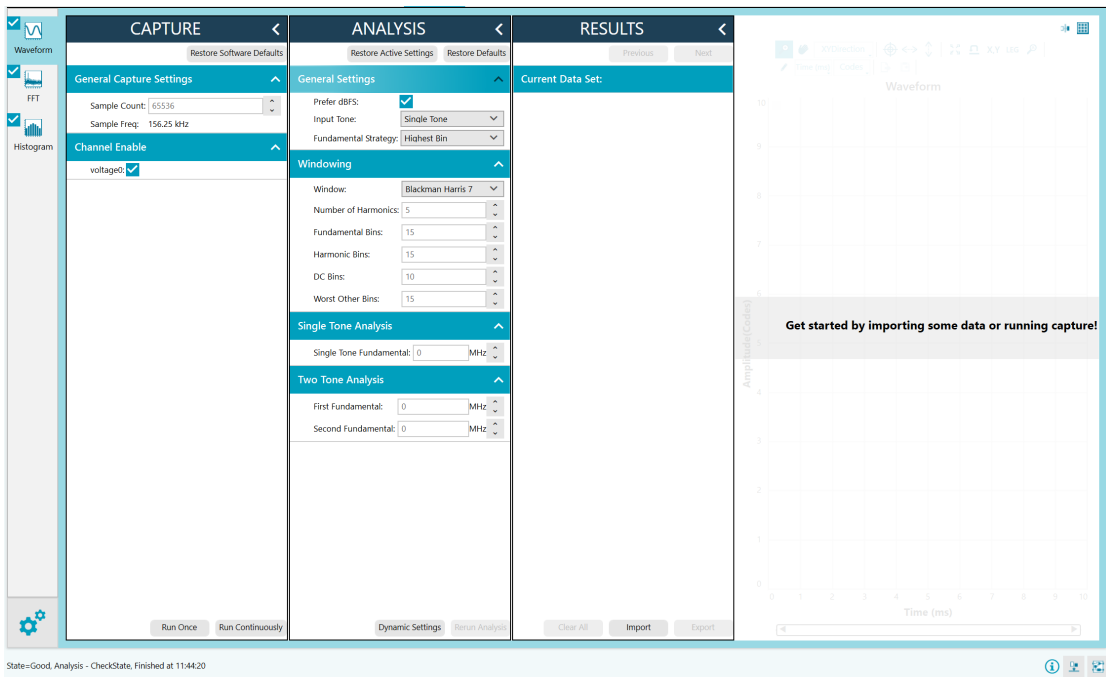

Figure 15. Analysis View Window

CHIP VIEW WINDOW FEATURES

WAVEFORM TAB

The **Waveform** tab in the analysis view window displays data in the form of time vs. discrete data values with the results (see [Figure 16](#)).

CAPTURE

The **CAPTURE** pane contains the capture settings. These settings reflect onto the registers automatically before data capture.

In the **General Capture Settings** section, the **Sample Count** field allows the user to select the number of samples per channel per capture (see [Figure 16](#)).

The **FPGA Settings** section contains the FPGA settings that specify the **Sample Frequency** used for the serial interface, as well as the **Decimation Ratio** used by the FPGA to filter the data (see [Figure 16](#)).

Click **Run Once** at the bottom of the **CAPTURE** pane to start a data capture of the samples at the sample rate specified in the **Sample Count** field (see [Figure 16](#)). These samples are stored on the ZedBoard and are only transferred to the PC when the sample frame is complete.

Click **Run Continuously** to start a data capture that gathers samples continuously with one batch of data at a time (see [Figure 16](#)).

RESULTS

The **Display Channels** section allows the user to select which channels to capture (see [Figure 16](#)). Data for a specific channel is only shown if that channel is selected before the capture.

The **Waveform** section displays the amplitude and sample frequency for the selected channel.

Click **Export** to export captured data (see [Figure 16](#)). The waveform, histogram, and FFT data is stored in .xml files along with the values of parameters at capture.

The **Waveform** graph shows each successive sample of the ADC output (see [Figure 16](#)). Zoom in on and pan over the **Waveform** graph using the embedded waveform tools above the graph. Select the channels to display in the **Display Channels** section.

Under the **Display Unit** drop-down menu, select **Codes** above the **Waveform** graph (see [Figure 16](#)) to select whether the **Waveform** graph displays in units of **Codes**, **Hex**, or **Volts**. The axis controls are dynamic.

Note that the corresponding axis width of the **Waveform** graph automatically adjusts to show the entire range of the ADC results after each batch of samples when either **xy scale dynamic** or **x scale dynamic** is selected. Select the dynamic using the **XYDirection** tool (see [Figure 16](#)).

HISTOGRAM TAB

The **Histogram** tab contains the **Histogram** graph and the **RESULTS** pane (see [Figure 17](#)).

Click the **RESULTS** pane to display the information related to the DC performance.

The **Histogram** graph displays the number of hits per code within the sampled data (see [Figure 17](#)). The **Histogram** graph also displays DC analysis and indicates the noise performance of the ADuM7801.

FFT TAB

The **FFT** tab displays fast Fourier transform (FFT) information for the last batch of samples gathered (see [Figure 18](#)).

The **General Settings** section on the **ANALYSIS** pane allows the user to set up the preferred configuration of the FFT analysis (see [Figure 18](#)). The fundamental is set manually.

The **Windowing** section on the **ANALYSIS** pane allows the user to select the windowing type used in the FFT analysis, the number of **Harmonic Bins**, and the number of **Fundamental Bins** that must be included (see [Figure 18](#)).

The **Single Tone Analysis** and **Two Tone Analysis** sections on the **ANALYSIS** pane allow the user to select the fundamental frequency included in the FFT analysis (see [Figure 18](#)). Use the **Two Tone Analysis** settings when analyzing two frequencies.

The **Signal** section on the **RESULTS** pane displays the **Sample Frequency**, **Sample Count**, **Fund Frequency**, and **Fund Power** (see [Figure 18](#)).

The **Noise** section on the **RESULTS** pane displays the **SNR** and other noise performance results (see [Figure 18](#)).

The **Distortion** section on the **RESULTS** pane displays the harmonic content of the sampled signal and the DC power when viewing the FFT analysis (see [Figure 18](#)).

EXITING THE SOFTWARE

To exit the [ACE Software](#), click **File**, and then click **Exit**.

CHIP VIEW WINDOW FEATURES

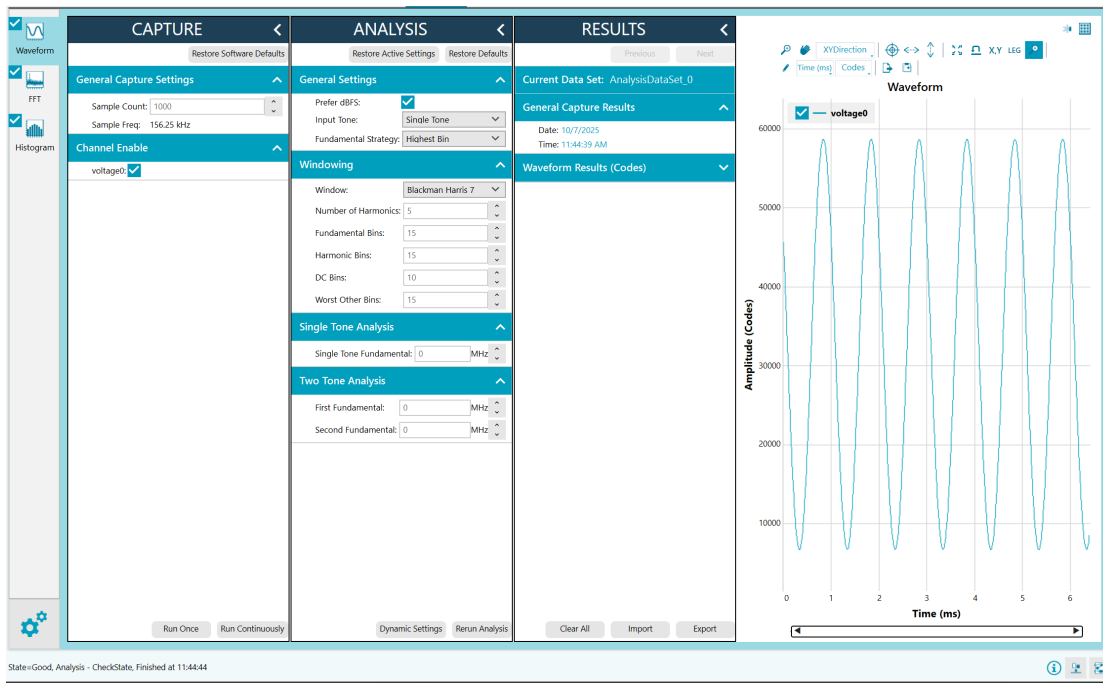

Figure 16. Waveform Tab

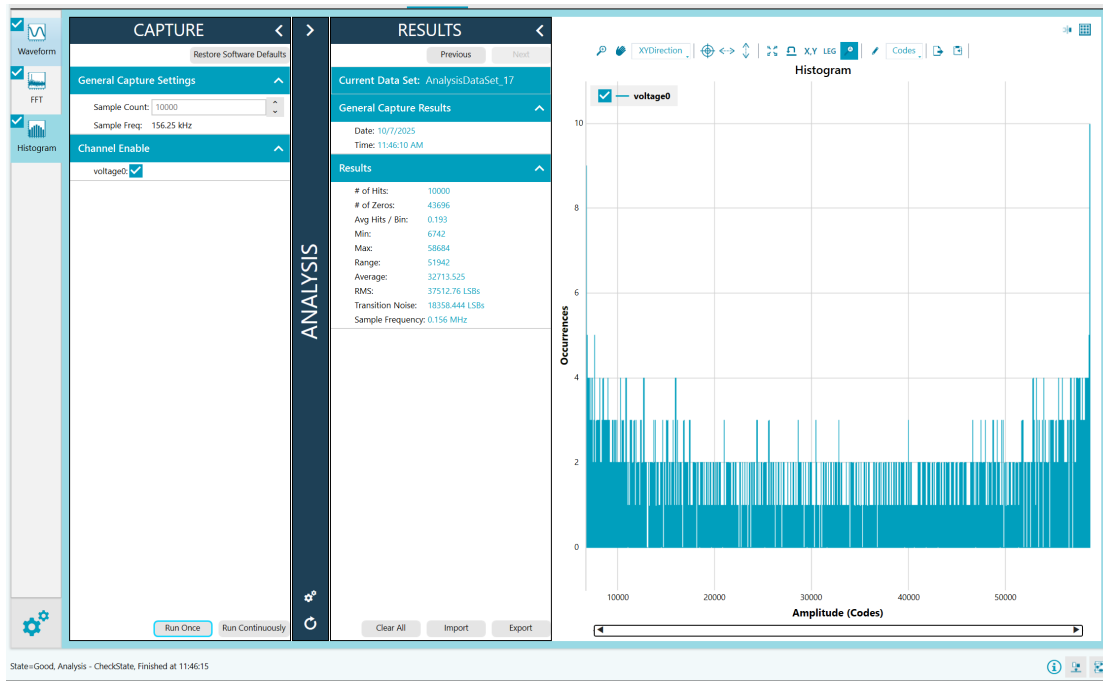

Figure 17. Histogram Tab

CHIP VIEW WINDOW FEATURES

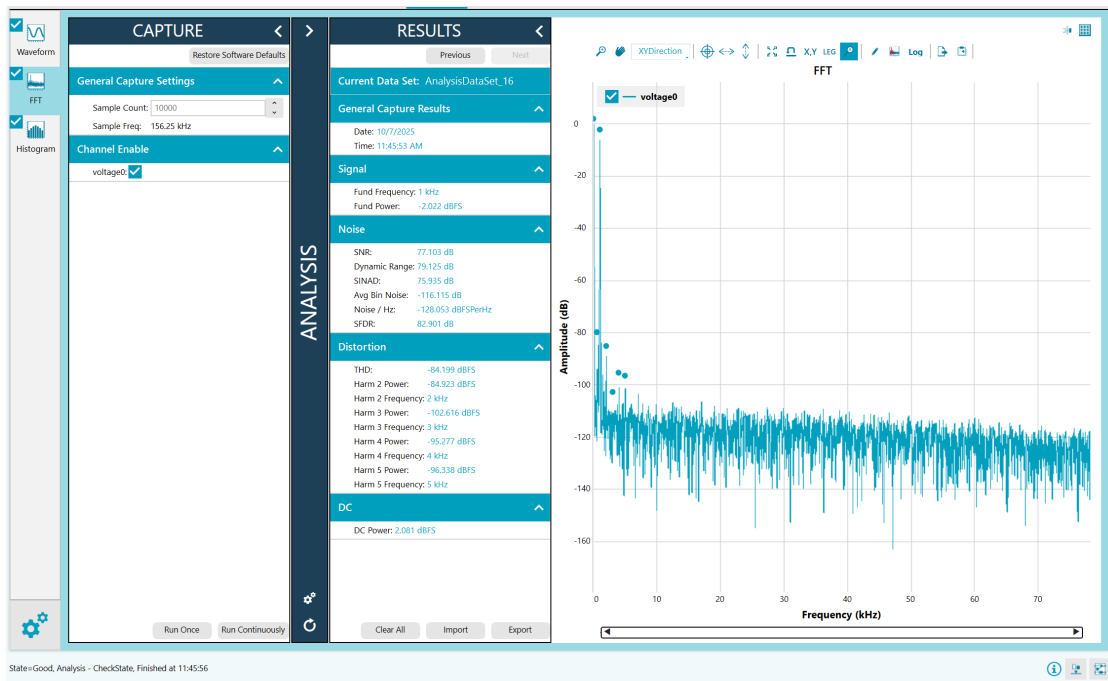

Figure 18. FFT Tab

EVALUATION BOARD SCHEMATIC AND SILKSCREENS

610

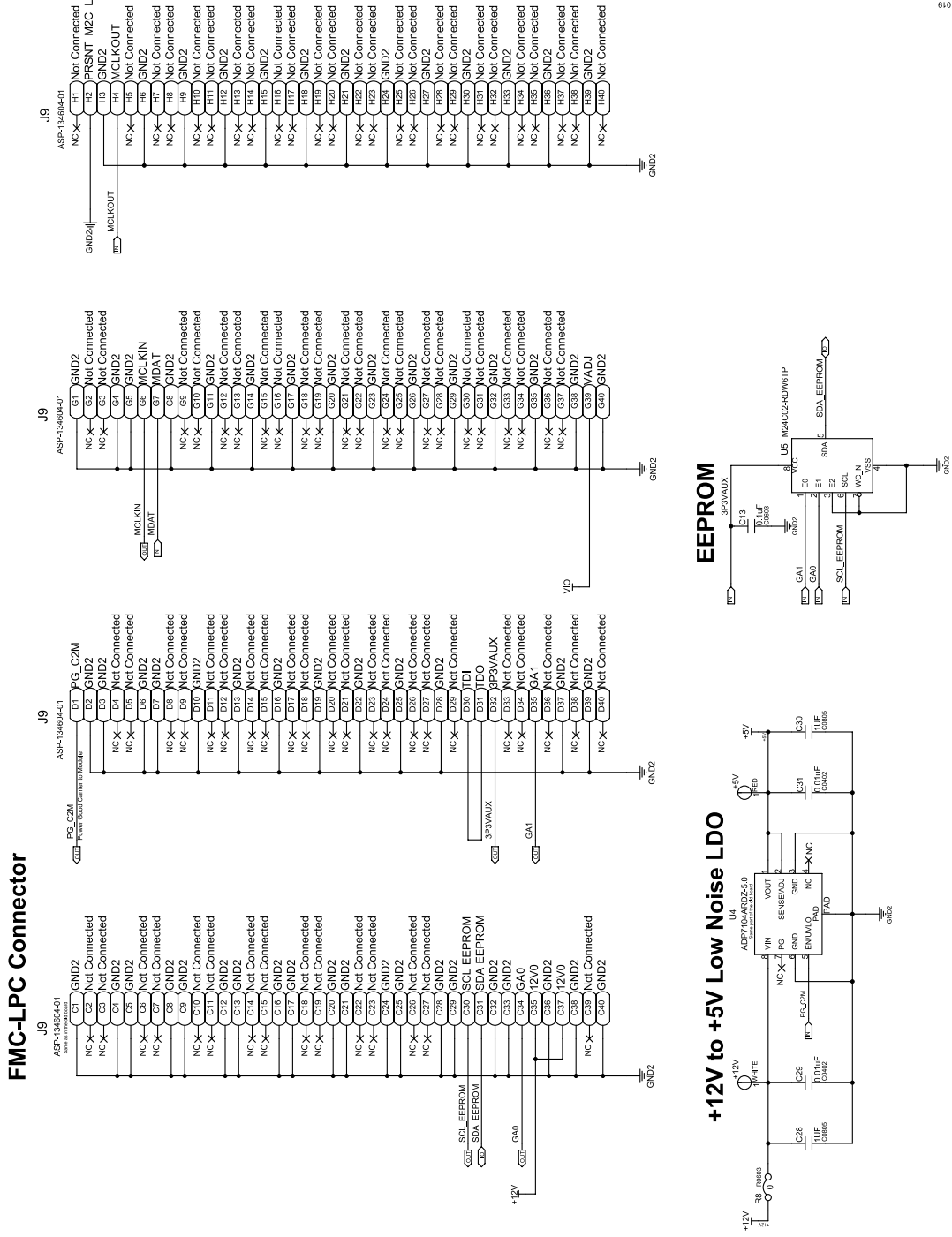

Figure 19. EV-ADuM7801-8FMCZ Evaluation Board Schematic Page 1

EVALUATION BOARD SCHEMATIC AND SILKSCREENS

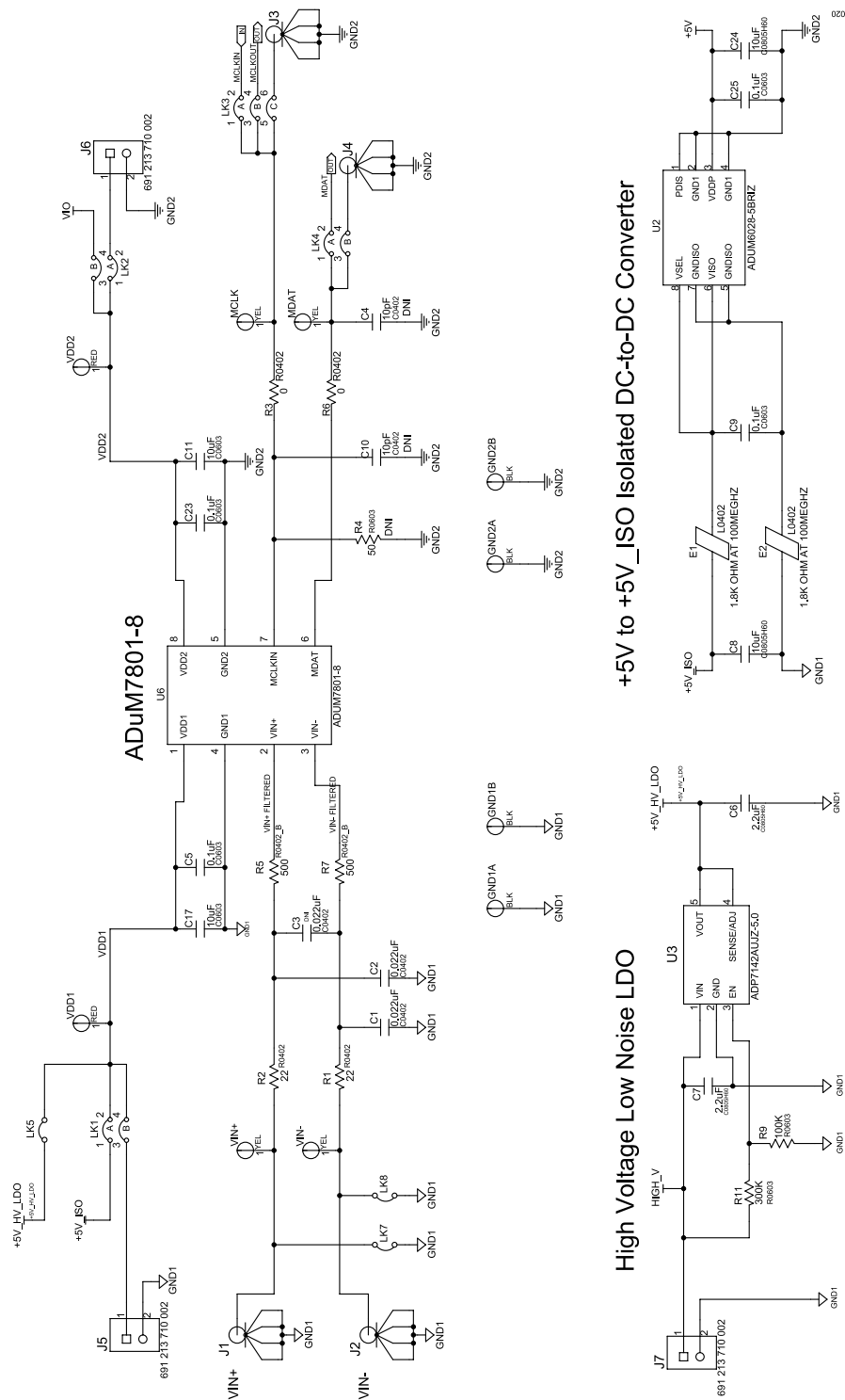

Figure 20. EV-ADuM7801-8FMCZ Evaluation Board Schematic Page 2

EVALUATION BOARD SCHEMATIC AND SILKSCREENS

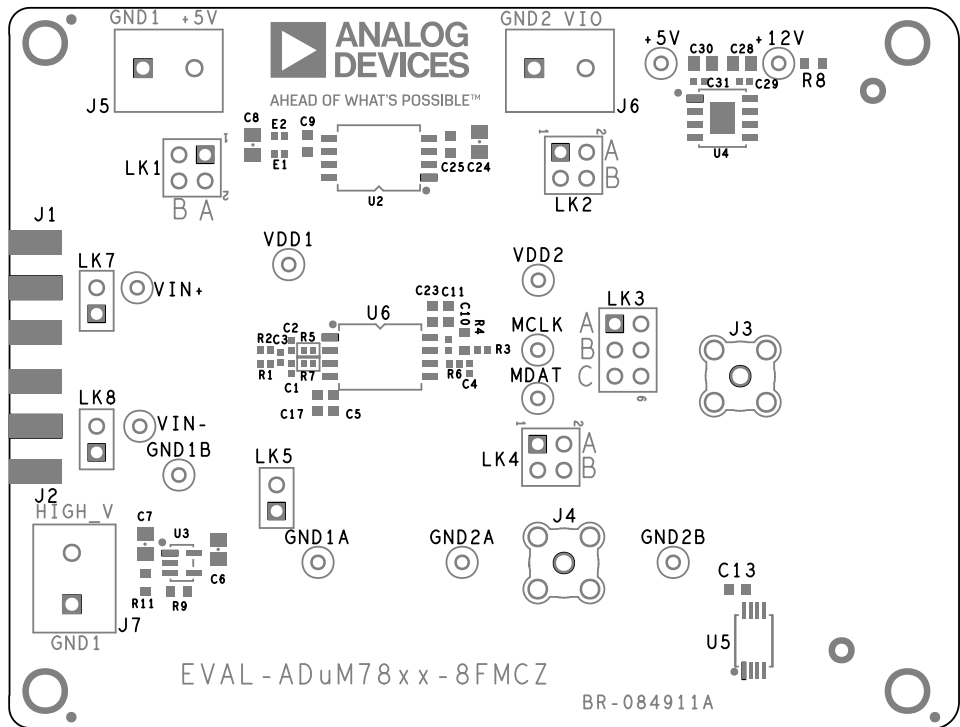

Figure 21. EV-ADuM7801-8FMCZ Top Silkscreen

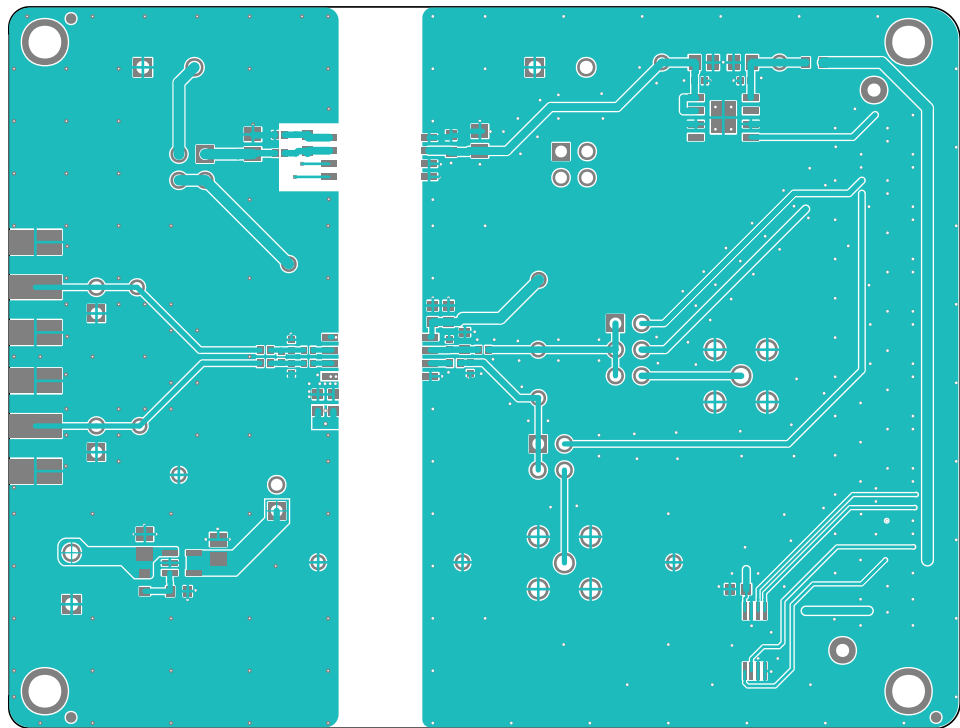

Figure 22. EV-ADuM7801-8FMCZ Top Copper

EVALUATION BOARD SCHEMATIC AND SILKSCREENS

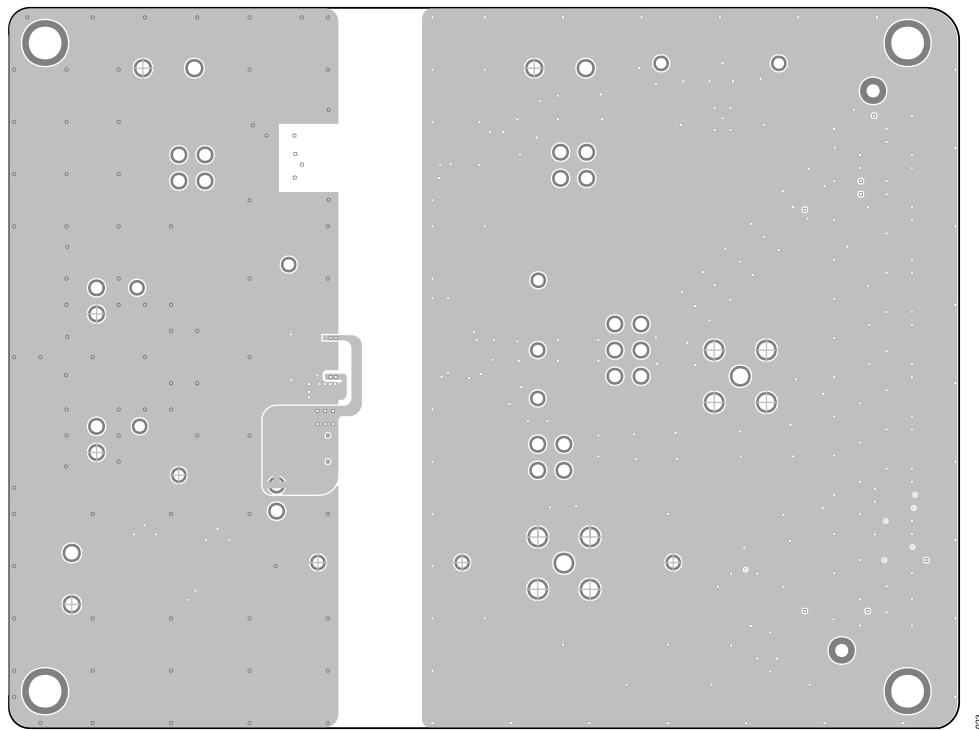

Figure 23. EV-ADuM7801-8FMCZ Inner Layer 1 Copper

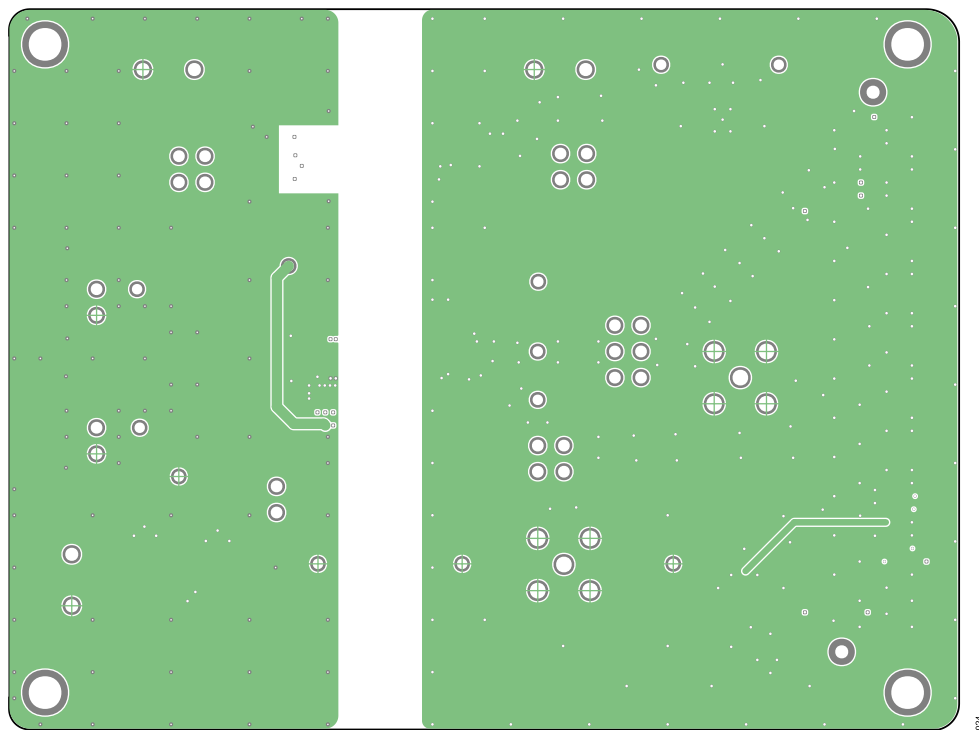

Figure 24. EV-ADuM7801-8FMCZ Inner Layer 2 Copper

EVALUATION BOARD SCHEMATIC AND SILKSCREENS

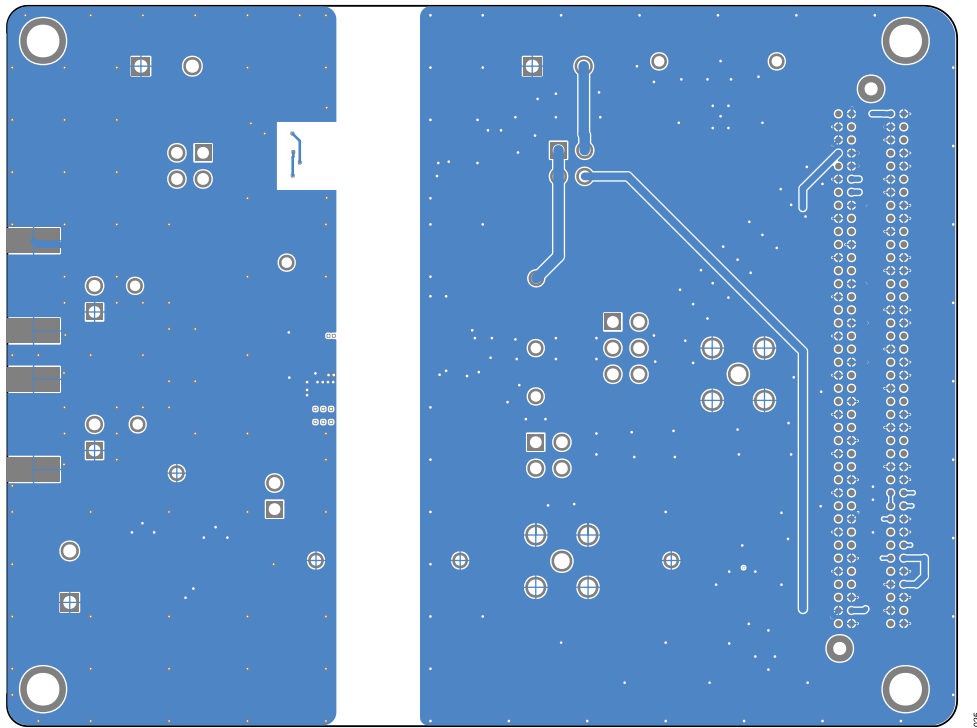

Figure 25. EV-ADuM7801-8FMCZ Bottom Copper

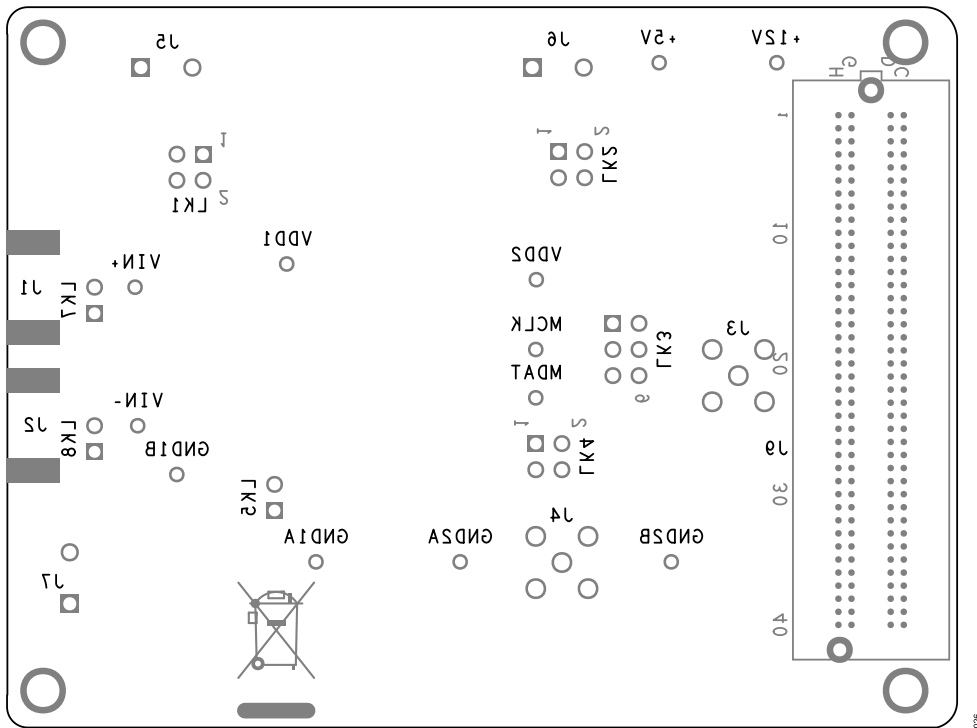

Figure 26. EV-ADuM7801-8FMCZ Bottom Silkscreen

BILL OF MATERIALS

Table 4. Bill of Materials for EV-ADuM7801-8FMCZ

Quantity	Reference Designator	Description	Manufacturer	Part Number
1	+12V	Connector, PCB test point white	Vero Technologies	20-313139
3	+5V, VDD1, VDD2	Connectors, PCB test points red	Vero Technologies	20-313137
2	C1, C2	Ceramic capacitors, 0.022 μ F, 25V, 10%, X7R, 0402	Murata	GRM155R71E223KA61D
2	C11, C17	Ceramic capacitors, 10 μ F, 16V, 10%, X5R, 0603	Murata	GRM188R61C106KAALD
5	C5, C9, C13, C23, C25	Ceramic capacitors, 0.1 μ F, 16V, 10%, X7R, 0603	Würth Elektronik	885012206046
2	C8, C24	Ceramic capacitors, 10 μ F, 10V, 10%, X7R, 0805	Würth Elektronik	885012207026
2	C28, C30	Ceramic capacitors, 1 μ F, 100V, 10%, X7R, 0805, AEC-Q200	Kyocera	08051C105K4T2A
2	C29, C31	Ceramic capacitors, 0.01 μ F, 25V, 10%, X8R, 0402	TDK	C1005X8R1E103K050BA
2	C6, C7	Ceramic capacitors, 2.2 μ F, 50V, 10%, X7R, 0805	Taiyo Yuden	UMK212BB7225KG-T
2	E1, E2	Inductive ferrite beads, 2.2 Ω maximum DC resistance, 0.2A	Murata	BLM15HD182SN1D
4	GND1A, GND1B, GND2A, GND2B	Connectors, PCB test points black	Vero Technologies	20-2137
2	J1, J2	PCB connectors, SMA, jack, female socket	Johnson	142-0701-851
2	J3, J4	PCB connectors, SMA, jack, female socket	Molex	73391-0070
3	J5, J6, J7	PCB connectors, terminal blocks, 5.0mm pitch, 16AWG to 26AWG	Würth Elektronik	691213710002
1	J9	PCB connector, array, male pins, 160-positions	Samtec	ASP-134604-01
3	LK1, LK2, LK4	PCB connectors, header, 2 rows, vertical, 4-way, 2X M000385	Würth Elektronik	61300421121
1	LK3	PCB connector, header, 2 rows, vertical, 6-way, 3X M000385	Würth Elektronik	61300621121
3	LK5, LK7, LK8	PCB connectors, header, 1 row, 2-way	Harwin	M20-9990246
4	MCLK, MDAT, VIN+, VIN-	Connectors, PCB test points yellow	Vero Technologies	20-313140
2	R1, R2	Resistors, SMD, 22 Ω , 1%, 1/10W, 0402, AEC-Q200	Panasonic	ERJ-2RKF22R0X
1	R11	Resistor, SMD, 300k Ω , 1%, 1/10W, 0603	Vishay	CRCW0603300KFKEAC
2	R3, R6	Resistors, SMD, 0 Ω , 1/10W, 0402, AEC-Q200	Panasonic	ERJ-2GE0R00X
2	R5, R7	Resistors, SMD, 500 Ω , 2%, 1/20W, 0402	Vishay	CH0402-500RGFPA
1	R8	Resistor, SMD, 0 Ω , 1/10W, 0603, AEC-Q200	Panasonic	ERJ-3GEY0R00V
1	R9	Resistor, SMD, 100k Ω , 1%, 1/10W, 0603, AEC-Q200	Panasonic	ERJ-3EKF1003V
1	U2	Low emission, 5kV isolated DC-to-DC converter	Analog Devices, Inc.	ADuM6028-5BRIZ
1	U3	Low noise, CMOS LDO linear regulator, 5V _{OUT}	Analog Devices, Inc.	ADP7142AUJZ-5.0-R7
1	U4	Low noise, CMOS LDO, 5V _{OUT}	Analog Devices, Inc.	ADP7104ARDZ-5.0-R7
1	U5	2kbit, serial I ² C bus, EEPROM	ST Microelectronics	M24C02-RDW6TP
1	U6	5.7kV rms isolated 25MHz ADC with sigma-delta modulated bit stream output	Analog Devices, Inc.	ADuM7801-8BRIZ

NOTES

**ESD Caution**

ESD (electrostatic discharge) sensitive device. Charged devices and circuit boards can discharge without detection. Although this product features patented or proprietary protection circuitry, damage may occur on devices subjected to high energy ESD. Therefore, proper ESD precautions should be taken to avoid performance degradation or loss of functionality.

Legal Terms and Conditions

By using the evaluation board discussed herein (together with any tools, components documentation or support materials, the "Evaluation Board"), you are agreeing to be bound by the terms and conditions set forth below ("Agreement") unless you have purchased the Evaluation Board, in which case the Analog Devices Standard Terms and Conditions of Sale shall govern. Do not use the Evaluation Board until you have read and agreed to the Agreement. Your use of the Evaluation Board shall signify your acceptance of the Agreement. This Agreement is made by and between you ("Customer") and Analog Devices, Inc. ("ADI"), with its principal place of business at One Analog Way, Wilmington, MA 01887-2356, U.S.A. Subject to the terms and conditions of the Agreement, ADI hereby grants to Customer a free, limited, personal, temporary, non-exclusive, non-sublicensable, non-transferable license to use the Evaluation Board FOR EVALUATION PURPOSES ONLY. Customer understands and agrees that the Evaluation Board is provided for the sole and exclusive purpose referenced above, and agrees not to use the Evaluation Board for any other purpose. Furthermore, the license granted is expressly made subject to the following additional limitations: Customer shall not (i) rent, lease, display, sell, transfer, assign, sublicense, or distribute the Evaluation Board; and (ii) permit any Third Party to access the Evaluation Board. As used herein, the term "Third Party" includes any entity other than ADI, Customer, their employees, affiliates and in-house consultants. The Evaluation Board is NOT sold to Customer; all rights not expressly granted herein, including ownership of the Evaluation Board, are reserved by ADI. CONFIDENTIALITY. This Agreement and the Evaluation Board shall all be considered the confidential and proprietary information of ADI. Customer may not disclose or transfer any portion of the Evaluation Board to any other party for any reason. Upon discontinuation of use of the Evaluation Board or termination of this Agreement, Customer agrees to promptly return the Evaluation Board to ADI. ADDITIONAL RESTRICTIONS. Customer may not disassemble, decompile or reverse engineer chips on the Evaluation Board. Customer shall inform ADI of any occurred damages or any modifications or alterations it makes to the Evaluation Board, including but not limited to soldering or any other activity that affects the material content of the Evaluation Board. Modifications to the Evaluation Board must comply with applicable law, including but not limited to the RoHS Directive. TERMINATION. ADI may terminate this Agreement at any time upon giving written notice to Customer. Customer agrees to return to ADI the Evaluation Board at that time. LIMITATION OF LIABILITY. THE EVALUATION BOARD PROVIDED HEREUNDER IS PROVIDED "AS IS" AND ADI MAKES NO WARRANTIES OR REPRESENTATIONS OF ANY KIND WITH RESPECT TO IT. ADI SPECIFICALLY DISCLAIMS ANY REPRESENTATIONS, ENDORSEMENTS, GUARANTEES, OR WARRANTIES, EXPRESS OR IMPLIED, RELATED TO THE EVALUATION BOARD INCLUDING, BUT NOT LIMITED TO, THE IMPLIED WARRANTY OF MERCHANTABILITY, TITLE, FITNESS FOR A PARTICULAR PURPOSE OR NON-INFRINGEMENT OF INTELLECTUAL PROPERTY RIGHTS. IN NO EVENT WILL ADI AND ITS LICENSORS BE LIABLE FOR ANY INCIDENTAL, SPECIAL, INDIRECT, OR CONSEQUENTIAL DAMAGES RESULTING FROM CUSTOMER'S POSSESSION OR USE OF THE EVALUATION BOARD, INCLUDING BUT NOT LIMITED TO LOST PROFITS, DELAY COSTS, LABOR COSTS OR LOSS OF GOODWILL. ADI'S TOTAL LIABILITY FROM ANY AND ALL CAUSES SHALL BE LIMITED TO THE AMOUNT OF ONE HUNDRED US DOLLARS (\$100.00). EXPORT. Customer agrees that it will not directly or indirectly export the Evaluation Board to another country, and that it will comply with all applicable United States federal laws and regulations relating to exports. GOVERNING LAW. This Agreement shall be governed by and construed in accordance with the substantive laws of the Commonwealth of Massachusetts (excluding conflict of law rules). Any legal action regarding this Agreement will be heard in the state or federal courts having jurisdiction in Suffolk County, Massachusetts, and Customer hereby submits to the personal jurisdiction and venue of such courts. The United Nations Convention on Contracts for the International Sale of Goods shall not apply to this Agreement and is expressly disclaimed. All Analog Devices products contained herein are subject to release and availability.

