

## Data Center Thermal Measurement and Leak Sensing System

### General Description

The EVAL-ADT7604-AZ features the ADT7604 20-channel, data center thermal measurement and leak sensing system with EEPROM. The ADT7604 measures a wide variety of temperature sensors and digitally outputs the result in °C, °F, or  $\Omega$  with 0.1°C accuracy and 0.001°C resolution. All signals are buffered and simultaneously digitized with two high-accuracy, 24-bit  $\Delta$ - $\Sigma$  ADCs.

The ADT7604 features accurate temperature measurement with copper trace sensors, which are thin copper traces integrated into PCBs or laminate substrates, and can be placed in mechanically hard-to-reach places to sense thermal hotspots. The ADT7604 also accurately measures resistive leak detectors for safety monitoring in liquid-handling systems.

The EVAL-ADT7604-AZ is a thermal measurement evaluation board with two copper trace sensors, two leak detectors, a 1k $\Omega$  thermistor and a PT-100 RTD. When connected to a DC2026C Linduino demo circuit and a host PC, the EVAL-ADT7604-AZ reports temperature, resistance, and fault status from multiple types of sensors through the graphical user interface (GUI).

The copper trace sensors require a one-time calibration prior to operation. The leak detection sensors can be configured to report either raw resistance between the metal traces or the percentage of sensor coverage. See the Calibration sections for detailed setup procedures.

The GUI supports the evaluation of all onboard sensors as well as external custom sensors: a custom copper trace sensor connected to J1 and a custom leak detection sensor connected to J3.

The ADT7604 is available in a 48-lead plastic LQFP package. The ADT7604 data sheet gives a complete description of this part, its operation, and applications information. The ADT7604 data sheet must be read in conjunction with this user guide to properly use the evaluation circuit EVAL-ADT7604-AZ.

### EVAL-ADT7604-AZ Setup Diagram

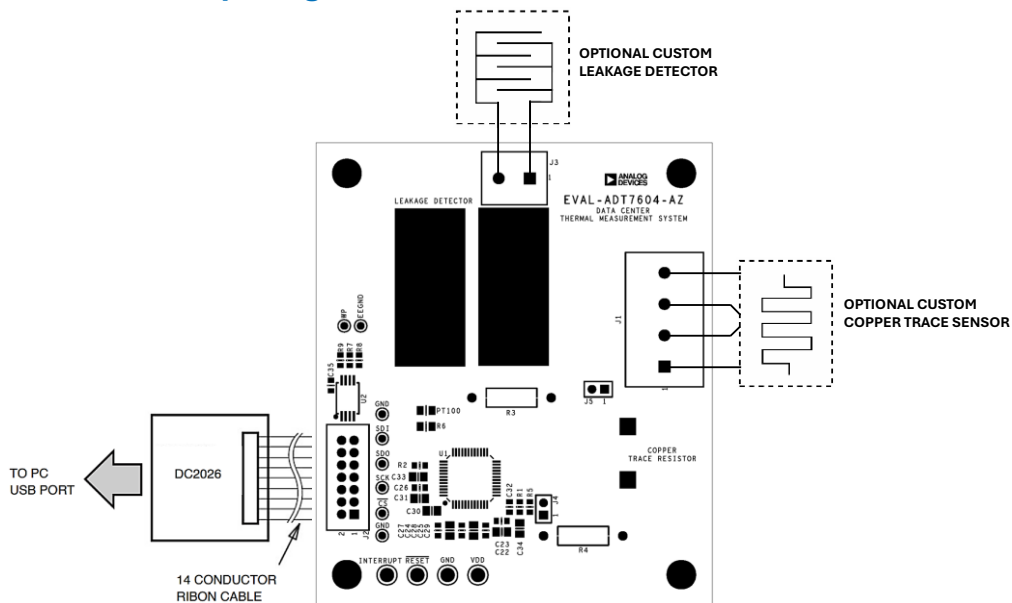

Figure 1. EVAL-ADT7604-AZ Setup Diagram

## Quick Start Procedure

### Evaluation Board Contents

- EVAL-ADT7604-AZ board

### Equipment Needed

- EVAL-ADT7604-AZ board
- DC2026C EV kit
- PC

### Procedure

The EVAL-ADT7604-AZ requires minimal setup for device evaluation. See [Figure 1](#) for the proper connection diagram between the EVAL-ADT7604-AZ, the DC2026C Linduino, and the host PC. To begin evaluation, complete the following steps:

1. Download ADT7604 software “ADT7604\_v\_1\_14\_2.zip”, unzip and launch “ADT7604.exe” evaluation software on the host PC.
2. Select **Configuration** on the top banner, and load the configuration file available on the product webpage.

### Copper Trace Sensor Measurement Setup

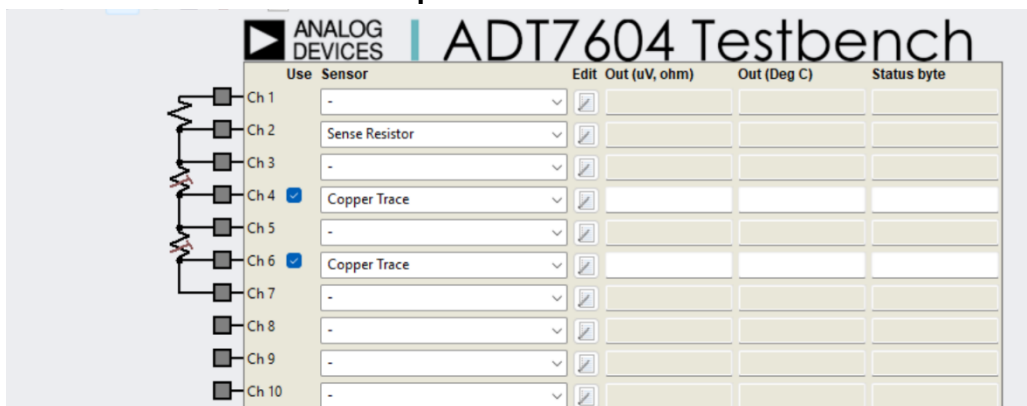

Figure 2. ADT7604 Copper Trace Setup

Calibration of the two copper trace sensors is required prior to operation. Complete the following procedure:

1. Click the **Run** button.
2. Select the appropriate COM port used to connect the DC2026C to the host PC and click **OK**. Measurement begins automatically.
3. Record the resistance and temperature of the CH4 sensor: Record the resistance value  $R(T_0)$  displayed at CH4 **Out (uV, ohm)**, and record the temperature output  $T_0$  at CH18 **Out (Deg C)**.
4. To configure CH4, click the notepad icon in the **Edit** column of CH4; a dialog window is displayed as shown in [Figure 3](#).

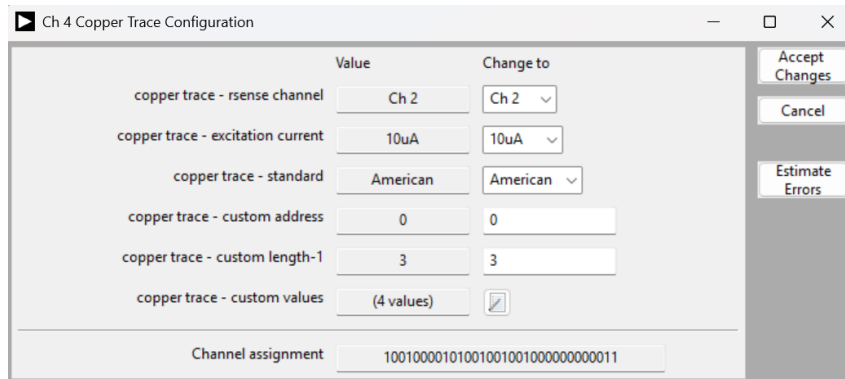

Figure 3. Copper Trace Configuration Window

- In the configuration window, click the notepad icon next to **copper trace – custom values**. A window appears as shown in [Figure 4](#).

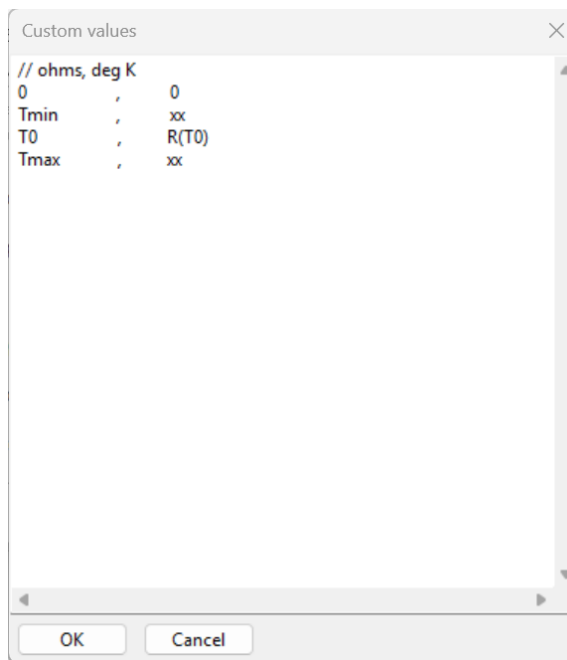

Figure 4. Copper Trace Sensor Custom Data Table

- Enter 0,0 as the first data pair in the table.
- Enter at least three additional data pairs corresponding to: (1) minimum expected temperature, (2) room temperature, and (3) maximum expected temperature. For example, for PCB temperature measurement, typical values are a minimum temperature of -40°C, room temperature  $T_0$  measured in step 3, and maximum room temperature of +150°C. Note that all temperature values entered in the table must be in Kelvin.

Calculate the copper trace sensor resistance at a given temperature using the following equation:

$$R(T) = R(T_0) + \alpha \times R(T_0) \times (T - T_0)$$

where:

$R(T)$  = Resistance at the target temperature

$R(T_0)$  = Measured resistance at step 3

$T_0$  = Measured temperature at step 3 (Celsius or Kelvin)

$\alpha$  = Temperature coefficient of copper resistance

$T$  = Target temperature, unit must match  $T_0$

8. For the second data pair, use the equation above to calculate  $R(T_{MIN})$  at the minimum expected temperature, followed by a comma and the temperature  $T_{MIN}$  in Kelvin.
9. For the third data pair, enter  $R(T_0)$  from step 3, followed by a comma and  $T_0$  recorded from step 3 in Kelvin.
10. For the fourth data pair, use the equation above to calculate  $R(T_{MAX})$  at the maximum expected temperature, followed by a comma and  $T_{MAX}$  in Kelvin.
11. Enter all data pairs into the table. See the example in [Figure 4](#).
12. Click **OK** and update **copper trace – custom length-1** to 3.
13. Click the **Accept Changes** button in the top right corner.
14. Repeat steps 1 through 12 for the CH6 copper trace sensor.

To use an external custom copper trace sensor connected at either end of the sensor to J1 and remove jumper J5. A one-time calibration is required for each copper trace sensor. For calibration of the custom copper trace sensor, see the steps above.

### Leakage Detector Measurement Setup

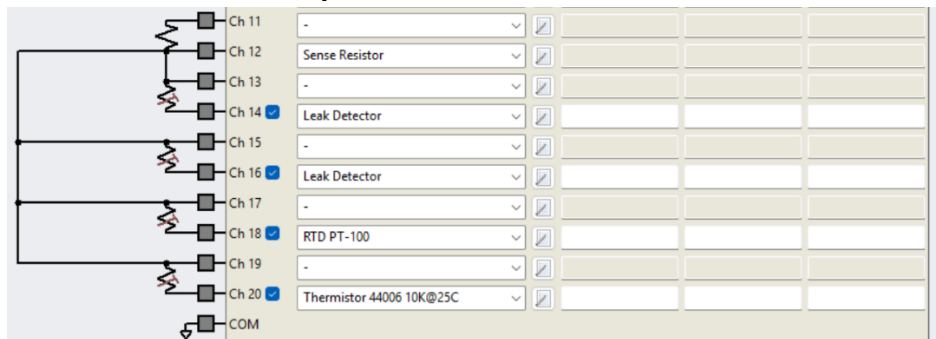

Figure 5. ADT7604 Leakage Detector Setup

The leak detector can be used with the GUI to display its resistance. Additionally, the leak detector can be calibrated so that the GUI reports the percentage of the sensor liquid coverage. Calibration can be performed for the onboard leak detectors or for a custom leak detector connected through J3. Complete the following procedure to calibrate the leak detection sensor for percent coverage reporting:

1. With no liquid present on the leak detector, the reported resistance is 2097151Ω, use 2097151Ω and 273.15 as the first data pair in the table.
2. Cover 25% of the sensor with the cooling liquid to be detected.
3. Click **Run** in the GUI.
4. Select the appropriate COM port used to connect the DC2026C to the host PC and click **OK**.
5. Record the resistance output at CH14 under **Out (uV, ohm)**.
6. Convert the percentage of coverage (25%) into the coverage for data table by using equation:  $25\% \times 100 + 273.15 = 298.15$ . Use the resistance result in step 5 and 298.15 as the second data pair in the table in step 8.
7. Repeat steps 2 through 6 for 50%, 75%, and 99%.
8. Complete the following table to obtain the required data pairs:

RESISTANCE FOR DATA TABLE (Ω)	COVERAGE INFO FOR DATA TABLE	ACTUAL PERCENTAGE OF COVERAGE (%)
2097151	273.15	0
xx	298.15	25
xx	323.15	50
xx	348.15	75
xx	372.15	99
0	373.15	100

The final point is necessary for proper IC operation.

- Click the notepad icon in the **Edit** column for CH14. A dialog window is displayed as shown in [Figure 6](#).

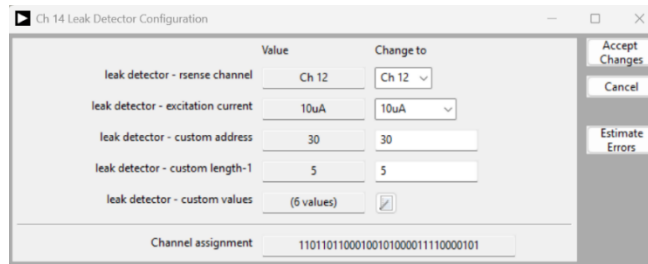

Figure 6. Leakage Detector Configuration Window

- Click the notepad icon next to **leak detector – custom values** and enter the ordered pairs obtained from the table shown in [Figure 7](#).

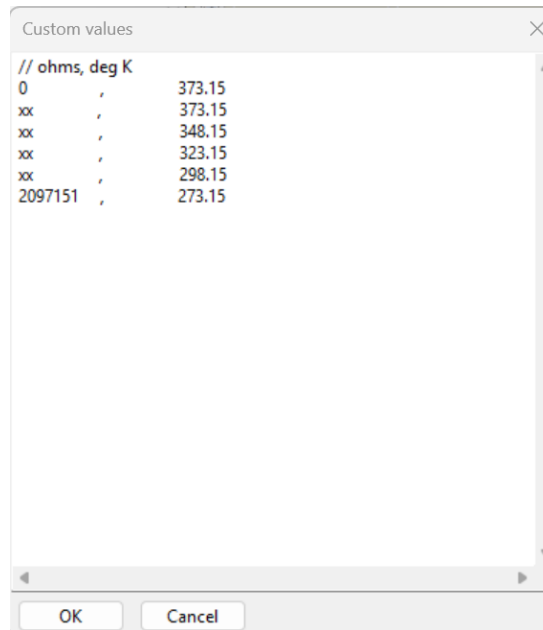

Figure 7. Leak Detector Custom Table

- Click **OK** and update the “**leak detector – custom length-1**” to be 5.
- Click the **Accept Changes** button in the top right corner.

Additional data pairs can be entered to improve the accuracy of the percentage coverage reporting.

## Ordering Information

PART	TYPE
EVAL-ADT7604-AZ	EV Kit

## EVAL-ADT7604-AZ Bill of Materials

ITEM	QTY	REFERENCE	DESCRIPTION	MANUFACTURER/PART NUMBER
1	21	C1, C2, C3, C4, C5, C6, C7, C8, C9, C10, C11, C12, C13, C14, C15, C16, C17, C18, C19, C20, C21	CAP CER 100pF 100V 5% C0G 0603	KEMET C0603C101J1GAC
2	7	C22, C24, C25, C30, C31, C33, C34	CAP CER 10µF 10V 10% X7R 0805	MURATA GCM21BR71A106KE22K
3	7	C23, C26, C27, C28, C29, C32, C35	CAP CER 0.1µF 25V 10% X7R 0603	WURTH ELECTRONICS INC 885012206071
4	1	J1	CONNECTOR THROUGH-HOLE PCB TERMINAL BLOCK 4 PINS	PHOENIX CONTACT 1869237
5	1	J2	CONNECTOR MALE THROUGH-HOLE 14 PINS	MOLEX 87831-1420
6	1	J3	CONNECTOR THROUGH-HOLE PCB TERMINAL BLOCK 2 PINS	PHOENIX CONTACT 1729018
7	2	J4, J5	CONNECTOR MALE PCB BLOCK 2 PINS	WURTH ELEKTONIK 62000211121
8	1	PT100	RES TEMP SENSOR 100Ω 1% 0805	VISHAY PTS08051B100RP100
9	1	R1	RES SMT 1Ω 5% 0603	VISHAY CRCW06031R00JN
10	1	R2	RES SMD 100kΩ 1 0603 AEC-Q200	VISHAY CRCW0603100KFKEA
11	1	R3	RES TH 1kΩ 0.01%	VISHAY PTF561K0000TYEK
12	1	R4	RES TH 100Ω 0.01%	VISHAY PTF56100R00TYEK
13	1	R5	RES SMD 150Ω 5% 0603 AEC-Q200	PANASONIC ERJ-3GEYJ151V
14	1	R6	THERMISTOR SMD 1kΩ 5% 0805	TDK B57620C5103J062
15	3	R7, R8, R9	RES SMD 4.99kΩ 1% 0603 AEC-Q200	PANASONIC ERJ-3EKF4991V
16	1	U1	IC-ADI, DATA CENTER THERMAL MEASUREMENT SYSTEM MEASURES RTDS, THERMISTORS AND PCB COPPER TRACE SENSORS	ANALOG DEVICES INC ADT7604BSTZ
17	1	U2	IC EEPROM SMD TSSOP	MICROCHIP TECHNOLOGY 24LC025-I/ST

EVAL-ADT7604-AZ Schematic

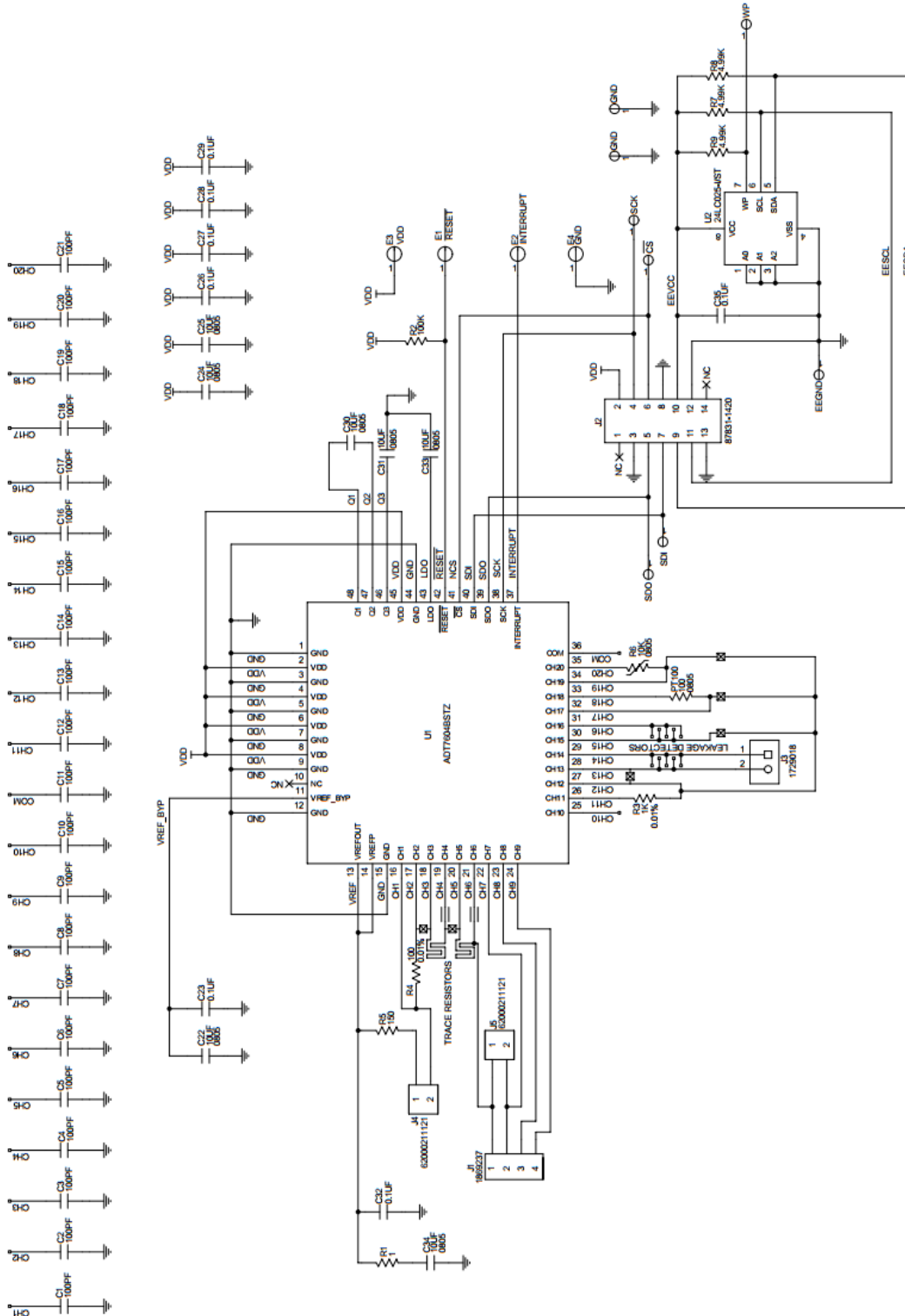

Figure 8. Schematic for EVAL-ADT7604-AZ

**Revision History**

<b>REVISION NUMBER</b>	<b>REVISION DATE</b>	<b>DESCRIPTION</b>	<b>PAGES CHANGED</b>
0	5/26	Initial release	—

## Notes

ALL INFORMATION CONTAINED HEREIN IS PROVIDED “AS IS” WITHOUT REPRESENTATION OR WARRANTY. NO RESPONSIBILITY IS ASSUMED BY ANALOG DEVICES FOR ITS USE, NOR FOR ANY INFRINGEMENTS OF PATENTS OR OTHER RIGHTS OF THIRD PARTIES THAT MAY RESULT FROM ITS USE. SPECIFICATIONS ARE SUBJECT TO CHANGE WITHOUT NOTICE. NO LICENSE, EITHER EXPRESSED OR IMPLIED, IS GRANTED UNDER ANY ADI PATENT RIGHT, COPYRIGHT, MASK WORK RIGHT, OR ANY OTHER ADI INTELLECTUAL PROPERTY RIGHT RELATING TO ANY COMBINATION, MACHINE, OR PROCESS, IN WHICH ADI PRODUCTS OR SERVICES ARE USED. TRADEMARKS AND REGISTERED TRADEMARKS ARE THE PROPERTY OF THEIR RESPECTIVE OWNERS. ALL ANALOG DEVICES PRODUCTS CONTAINED HEREIN ARE SUBJECT TO RELEASE AND AVAILABILITY.