

TABLE OF CONTENTS

Features.....	1	Software Requirements and Installation.....	5
Evaluation Kit Contents.....	1	Installing the SDP-B USB Driver.....	5
Additional Hardware Required.....	1	Installing the ACE GUI with ADMFM2000 Plugin.....	5
Additional Software Required.....	1	ADMFM2000-EVALZ Connection.....	5
General Description.....	1	The Programming Sequence to Set the Mode.....	6
Evaluation Board Photograph.....	1	Evaluation Board Schematics.....	7
Evaluation Board Hardware.....	3	Ordering Information.....	13
Power Supply.....	3	Bill of Materials.....	13
RF Input and IF Output Connections.....	3		
ADMFM2000 Modes of Operation.....	3		
Evaluation Board Software.....	5		

REVISION HISTORY**4/2025—Rev. 0 to Rev. A**

Changes to Additional Software Required Section.....	1
Changes to Evaluation Board Hardware Section.....	3
Changes to Software Requirements and Installation Section.....	5
Changed Installing the ADMFM2000-EVALZ GUI Section to Installing the ACE GUI with ADMFM2000 Plugin Section.....	5
Changes to Installing the ACE GUI with ADMFM2000 Plugin Section.....	5
Replaced Figure 5.....	5
Changes to ADMFM2000-EVALZ Connection Section.....	5
Replaced Figure 6, Figure 7, and Figure 8.....	5
Changes to The Programming Sequence to Set the Mode Section and Table 2.....	6
Moved Figure 8; Renumbered Sequentially.....	6

3/2024—Revision 0: Initial Version

EVALUATION BOARD HARDWARE

The ADMFM2000-EVALZ provides the external components needed to operate the ADMFM2000 in various modes and configurations.

The SDP connector allows the user to communicate with the internal switch and DSA of the ADMFM2000 via a USB port on a Windows®-based PC.

The ADMFM2000-EVALZ requires the use of an SDP-B board along with the ACE GUI software to program the device. The SDP USB driver is available for download at www.analog.com/SDP-B. Follow the steps in the [Installing the ACE GUI with ADMFM2000 Plugin](#) section to install the ACE GUI and the ADMFM2000 plugin.

POWER SUPPLY

The ADMFM2000-EVALZ requires a single 6.0 V DC power supply.

RF INPUT AND IF OUTPUT CONNECTIONS

The ADMFM2000-EVALZ has 11 edge-mounted RF connectors, which are described in [Table 1](#).

ADMFM2000 MODES OF OPERATION

The three operating modes of the ADMFM2000-EVALZ are LNA only, mixer only, or mixer bypass (see [Table 1](#) for further details). In addition, the LNA can be cascaded with the mixer (with an optional attenuation or filtering in between) by making a connection between the BPF IN and BPF OUT connectors. Refer to [Figure 2](#) through [Figure 4](#) for the hardware setup for each mode.

Table 1. Connectors

Mode	Connector(s)	Name(s)	Input or Output	Description
LNA	J2	CH1	Input	Channel 1 RF IN (LNA input)
	J3	CH2	Input	Channel 2 RF IN (LNA input)
	J7	CH1 BPF OUT	Output	Channel 1 LNA output and input to the external band-pass filter (BPF)
	J8	CH2 BPF OUT	Output	Channel LNA output and input to the external BPF
Mixer	J11	CH1 BPF IN	Input	Channel 1 mixer input
	J12	CH2 BPF IN	Input	Channel 2 mixer input
	J4	LO IN	Input	LO input for Channel 1 and Channel 2
Mixer Bypass	J5	CH1 BYPASS IN	Input	Channel 1 mixer bypass input
	J9	CH2 BYPASS IN	Input	Channel 2 mixer bypass input
Mixer and Mixer Bypass	J6	CH1 IF OUT	Output	Channel 1 IF output, mixer, and mixer bypass mode
	J10	CH2 IF OUT	Output	Channel 2 IF output, mixer, and mixer bypass mode

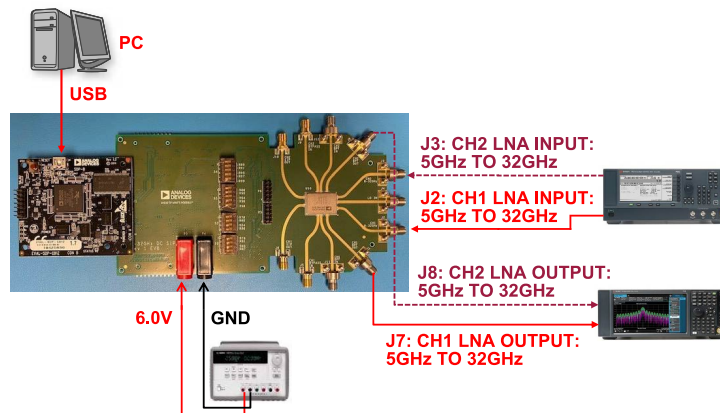

Figure 2. LNA Measurement Setup

EVALUATION BOARD HARDWARE

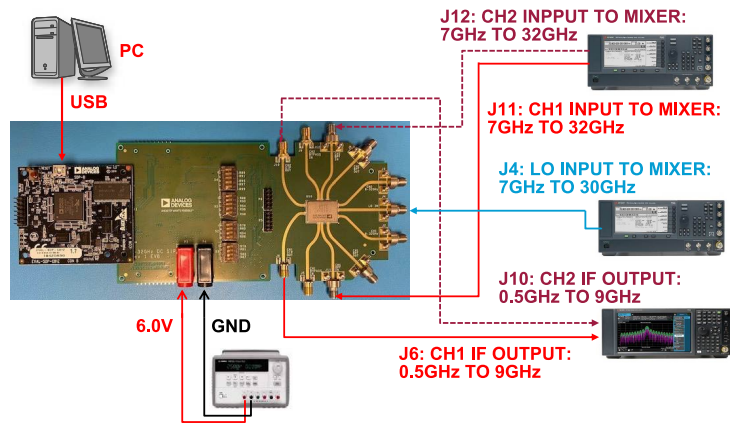

Figure 3. Mixer Measurement Setup

003

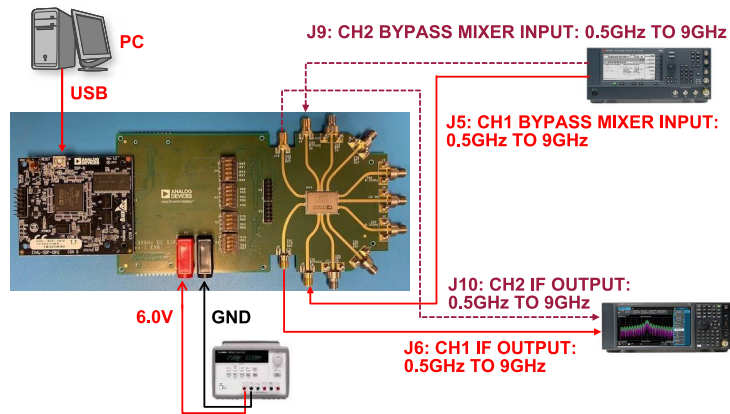

Figure 4. Mixer Bypass Measurement Setup

004

EVALUATION BOARD SOFTWARE

The **ADMFM2000** on the ADMFM2000-EVALZ can be programmed using the **SDP-B** controller board using a USB interface on a standard Windows PC.

SOFTWARE REQUIREMENTS AND INSTALLATION

Connect a Windows-based PC to the USB port of the SDP-B controller board to allow programming of the ADMFM2000-EVALZ using ACE software, which can be downloaded from www.analog.com/ACE.

For additional information on this software, see the [Installing the ACE GUI with ADMFM2000 Plugin](#) section.

INSTALLING THE SDP-B USB DRIVER

To install the SDP USB driver, take the following steps:

1. Download the **SDP USB Driver Installer** from the **SDP-B** product page.
2. Open the downloaded file to begin the installation process. The default installation path is **C:\Program Files\Analog Devices\SDPDriversR2**.

INSTALLING THE ACE GUI WITH ADMFM2000 PLUGIN

To install the ADMFM2000-EVALZ ACE GUI software, take the following steps:

1. Download the software from www.analog.com/ACE.
2. Open the downloaded file to begin the installation process. The default installation path is **C:\Program Files (x86)\Analog Devices\ACE**.
3. Locate the ACE executable file by going to **Start\Analog Devices\ACE** and run this file.

Once the **ACE Software** installation is complete, the **ADMFM2000 ACE Plugin** must be installed. To install this plugin, take the following steps:

1. Open the **ACE Plug-in Manager** window as shown in [Figure 5](#).

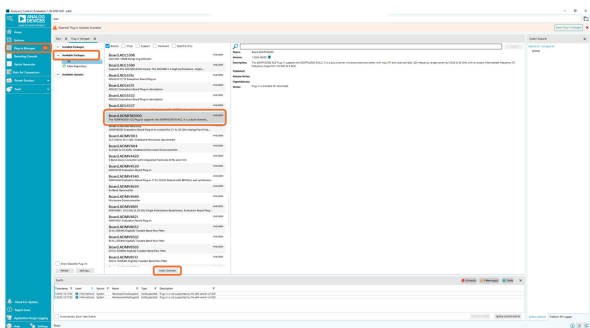

Figure 5. ADMFM2000 ACE Plugin Install

2. Select **Available Packages** in the **Plug-in Manager** window.
3. Find **Board.ADMFM2000** file from the list and select.
4. Click **Install Selected** to install the ADMFM2000 plugin.

ADMFM2000-EVALZ CONNECTION

Take the following steps to connect the ADMFM2000-EVALZ:

1. Set up the test hardware configuration for the desired operating mode, as shown in [Figure 2](#), [Figure 3](#), or [Figure 4](#). Make sure the S1 switch on the secondary side of the ADMFM2000-EVALZ is flipped to the position shown of the S1 silkscreen.
2. Power up the ADMFM2000-EVALZ and connect the USB cable to the PC and to the SDP-B controller board mounted onto the ADMFM2000-EVALZ.
3. Power on the signal generator.
4. Launch the ACE software. If the PC is connected to the SDP-B controller board via the USB cable and the SDP-B controller board is connected to the ADMFM2000-EVALZ board, the **ADMFM2000 Board** is displayed in the **Attached Hardware** area of the ACE software main window (see [Figure 6](#)).

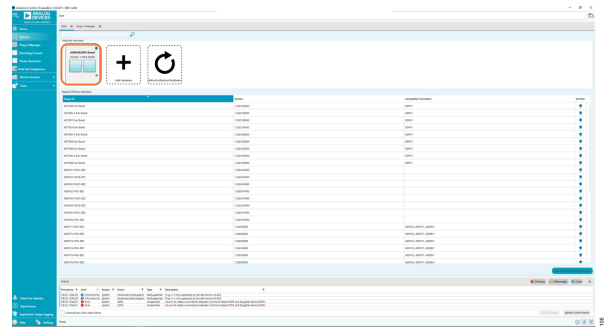

Figure 6. ACE Screen at Startup with the ADMFM200 Board Connected

5. Double-click the **ADMFM2000 Board** icon.
6. The **ADMFM2000 Board** tab then opens with the **ADMFM2000.Chip** plugin icon shown in [Figure 7](#). Double-click the **ADMFM2000.Chip** icon to open the main ADMFM2000 Chip GUI (see [Figure 8](#)).

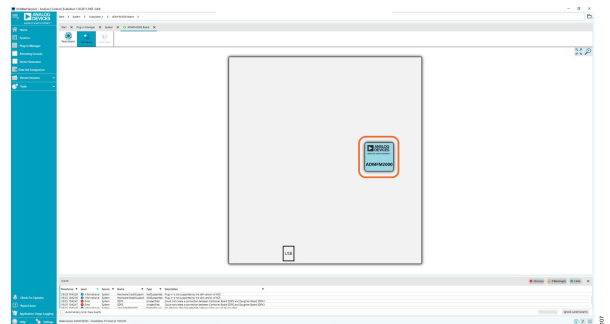

Figure 7. ADMFM2000 Board Plugin

EVALUATION BOARD SOFTWARE

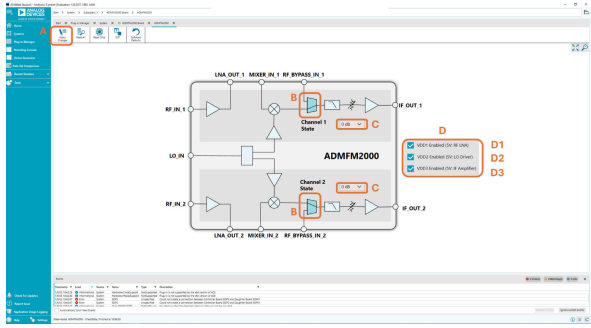

Figure 8. ADMFM2000 Chip Plugin

THE PROGRAMMING SEQUENCE TO SET THE MODE

To set the mode, follow this programming sequence:

1. Run the ADMFM2000-EVALZ ACE GUI software, as explained in the [Installing the ACE GUI with ADMFM2000 Plugin](#) section.
2. Select **MIXER_IN_x** or **RF_BYPASS_IN_x** path with the **Channel State Mux** (Label **B**), adjust the IF attenuation from the dropdown menu in the **Attenuation [dB]** (Label **C**), and **Regulator Controls** (Label **D**), respectively, as shown in [Figure 8](#), if necessary.
3. The updates are applied to the [ADMFM2000](#) after clicking **Apply Changes** (Label **A**) on ADMFM2000 ACE GUI software.

Table 2. ADMFM2000 GUI Block Diagram User Inputs

Label	Function
A	Click Apply Changes to apply the configuration after any changes are made to the Channel State Mux (Label B), Attenuation [dB] (Label C), and Regulator Controls (Label D).
B	The Channel State Mux is where users select between mixer mode and bypass (mixer) mode. The mode must match the hardware setup shown in either Figure 3 and Figure 4 .
C	The Channel x Attenuation [dB] (Label C) dropdown menus allows users to set the DSA attenuation on Channel 1 or Channel 2, respectively.
D	The Regulator Controls allow users to enable or disable VDD1 or VDD2 on the amplifier (LNA, LO driver, and IF amplifier) in the signal path.
D1	The VDD1 Enabled (5V: RF LNA) for both the Channel 1 and Channel 2 enable checkbox.
D2	The VDD2 Enabled (5V: LO Driver) for both the Channel 1 and Channel 2 enable checkbox.
D3	The VDD3 Enabled (5V: IF Amplifier) for both the Channel 1 and Channel 2 enable checkbox.

EVALUATION BOARD SCHEMATICS

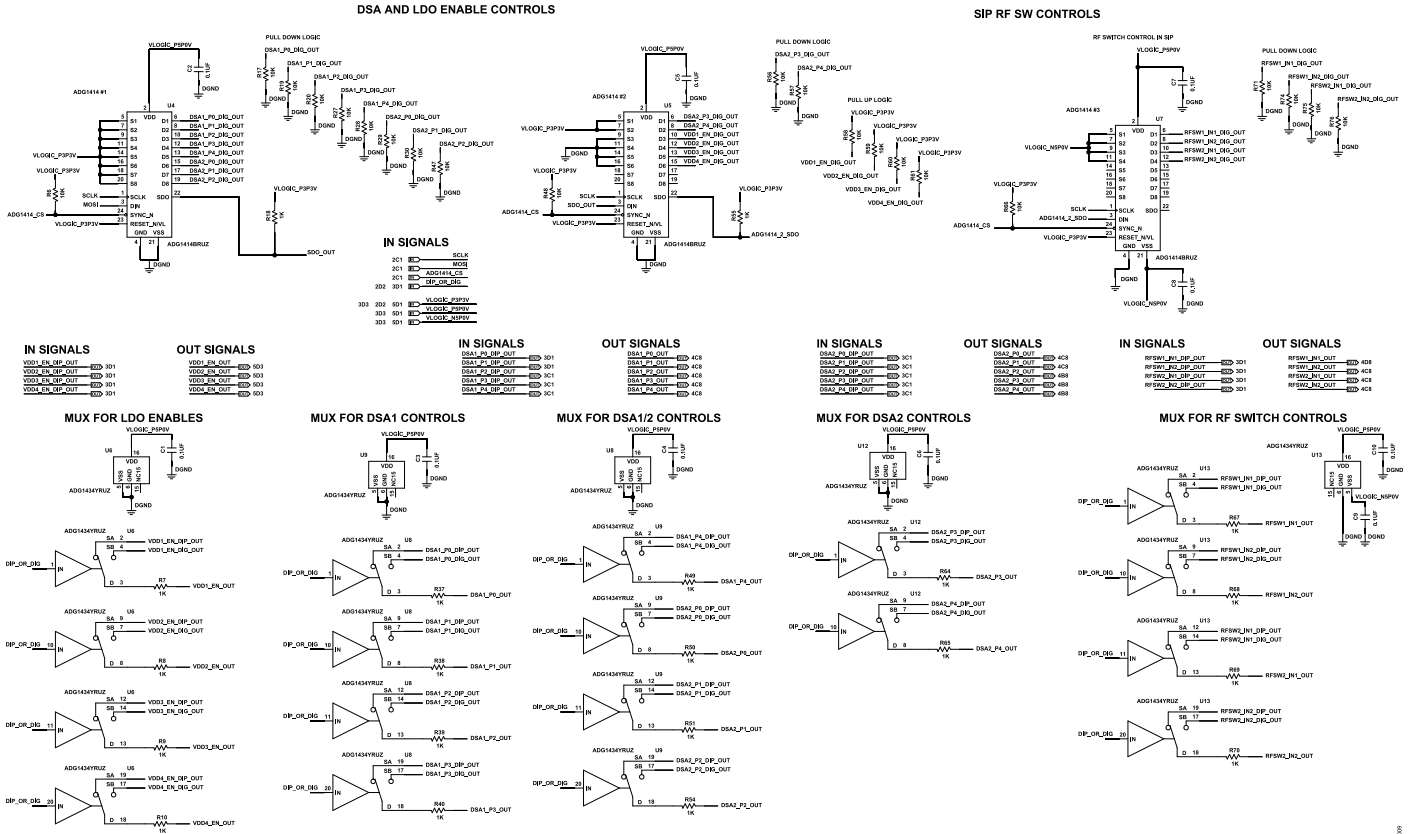

Figure 9. Control Circuit

EVALUATION BOARD SCHEMATICS

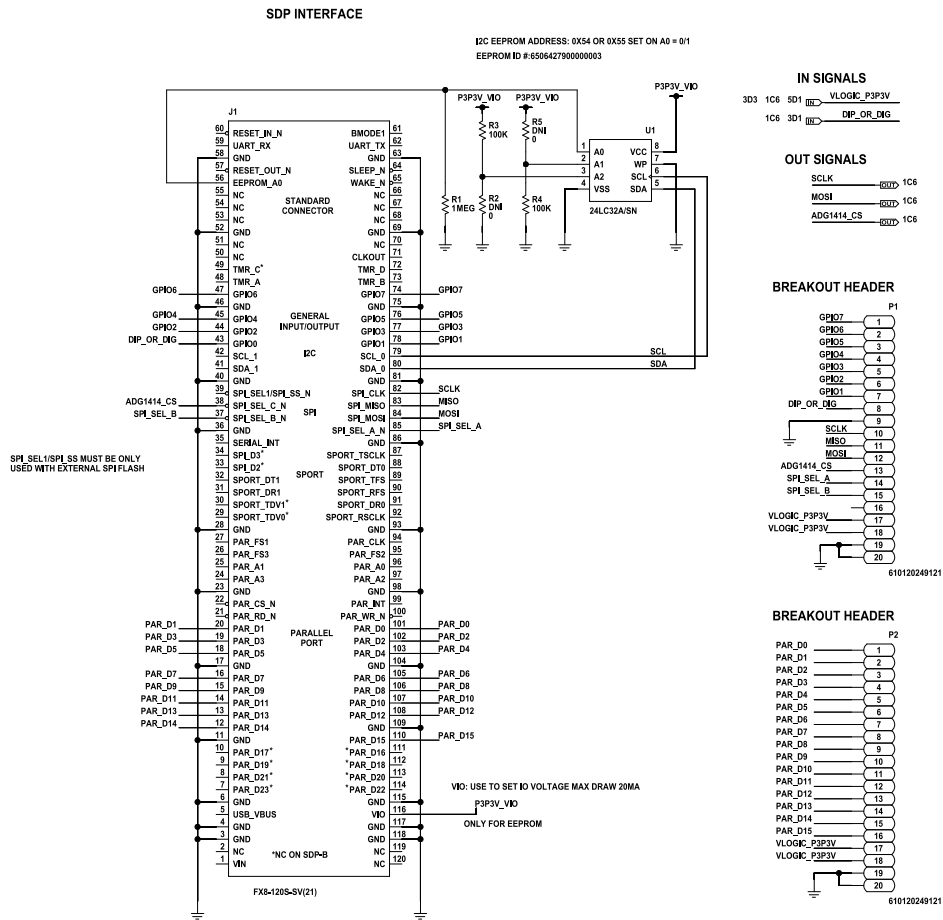

Figure 10. SDP Interface

EVALUATION BOARD SCHEMATICS

DIP SWITCHES

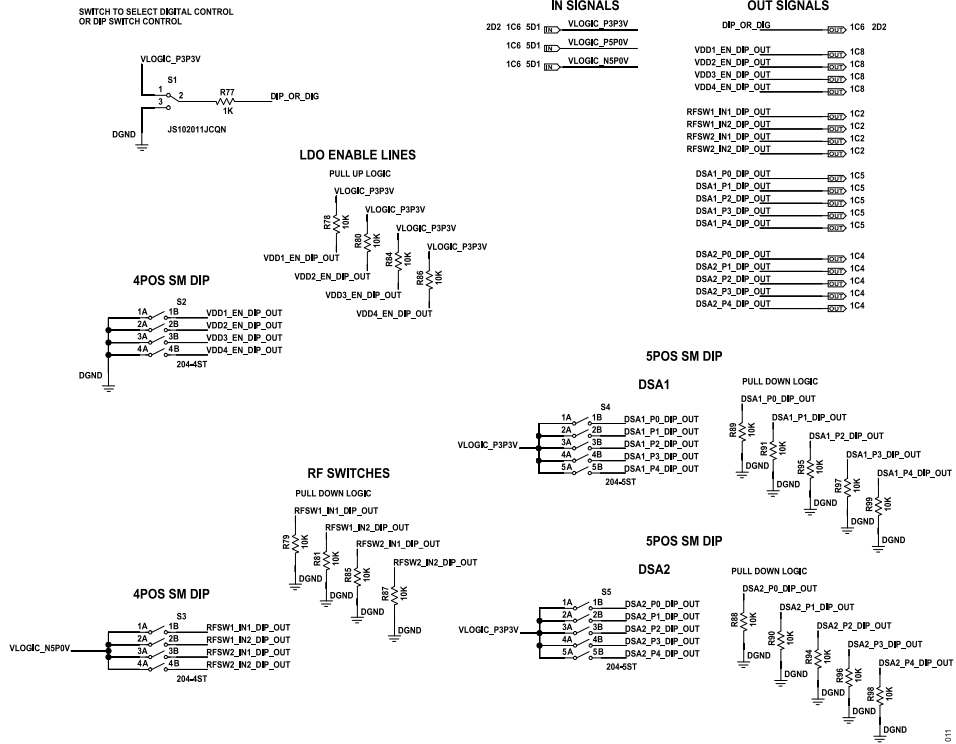

Figure 11. Dual Inline Package (DIP) Switches

EVALUATION BOARD SCHEMATICS

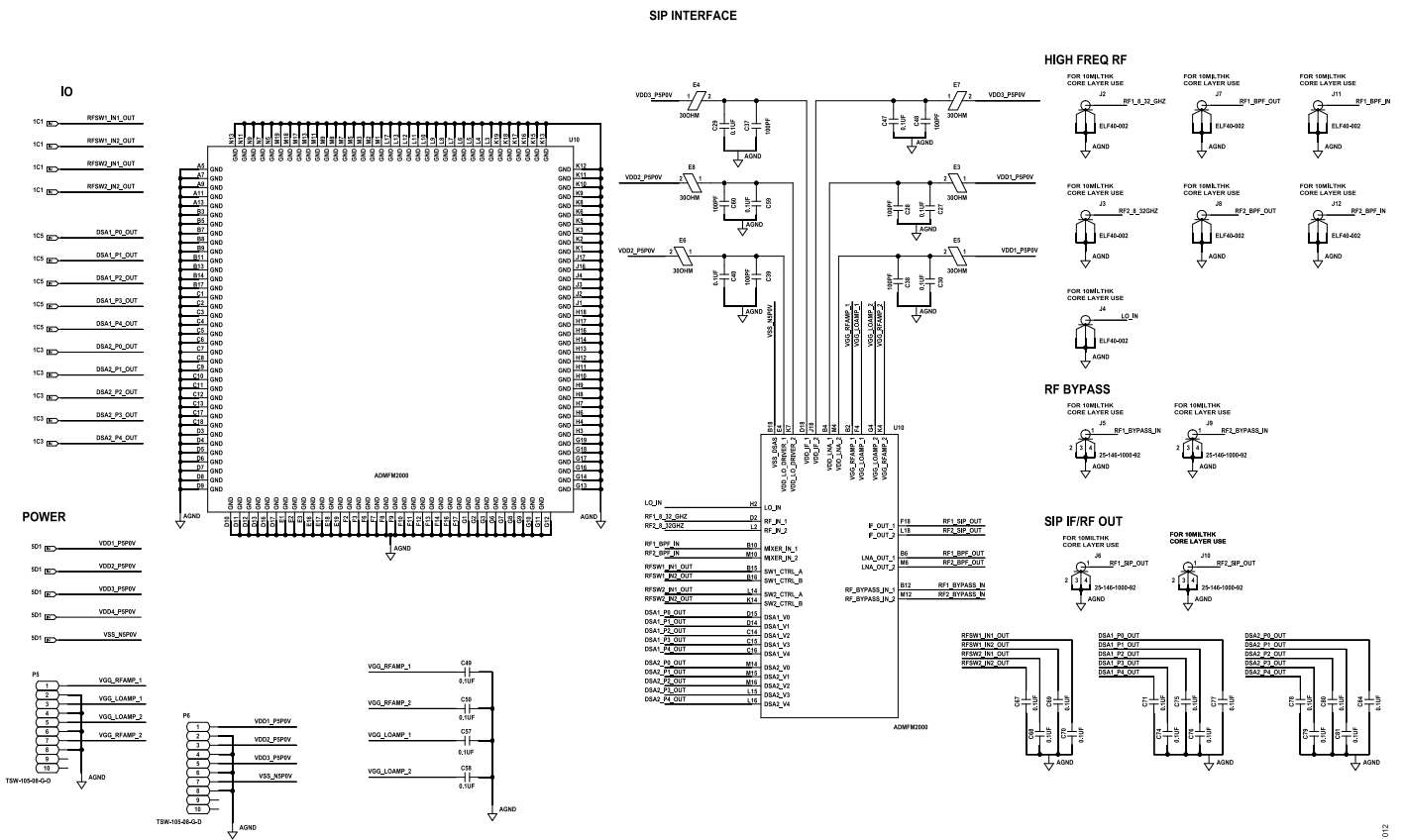

Figure 12. Single Inline Package (SIP) Interface

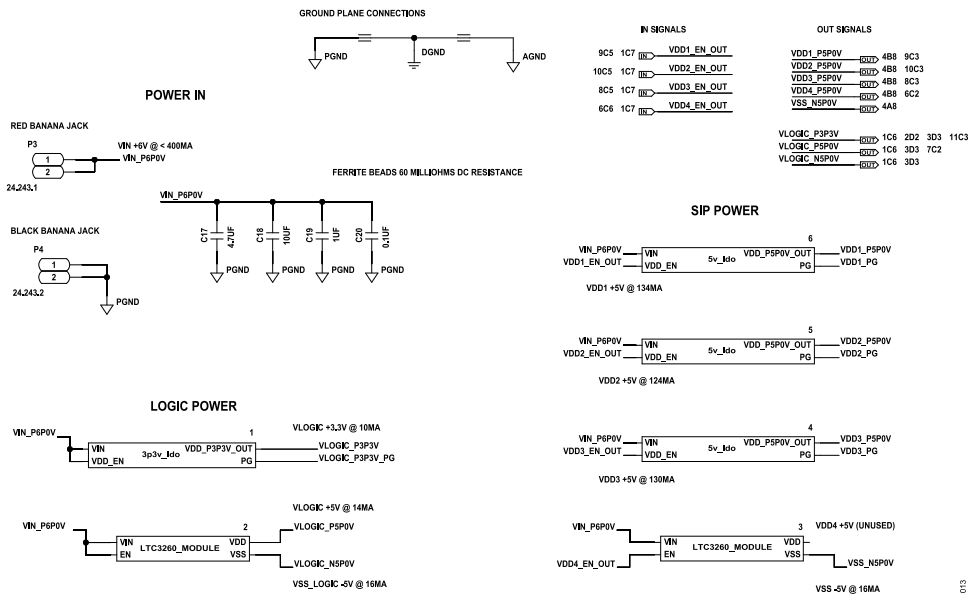

Figure 13. DC Inputs

ORDERING INFORMATION

BILL OF MATERIALS

Table 3. Bill of Materials

Reference Designator	Description	Manufacturer	Part Number
C1 to C10, C20, C27, C29 to C31, C34 to C36, C40, C42, C43, C47, C49, C50, C57 to C59, C61, C64 to C71, C74 to C81, C84, C122, C123, C132, C133	Ceramic capacitors, 0.1 μ F, 25 V, 10%, X5R, 0201	Murata	GRM033R61E104KE14D
C19, C21 to C26, C51, C54 to C56, C102, C103, C112, C113	Ceramic capacitors, 1 μ F, 25 V, 10%, X7R, 0805, AEC-Q200	Murata	GCM21BR71E105KA56L
C11 to C16, C18, C41, C44 to C46, C72, C73, C82, C83, C92, C93	Ceramic capacitors, 10 μ F, 25 V, 10%, X7S, 0805	Murata	GRM21BC71E106KE11L
C17	Ceramic capacitor, 4.7 μ F, 25 V, 10%, X7R, 1206	KEMET	C1206C475K3RACTU
C28, C37 to C39, C48, C60	Ceramic capacitors, 100 pF, 50 V, 5%, C0G, 0201	Murata	GRM0335C1H101JA01D
C32, C33	Ceramic capacitors, 1 μ F, 50 V, 10%, X7R, 1206, AEC-Q200	Murata	GCJ31MR71H105KA12L
C52, C53, C62, C63	Ceramic capacitors, 0.01 μ F, 25 V, 10%, X5R, 0201	Murata	GRM033R61E103KA12D
DS11 to DS16, DS22, DS23	Light emitting diode (LED) chip, ultrabright, 45 mcd, 475 nm, blue	VISHAY	VLMB1500-GS08
E3 to E8, E11 to E16, E22, E23	Ferrite beads, 30 Ω , 0402, 1LN	Murata Manufacturing	BLM15AX300SN1D
J1	Connector for the SDP controller board	HRS	FX8-120S-SV(21)
J5, J6, J9, J10	Connectors, edge launch jack, 38 GHz	SRI Connector Gage Co.	25-146-1000-92
J2 to J4, J7, J8, J11, J12	Connectors, 2.9 mm, end launch, edge-mount jack, 40 GHz	Signal Microwave	ELF40-002
P1, P2	Connectors, breakout headers connected to the SDP interface	Würth Elektronik	610120249121
P3	Connector, banana jack, red for VCC	Multicomp (SPC)	24.243.1
P4	Connector, banana jack, black for GND	Multicomp (SPC)	24.243.2
P5, P6	Connectors (CONN), printed circuit board (PCB), header, straight, 10 position	Samtec	TSW-105-08-G-D
R1	Resistor, surface-mount device (SMD), 1 M Ω , 1%, 1/4 W, 1206	IRC/ITT Electronics	WCR1206-1M0FI
R7 to R10, R18, R32, R33, R37 to R40, R49 to R51, R54, R55, R64, R65, R67 to R70, R77	Resistors, SMD, 1 k Ω , 1%, 1/20 W, 0201	Panasonic	ERJ-1GNF1001C
R42, R43, R100, R1003	Resistors, SMD, 0 Ω , JUMPER, 1/20 W, 0201	Panasonic	ERJ-1GN0R00C
R44 to R46, R102, R103, R112, R113	Resistors, SMD, 470 Ω , 5%, 1/10 W, 0402, AEC-Q200	Panasonic	ERJ-2GEJ471X
R11 to R16, R21, R24 to R26, R31, R34 to R36	Resistors, SMD, 100 k Ω , 1%, 1/20 W, 0201	Panasonic	ERJ-1GNF1003C
R6, R17, R19, R20, R27 to R30, R47, R48, R56 to R61, R66, R71, R74 to R76, R78 to R81, R84 to R91, R94 to R99	Resistors, SMD, 10 k Ω , 5%, 1/20 W, 0201	Panasonic	ERJ-1GNJ103C
R3, R4	Resistors, SMD, 100 k Ω , 1%, 1/16 W, 0603	Multicomp (SPC)	MC 0.063W 0603 1% 100K
R41	Resistor, SMD, 80.6 Ω , 1%, 1/16 W, 0402	Yageo	RC0402FR-0780R6L
R62, R63, R82, R83	Resistors, SMD, 316 k Ω , 1%, 1/20 W, 0201, AEC-Q200	Panasonic	ERJ1GNF3163C
R72, R73, R92, R93	Resistors, SMD, 100 k Ω , 5%, 1/10 W, 0402, AEC-Q200	Panasonic	ERJ-2GEJ104X
R22, R23, R101, R1013	Resistors, SMD, 0 Ω , jumper, 1/20 W, 0201, do not install (DNI)	Panasonic	ERJ-1GN0R00C
R2, R5	Resistors, SMD, 0 Ω , jumper, 1/10 W, 0603, AEC-Q200, DNI	Panasonic	ERJ-3GEY0R00V
R52, R53	Resistors, SMD, 4.99 k Ω , 1%, 1/8 W, 0805, AEC-Q200, DNI	Panasonic	ERJ-6ENF4991V
S1	Digital control select switch, SPDT, where the SPI and general-purpose input and output (GPIO) controls are enabled with the switch on the S1 silkscreen position; otherwise, the optional manual control is effective	C&K	JS102011JCQN

ORDERING INFORMATION

Table 3. Bill of Materials (Continued)

Reference Designator	Description	Manufacturer	Part Number
S2	Switch, SPST, four sections, manual enablement of the on-board voltage regulation circuits ¹	CTS Electronic Components	204-4ST
S3	Switch, SPST, four sections, manual control of the mixer/bypass switch internal to ADMFM2000 ¹	CTS Electronic Components	204-4ST
S4, S5	Switches, SPST, manual DSA controls ¹	CTS Electronic Components	204-5ST
TP11 to TP16, TP21 to TP26, TP32, TP33, TP42, TP43	Test points	Keystone Electronics	5016
U1	IC, 32Kb SERIAL EEPROM, storage for information allowing the SDP system to connect to ADMFM2000	Microchip Technology	24LC32A/SN
U10	Dual-channel, 0.5 GHz to 32 GHz, microwave downconverter	Analog Devices	ADMFM2000
U11	20 V, 300 mA, low noise, CMOS low dropout (LDO) regulator	Analog Devices	ADP7102ACPZ-3.3-R7
U6, U8, U9, U12, U13	4 Ω R_{ON} , quad SPDT, ± 15 V/ ± 12 V/ ± 5 V iCMOS switches	Analog Devices	ADG1434YRUZ
U14 to U16	20 V, 300 mA, low noise, CMOS low dropout (LDO) regulator	Analog Devices	ADP7102ACPZ-5.0-R7
U2, U3	Low noise, dual-supply, inverting charge pump	Analog Devices	LTC3260EMSE#PBF
U4, U5, U7	9.5 Ω R_{ON} , ± 15 V/ ± 12 V/ ± 5 V iCMOS, serially controlled octal SPST switches	Analog Devices	ADG1414BRUZ

¹ Controlling the ADMFM2000 through the GUI is recommended. Manual control is optional. Refer to the [Evaluation Board Schematics](#) section and the [ADMFM2000](#) data sheet for the connection details of each manual switch.

**ESD Caution**

ESD (electrostatic discharge) sensitive device. Charged devices and circuit boards can discharge without detection. Although this product features patented or proprietary protection circuitry, damage may occur on devices subjected to high energy ESD. Therefore, proper ESD precautions should be taken to avoid performance degradation or loss of functionality.

Legal Terms and Conditions

By using the evaluation board discussed herein (together with any tools, components documentation or support materials, the "Evaluation Board"), you are agreeing to be bound by the terms and conditions set forth below ("Agreement") unless you have purchased the Evaluation Board, in which case the Analog Devices Standard Terms and Conditions of Sale shall govern. Do not use the Evaluation Board until you have read and agreed to the Agreement. Your use of the Evaluation Board shall signify your acceptance of the Agreement. This Agreement is made by and between you ("Customer") and Analog Devices, Inc. ("ADI"), with its principal place of business at Subject to the terms and conditions of the Agreement, ADI hereby grants to Customer a free, limited, personal, temporary, non-exclusive, non-sublicensable, non-transferable license to use the Evaluation Board FOR EVALUATION PURPOSES ONLY. Customer understands and agrees that the Evaluation Board is provided for the sole and exclusive purpose referenced above, and agrees not to use the Evaluation Board for any other purpose. Furthermore, the license granted is expressly made subject to the following additional limitations: Customer shall not (i) rent, lease, display, sell, transfer, assign, sublicense, or distribute the Evaluation Board; and (ii) permit any Third Party to access the Evaluation Board. As used herein, the term "Third Party" includes any entity other than ADI, Customer, their employees, affiliates and in-house consultants. The Evaluation Board is NOT sold to Customer; all rights not expressly granted herein, including ownership of the Evaluation Board, are reserved by ADI. CONFIDENTIALITY. This Agreement and the Evaluation Board shall all be considered the confidential and proprietary information of ADI. Customer may not disclose or transfer any portion of the Evaluation Board to any other party for any reason. Upon discontinuation of use of the Evaluation Board or termination of this Agreement, Customer agrees to promptly return the Evaluation Board to ADI. ADDITIONAL RESTRICTIONS. Customer may not disassemble, decompile or reverse engineer chips on the Evaluation Board. Customer shall inform ADI of any occurred damages or any modifications or alterations it makes to the Evaluation Board, including but not limited to soldering or any other activity that affects the material content of the Evaluation Board. Modifications to the Evaluation Board must comply with applicable law, including but not limited to the RoHS Directive. TERMINATION. ADI may terminate this Agreement at any time upon giving written notice to Customer. Customer agrees to return to ADI the Evaluation Board at that time. LIMITATION OF LIABILITY. THE EVALUATION BOARD PROVIDED HEREUNDER IS PROVIDED "AS IS" AND ADI MAKES NO WARRANTIES OR REPRESENTATIONS OF ANY KIND WITH RESPECT TO IT. ADI SPECIFICALLY DISCLAIMS ANY REPRESENTATIONS, ENDORSEMENTS, GUARANTEES, OR WARRANTIES, EXPRESS OR IMPLIED, RELATED TO THE EVALUATION BOARD INCLUDING, BUT NOT LIMITED TO, THE IMPLIED WARRANTY OF MERCHANTABILITY, TITLE, FITNESS FOR A PARTICULAR PURPOSE OR NON-INFRINGEMENT OF INTELLECTUAL PROPERTY RIGHTS. IN NO EVENT WILL ADI AND ITS LICENSORS BE LIABLE FOR ANY INCIDENTAL, SPECIAL, INDIRECT, OR CONSEQUENTIAL DAMAGES RESULTING FROM CUSTOMER'S POSSESSION OR USE OF THE EVALUATION BOARD, INCLUDING BUT NOT LIMITED TO LOST PROFITS, DELAY COSTS, LABOR COSTS OR LOSS OF GOODWILL. ADI'S TOTAL LIABILITY FROM ANY AND ALL CAUSES SHALL BE LIMITED TO THE AMOUNT OF ONE HUNDRED US DOLLARS (\$100.00). EXPORT. Customer agrees that it will not directly or indirectly export the Evaluation Board to another country, and that it will comply with all applicable United States federal laws and regulations relating to exports. GOVERNING LAW. This Agreement shall be governed by and construed in accordance with the substantive laws of the Commonwealth of Massachusetts (excluding conflict of law rules). Any legal action regarding this Agreement will be heard in the state or federal courts having jurisdiction in Suffolk County, Massachusetts, and Customer hereby submits to the personal jurisdiction and venue of such courts. The United Nations Convention on Contracts for the International Sale of Goods shall not apply to this Agreement and is expressly disclaimed. All Analog Devices products contained herein are subject to release and availability.