

## DESCRIPTION

Demonstration circuit 1040 is a quad output regulator consisting of four constant-frequency step-down converters integrated into the LTC3544. DC1040 has an input voltage range of 2.25V to 5.5V, with regulators capable of delivering 100mA, 200mA, 200mA and 300mA of output current. The four regulators operate independently with individual RUN pins and enter pulse skipping mode at low loads to reduce output ripple. In shutdown, the DC1040 draws less than 1 $\mu$ A total. The DC1040 is a very efficient circuit with efficiency greater than 90%. The LTC3544 comes in a 16-pin QFN package, which has an exposed pad on the bottom-side of the IC for better thermal performance. High operating frequency of 2.25MHz allows

exclusive use of small size, low profile surface mount components. These features plus internal compensation circuits make the DC1040 demo board an ideal circuit for use in battery-powered, hand-held applications. The DC1040 design supports both versions of LTC3544: LTC3544EUD (burst mode of operation) and LTC3544BEUD (pulse skip mode of operation). The label on the PCB identifies which controller is installed.

**Design files for this circuit board are available. Call the LTC factory.**

LTC is a trademark of Linear Technology Corporation

**Table 1.** Performance Summary ( $T_A = 25^\circ\text{C}$ )

PARAMETER	CONDITIONS	VALUE
Minimum Input Voltage		2.25V
Maximum Input Voltage		5.5V
Output Voltage Regulation VOUT1	$V_{IN} = 2.25\text{V to } 5.5\text{V}, I_{OUT} = 0\text{A to } 100\text{mA}$	1.2V $\pm$ 2%
Typical Output Ripple VOUT1	$V_{IN} = 5\text{V}, I_{OUT} = 100\text{mA}$ (20 MHz BW)	<15mV <sub>P-P</sub>
Output Voltage Regulation VOUT2	$V_{IN} = 2.25\text{V to } 5.5\text{V}, I_{OUT} = 0\text{A to } 200\text{mA}$	1.5V $\pm$ 2%
Typical Output Ripple VOUT2	$V_{IN} = 5\text{V}, I_{OUT} = 200\text{mA}$ (20 MHz BW)	<15mV <sub>P-P</sub>
Output Voltage Regulation VOUT3	$V_{IN} = 2.25\text{V to } 5.5\text{V}, I_{OUT} = 0\text{A to } 200\text{mA}$	0.8V $\pm$ 2%
Typical Output Ripple VOUT3	$V_{IN} = 5\text{V}, I_{OUT} = 200\text{mA}$ (20 MHz BW)	<15mV <sub>P-P</sub>
Output Voltage Regulation VOUT4	$V_{IN} = 2.25\text{V to } 5.5\text{V}, I_{OUT} = 0\text{A to } 300\text{mA}$	1.8V $\pm$ 2%
Typical Output Ripple VOUT4	$V_{IN} = 5\text{V}, I_{OUT} = 300\text{mA}$ (20 MHz BW)	<15mV <sub>P-P</sub>
Nominal Switching Frequency		2.25 MHz

## QUICK START PROCEDURE

Demonstration Circuit 1040 is easy to set up to evaluate the performance of the LTC3544. For proper measurement equipment configuration, set up the circuit according to the diagram in Figure 1.

NOTE: When measuring the input or output voltage ripple, care must be taken to avoid a long ground lead on the oscilloscope probe. Measure the input or output voltage ripple by touching the probe tip directly across the VIN or VOUT and GND terminals. See the Measurement Equipment Set-up diagram in Figure 2 for proper scope probe technique.

1. Connect the input power supply to the VIN and GND terminals. Connect the loads between the matching VOUT and GND terminals. Refer to Figure 1 for the proper measurement equipment setup. Make sure that loads on outputs VOUT1 through VOUT4 do not exceed 100mA, 200mA, 200mA and 300mA respectively.
2. Apply 5V at VIN and place RUN jumper shunts JP1 through JP4 in the ON positions.
3. Measure all four outputs VOUT1 through VOUT4; they should read 1.2V, 1.5V, 0.8V, 1.8V respectively. All output voltages should be within +/- 2% tolerance.
4. Vary the input voltage from 5.5V to 2.5V, all four output voltages should be within +/- 2% tolerance.
5. Vary the VOUT1 load current from 0 to 100mA,. Each output voltage should be within a tolerance of +/- 2%.
6. Vary the VOUT2 and VOUT3 load currents from 0 to 200mA,. Each output voltage should be within a tolerance of +/- 2%.
7. Vary the VOUT4 load current from 0 to 300mA. Each output voltage should be within a tolerance of +/- 2%.
8. To turn either output off, place corresponding jumper in OFF position.

**Warning** - If the power for the demo board is carried in long leads, the input voltage at the part could “ring”, which could affect the operation of the circuit or even exceed the maximum voltage rating of the IC. To eliminate the ringing, insert a small tantalum capacitor (for instance, AVX part # TAJW686M010) on the pads between the input power and return terminals on the bottom of the demo board. The (greater) ESR of the tantalum will dampen the (possible) ringing voltage due to the use of long input leads. On a normal, typical PCB, with short traces, the capacitor is not needed.

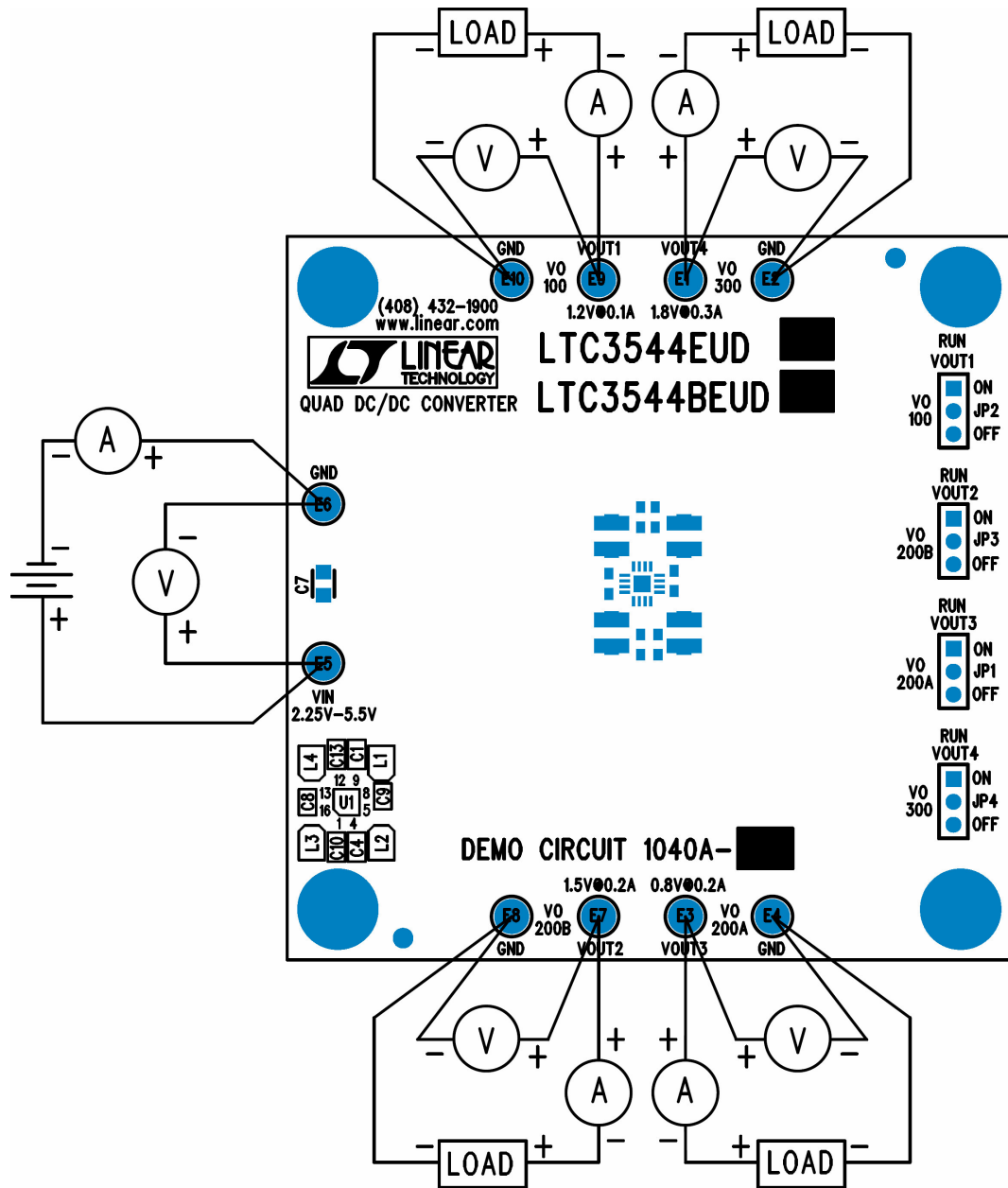

Figure 1. Proper Measurement Equipment Setup

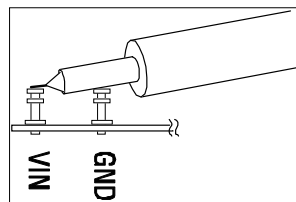
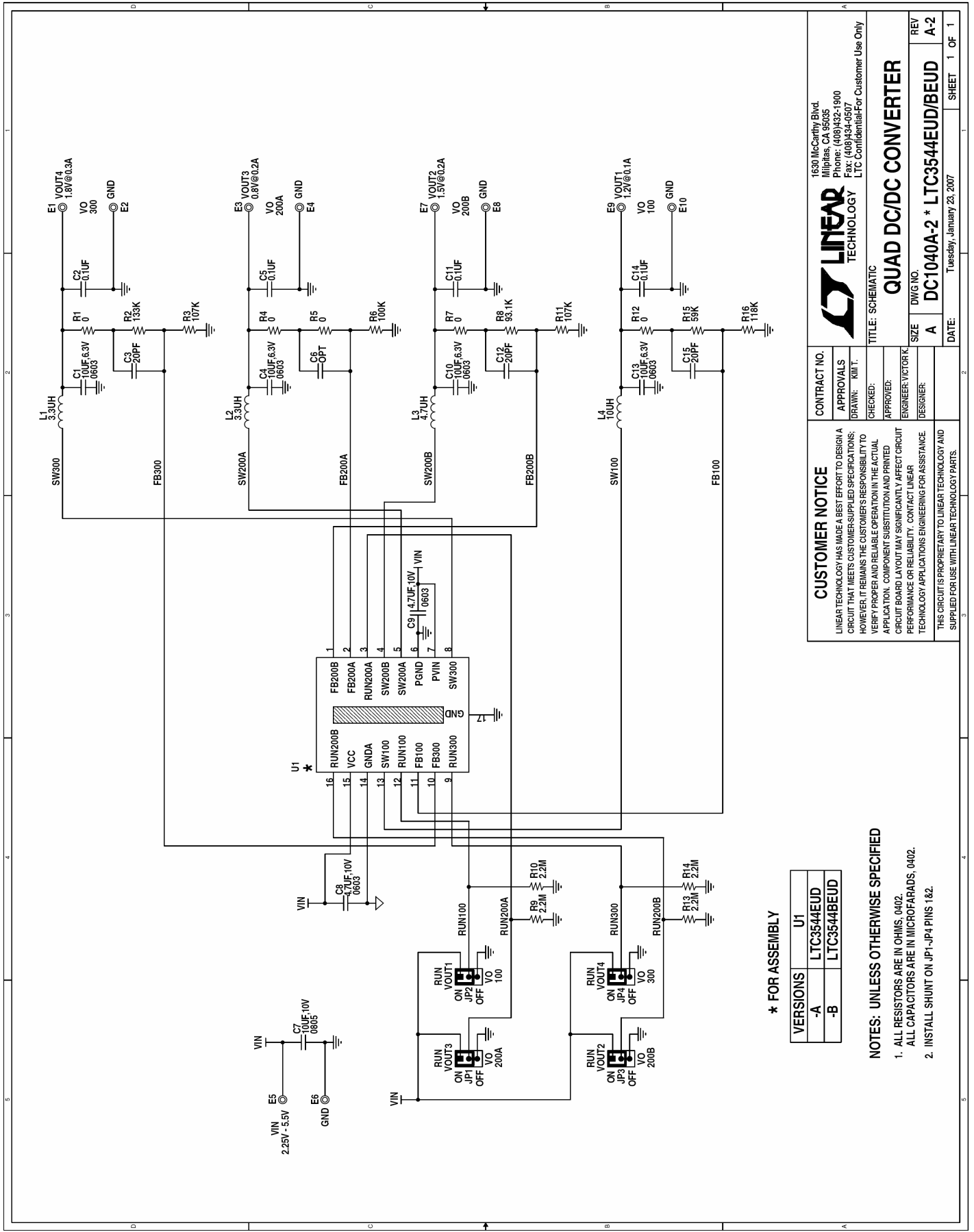

Figure 2. Measuring Input or Output Ripple

# QUICK START GUIDE FOR DEMONSTRATION CIRCUIT 1040

## QUAD DC/DC CONVERTER



**LINEAR TECHNOLOGY**  
 1630 McCarthy Blvd.  
 Milpitas, CA 95035  
 Phone: (408)432-1900  
 Fax: (408)434-9970  
 LTC Confidential-For Customer Use Only

**CONTRACT NO.**  
**APPROVALS**  
**DRAWN:** KIM T.  
**CHECKED:**  
**ENGINEER:** VICTOR K.  
**DESIGNER:**

**CUSTOMER NOTICE**  
 LINEAR TECHNOLOGY HAS MADE A BEST EFFORT TO DESIGN A CIRCUIT THAT MEETS CUSTOMER-SUPPLIED SPECIFICATIONS; HOWEVER, IT REMAINS THE CUSTOMER'S RESPONSIBILITY TO VERIFY PROPER AND RELIABLE OPERATION IN THE ACTUAL APPLICATION. COMPONENT SUBSTITUTION AND PRINTED CIRCUIT BOARD LAYOUT MAY SIGNIFICANTLY AFFECT CIRCUIT PERFORMANCE OR RELIABILITY. CONTACT LINEAR TECHNOLOGY APPLICATIONS ENGINEERING FOR ASSISTANCE. THIS CIRCUIT IS PROPRIETARY TO LINEAR TECHNOLOGY AND SUPPLIED FOR USE WITH LINEAR TECHNOLOGY PARTS.

**TITLE:** SCHEMATIC  
**QUAD DC/DC CONVERTER**

**SIZE:** DWG NO. **A**  
**REV:** **A-2**

**DATE:** Tuesday, January 23, 2007  
**SHEET:** 1 OF 1

\* FOR ASSEMBLY

VERSIONS	U1
-A	LTC3544EUD
-B	LTC3544BEUD

**NOTES: UNLESS OTHERWISE SPECIFIED**

1. ALL RESISTORS ARE IN OHMS, 0402.
2. ALL CAPACITORS ARE IN MICROFARADS, 0402.
3. INSTALL SHUNT ON JP1-JP4 PINS 1&2.