

General Description

The ADuM1252S evaluation kit (EV kit) is a fully assembled and tested circuit board that demonstrates the features of the ADuM1252, a 2-channel bidirectional reinforced digital isolator with ultra-low standby current in an 8-pin narrow SOIC surface-mount package. The ADuM1252S EV kit can be used to evaluate the functionality and electrical performance of the ADuM1252. The EV kit is powered by two independent power supplies.

The ADuM1252S EV kit can also be used to evaluate the ADuM1253, ADuM1254, or ADuM1255

Features and Benefits

- Data Transfer Rates from DC to 2MHz
- Wide Voltage Supply Range from 1.71V to 5.5V
- Convenient Four-Point I²C Bus Connection
- Guaranteed up to 3.0kV_{RMS} Isolation for 60s
- Support Onboard Supply-Current Measurement
- -40°C to +125°C Temperature Range
- Proven PCB Layout
- Fully Assembled and Tested

[Ordering Information](#) appears at end of data sheet.

ADuM1252S EV Kit Photo



Quick Start

Required Equipment

- ADuM1252S EV kit
- Two DC power supplies with an output range of 1.71V to 5.5V
- Signal/function generator (or I²C compatible signals, SDA and SCL)
- Oscilloscope

Procedure

The ADuM1252S EV kit is fully assembled and ready for evaluation. Use the following steps to verify board operation.

1. Verify jumper settings. See [Table 1](#).
2. Connect one DC power supply between the EV kit's VDD1 and AGND1 test points; connect the other DC power supply between VDD2 and AGND2 test points.
3. Set both DC power supply outputs at 3.3V, and then enable the power supply outputs.
4. Connect a signal/function generator (or I²C compatible signals, SDA and SCL) to SDA1 or SCL1 test points and observe the isolated signal on side 2 using an oscilloscope.

Table 1. Jumper Connection Guide

JUMPER	SHUNT POSITION	FEATURE
J1	On*	Pin V _{DD1} is connected to the VDD1 test point.
	Off	Pin V _{DD1} is not powered (for current measurement connections).
J2	On*	Pin V _{DD2} is connected to the VDD2 test point.
	Off	Pin V _{DD2} is not powered (for current measurement connections).
J3	On*	Pin SDA2 is connected to VDD2 with pull-up resistor R3.
	Off	Pin SDA2 is not connected to VDD2.
J4	On*	Pin SCL2 is connected to VDD2 with pull-up resistor R4.
	Off	Pin SCL2 is not connected to VDD2.

*Default options

Considerations for evaluating the ADuM1253, ADuM1254 or ADuM1255

The ADuM1253 and ADuM1255 have a unidirectional clock channel, which only allows a signal flow from SCL1 to SCL2. Therefore, they do not support clock stretching and require that the I²C controller be located on the side 1 bus. For the ADuM1253, all other features and parameters are similar to the ADuM1252.

The ADuM1254's features and parameters are similar to the ADuM1252, with the primary difference that the ADuM1254 offers a lower level of guaranteed performance. The ADuM1255 is the unidirectional clock variant of the ADuM1254. Hence, it comes with a similarly lower guaranteed performance compared to the ADuM1252 (or ADuM1253).

The ADuM1253 or ADuM1255 may be substituted for the installed ADuM1252 when the unidirectional clock is to be evaluated.

Detailed Description of Hardware

The ADuM1252S EV kit evaluates the features of the ADuM1252, 2-channel bidirectional galvanic digital isolators in an 8-pin narrow SOIC package for I²C applications. The EV kit is powered by two individual power supplies from 1.7V to 5.5V.

Jumper Connection

Jumpers J1 and J2 are provided for easy current meter connections. To measure the supply current from either side 1 or side 2, remove the shunt on the jumper and connect a current meter to the respective jumper directly.

Jumpers J3 and J4 give users options for current measurement or disconnecting SDA2 and SCL2 pins from on-board pull-up resistors R3 and R4. To verify the Hot Swap precharged voltage on pins SDA2 and SCL2, be sure no shunt on J3 and J4.

The ADuM1252S EV kit allows multi access for signal connections, see [Table 2](#). Jumper J9 provides a

convenient location for a four-point I²C bus connection allowing the EV kit to communicate with an I²C bus with either twisted wire or a 4-pin header.

Decoupling Capacitor

Each power supply is decoupled with 0.1μF and 1000pF ceramic capacitors, which are placed close to V_{DD1} and V_{DD2} pins.

Pullups

SDA₁ and SCL₁ are connected to its corresponding V_{DD₁} with a 1kΩ pull-up resistor. The EV kit is optimal at 3.3V operation. The user can change the pull-up resistors for different supply voltages.

Output Load

Each SDA₁ and SCL₁ signal trace is provided with unpopulated 0805 case surface mount footprints (C7 to C10) to allow different loads on customer requirements.

Table 2. Signal Connections

SIDE 1		SIDE 2 (I ² C BUS SIDE)	
SDA1	test point SDA1	SDA2	test point SDA2
	J5 pins 2 and 3		J7 pins 2 and 3
SCL1	test point SCL1		SCL2
	J6 pins 2 and 3	test point SCL2	
			J9 pin 2

Ordering Information

PART NUMBER	TEMP RANGE
ADuM1252SEVKIT#	EV KIT

#Denotes RoHS compliance.

ADuM1252S EV Kit Bill of Materials

REFERENCE DESIGNATOR	QTY	DESCRIPTION	MANUFACTURER	PART NUMBER
AGND1(3x), AGND2(2x), SCL1, SCL2, SDA1, SDA2, VDD1, VDD2	11	SMT test point	Keystone	5017
C1, C2	2	10 μ F \pm 10%, 16V X7R ceramic capacitor (0805)	Samsung Murata CAL-CHIP	CL21B106KOQNNN GRM21BZ71C106KE15 GMC21X7R106K16NT
C3, C4	2	0.1 μ F \pm 10%, 25V X7R ceramic capacitor (0603)	TDK KEMET AVX	C1608X7R1E104K080AA, C0603C104K3RAC 06033C104KAT2A
C5, C6	2	1000pF \pm 5%, 50V C0G ceramic capacitor (0402)	Murata TDK	GRM1555C1H102JA01 C1005C0G1H102J050
C7, C8	DNI	20 pF \pm 5%, 100V C0G ceramic capacitor (0805)	N/A	N/A
C9, C10	DNI	390 pF \pm 5%, 100V C0G ceramic capacitor (0805)	N/A	N/A
J1-J4	4	2-pin header, straight through hole male connector	Sullins	PCC02SAAN
J5-J8	4	3-pin header, straight through hole male connector	Sullins	PCC03SAAN
J9	DNI	4-pin header, straight through hole male connector	N/A	N/A
R1-R4	4	1k Ω \pm 1%, 1/8 W thick film chip resistor (0805)	Vishay Dale Panasonic	CRCW08051K00FK ERJ-6ENF1001
U1	1	ADuM1252 (8-pin Narrow SOIC)	Analog Device Inc.	ADuM1252ASA+
None	1	ADuM1252S EV kit Rev A board	N/A	N/A
None	4	Round through hole spacer	Keystone	9032
None	4	Shunt	Samtec Inc.	SNT-100-BK-G

ADuM1252S EV Kit Schematic Diagram

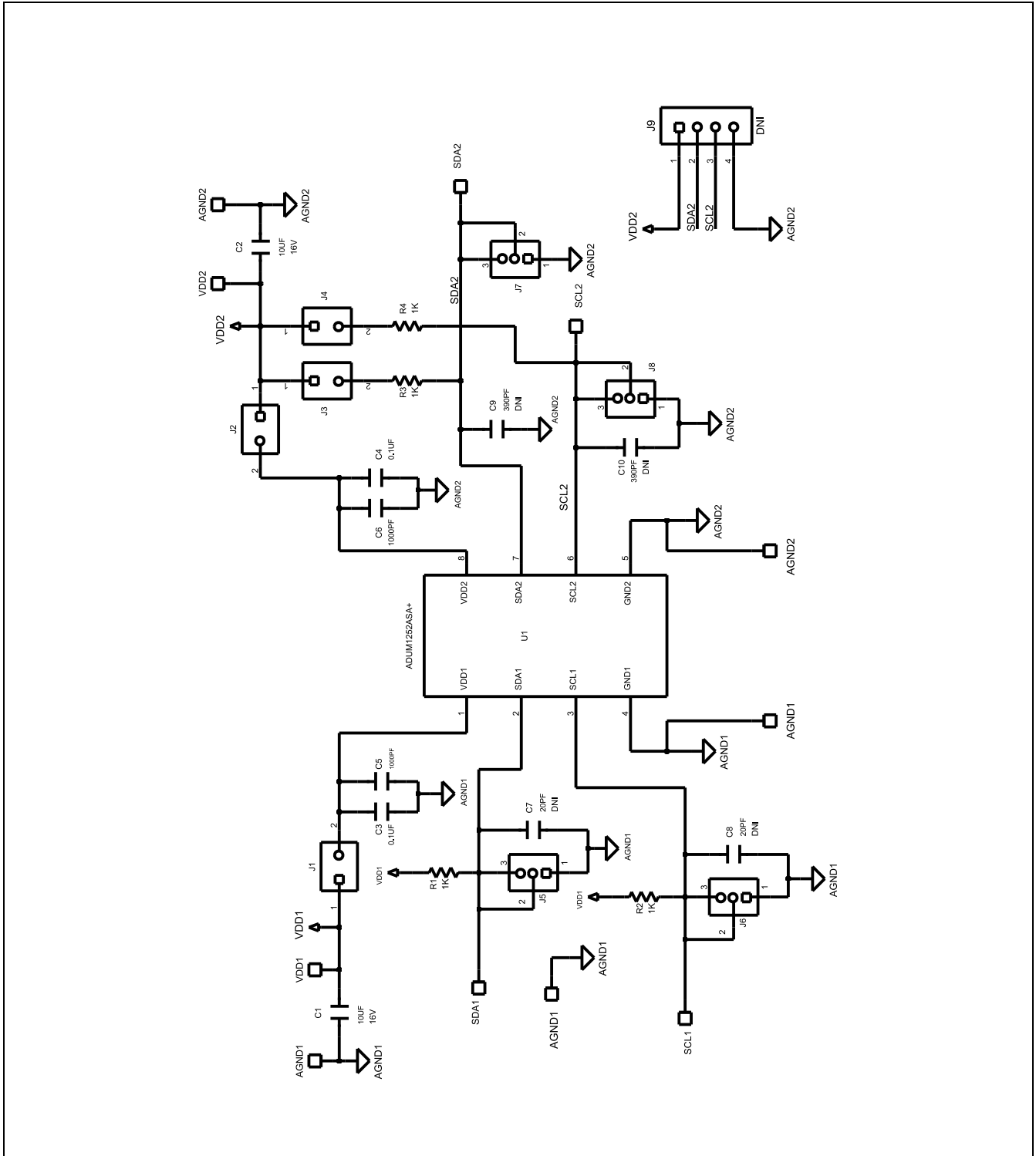

ADuM1252S Evaluation Kit

Evaluates: ADuM1252, ADuM1253, ADuM1254, ADuM1255

ADuM1252S EV Kit PCB Layout

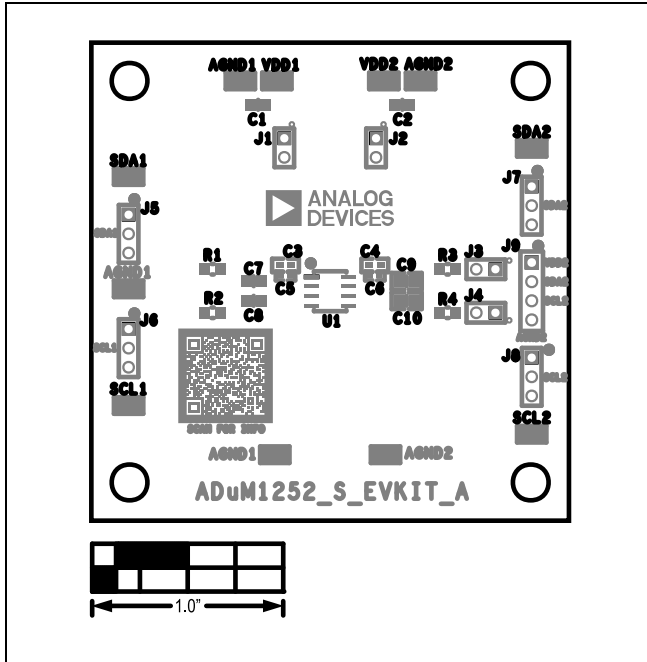

ADuM1252S EV Kit Component Placement Guide—Top Silkscreen

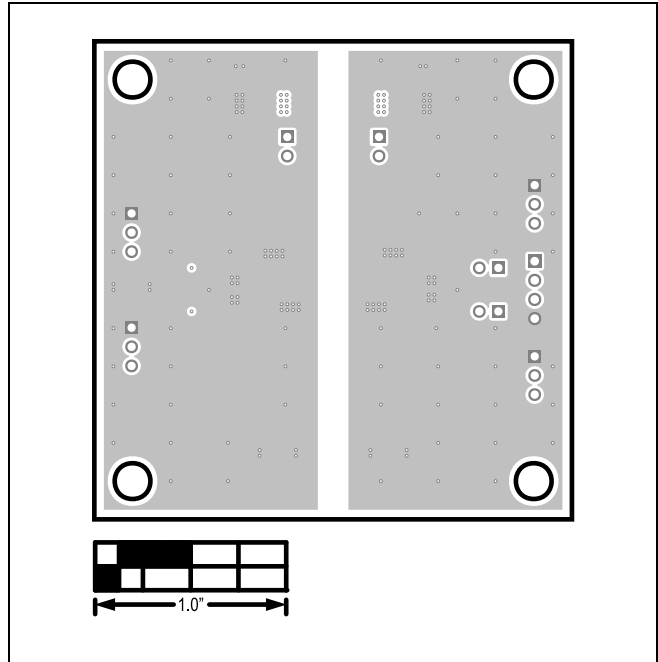

ADuM1252S EV Kit PCB Layout—Layer 2 (GND_Layer)

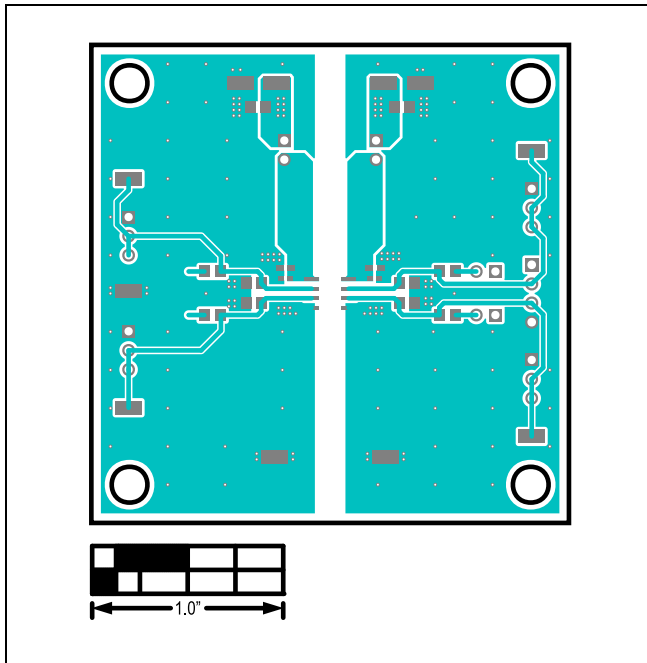

ADuM1252S EV Kit PCB Layout—Top View

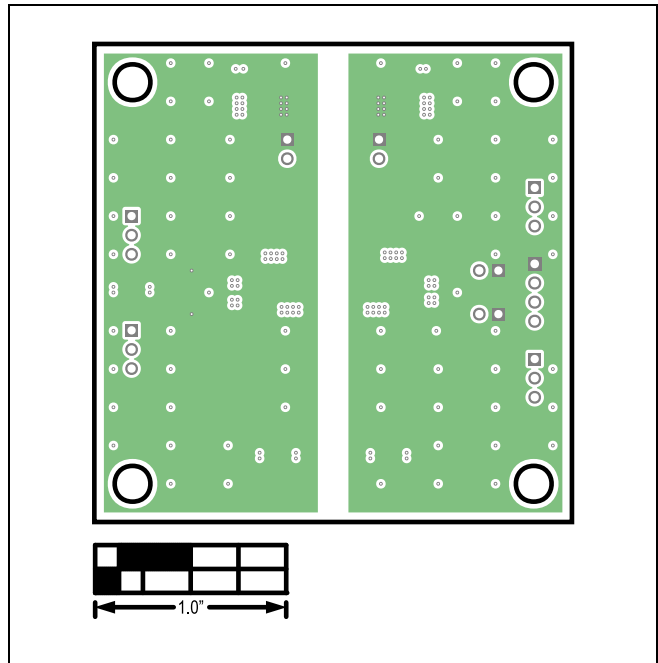

ADuM1252S EV Kit PCB Layout—Layer 3 (VDD_Layer)

ADuM1252S EV Kit PCB Layout (continued)

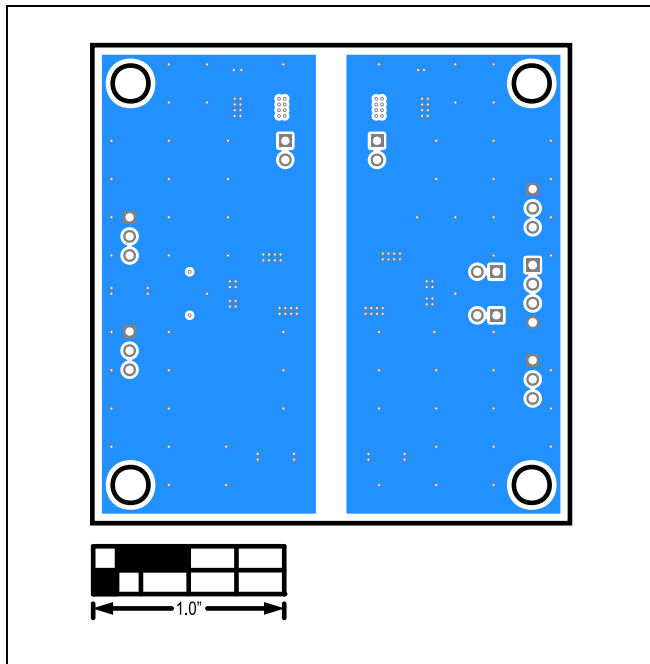

ADuM1252S EV Kit PCB Layout—Bottom View

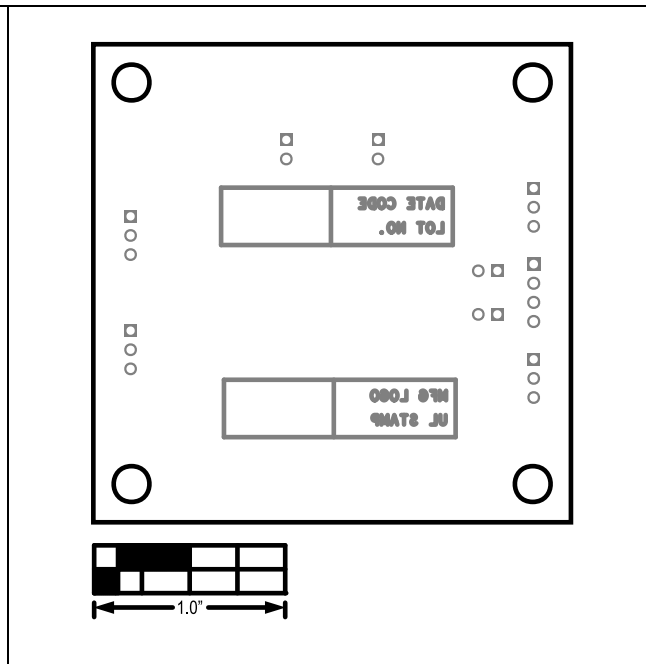

ADuM1252S EV Kit PCB Layout—Bottom Silkscreen

Revision History

REVISION NUMBER	REVISION DATE	DESCRIPTION	PAGES CHANGED
0	06/23	Initial release	—
A	09/23	Added new part numbers and updated the <i>Quick Start</i> section	1–8
B	01/24	Added new part numbers and updated the <i>Quick Start</i> section	1–8

