

## Evaluating the **ADP5138** Quad 1 A, 5.5 V, Synchronous Step-Down Regulators with One RF LDO Regulator

### FEATURES

- Full featured evaluation board for the **ADP5138**
- Compact solution size
- 4-layer high glass transition temperature PCB for superior thermal performance
- Connections through vertical printed circuit tail pin headers
- Supply voltage
  - 3 V to 5.5 V (5 V typical) for PVINx
- Fixed or adjustable output options for quad 1 A buck regulators and one 250 mA RF LDO regulator
- Independent enable control for each regulator
- Power-on reset output

### APPLICATIONS

- Full evaluation of **ADP5138**

### EVALUATION KIT CONTENTS

- ADP5138W-1-EVALZ evaluation board

### DOCUMENT NEEDED

- ADP5138** data sheet

### EQUIPMENT NEEDED

- DC power supply
- Electronic load
- Oscilloscope

### GENERAL DESCRIPTION

The ADP5138W-1-EVALZ evaluation board provides a complete and compact solution that allows users to evaluate the performance of the **ADP5138** with a near ideal printed circuit board (PCB) layout.

The main device on the evaluation board, the **ADP5138**, integrates four high performance synchronous step-down regulators and one low noise radio frequency (RF) low dropout (LDO) regulator.

The ADP5138W-1-EVALZ has independent enable controls for each regulator that allow flexible configuration when evaluating the **ADP5138**.

Full details on the **ADP5138** regulator are provided in the **ADP5138** data sheet, available from Analog Devices, Inc. Consult the data sheet in conjunction with this user guide when working with the ADP5138W-1-EVALZ.

### EVALUATION BOARD PHOTOGRAPH

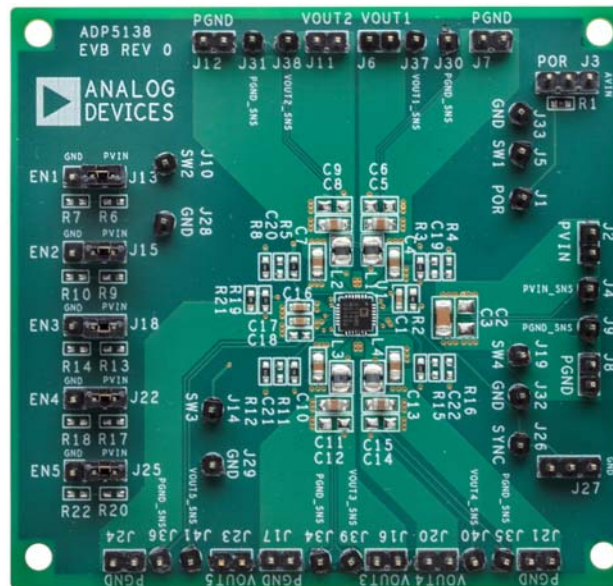

Figure 1.

**TABLE OF CONTENTS**

Features .....	1	Powering Up.....	3
Applications.....	1	Measuring Evaluation Board Performance .....	3
Evaluation Kit Contents.....	1	Evaluation Board Schematics and Artwork.....	5
Document Needed.....	1	Schematic.....	5
Equipment Needed.....	1	PCB Layout .....	6
General Description .....	1	Ordering Information.....	7
Evaluation Board Photograph.....	1	Bill of Materials.....	7
Revision History .....	2		
Using the Evaluation Board.....	3		

**REVISION HISTORY**

5/2018—Revision 0: Initial Version

## USING THE EVALUATION BOARD

### POWERING UP

The ADP5138W-1-EVALZ evaluation board is supplied fully assembled and tested. Before applying power to the ADP5138W-1-EVALZ follow the procedures in this section.

#### **Jumper J13 (EN1)**

To enable Buck 1, short the middle pin of J13 (EN1) to PVIN. PVIN is the shared PVINx pin supply (see Figure 3).

To disable Buck 1, short the middle pin of J13 (EN1) to GND.

#### **Jumper J15 (EN2)**

To enable Buck 2, short the middle pin of J15 (EN2) to PVIN.

To disable Buck 2, short the middle pin of J15 (EN2) to GND.

#### **Jumper J18 (EN3)**

To enable Buck 3, short the middle pin of J18 (EN3) to PVIN.

To disable Buck 3, short the middle pin of J18 (EN3) to GND.

#### **Jumper J22 (EN4)**

To enable the Buck 4, short the middle pin of J22 (EN4) to PVIN.

To disable the Buck 4, short the middle pin of J22 (EN4) to GND.

#### **Jumper J25 (EN5)**

To enable the LDO, short the middle pin of J25 (EN5) to PVIN.

To disable the LDO, short the middle pin of J25 (EN5) to GND.

### Input Power Source

If the input dc power source includes a current meter, use that meter to monitor the input current. Connect the positive terminal of the power source to J2 (PVIN) of the evaluation board, and the negative terminal of the power source to J8 (PGND) of the evaluation board.

If the dc power source does not include a current meter, connect a current meter in series with the input source voltage. Connect the positive lead (+) of the power source to the positive (+) ammeter terminal, the negative lead (–) of the power source to J8 (PGND), and the negative lead (–) of the ammeter to J2 (PVIN).

### Output Load

Before connecting the load, ensure all the regulators are turned off. Connect an electronic load or resistor for each regulator to set the load current.

Using Buck 1 as an example, connect the positive terminal of the load to J6 (VOUT1) of the evaluation board and connect the negative terminal of the load to J7 (PGND).

### Input and Output Voltmeter

Measure the input and output voltages using voltmeters. Ensure the voltmeters are connected to the appropriate terminals of the evaluation board and not to the load or power source. If the voltmeters are not connected directly to the evaluation board, the measured voltages are incorrect due to the voltage drop across the leads and/or connections between the evaluation board, the power source, and/or the load.

To measure the input voltage, connect the positive terminal of the voltmeter to J4 (PVIN\_SNS) and the negative terminal to J9 (PGND\_SNS). To measure the output voltage of Buck 1, connect the positive terminal of the voltmeter to J37 (VOUT1\_SNS) and the negative terminal to J30 (PGND\_SNS). The measurement method of the output voltage for the other regulators is the same as for Buck 1.

### Turning On the Evaluation Board

When the power source and load are connected to the ADP5138W-1-EVALZ, it can be powered for operation.

Take the following steps to turn on the ADP5138W-1-EVALZ evaluation board:

1. Set the input voltage to 5 V.
2. Ensure ENx of the channel to be enabled is high, and monitor the output voltage.
3. Turn on the load, and check that it is drawing the load current that was set, and verify that the output voltage maintains its regulation.

## MEASURING EVALUATION BOARD PERFORMANCE

### Measuring the Switching Waveform

To observe the switching waveform with an oscilloscope, place the oscilloscope probe tip at Test Point J5 (SW1), J10 (SW2), J14 (SW3), and J19 (SW4) with the probe ground at J33 (GND), J28 (GND), J29 (GND), and J32 (GND), respectively. Set the scope to dc with the appropriate voltage and time divisions. The switching waveform limits alternate approximately between 0 V and the input voltage.

### Measuring Load Regulation

Test the load regulation by observing the change in each output voltage when increasing each output load current. To minimize the voltage drop, use short, low resistance wires.

### Measuring Line Regulation

Vary the input voltage and examine the change in each output voltage with the fixed output current.

### Line Transient Response

Generate a step input voltage change and observe the behavior of each output voltage using an oscilloscope.

### Load Transient Response

Generate a load current transient at each output and observe the output voltage response using an oscilloscope. Attach the current probe to the wire between the output and the load to capture the current transient waveform.

### Measuring Efficiency

The efficiency,  $\eta$ , is measured by comparing the input power with the output power.

Measure the input and output voltages as close as possible to the input and output capacitors to reduce the effect of voltage drop.

To measure the efficiency of one specific regulator, enable this regulator only and disable the other regulators. The efficiency of the enabled regulator is as follows:

$$\eta_x = \frac{V_{OUTx} \times I_{OUTx}}{V_{IN} \times I_{IN}}$$

To measure the overall efficiency, enable all regulators. To calculate the overall efficiency, see Equation 1.

$$\eta = \frac{V_{OUT1} \times I_{OUT1} + V_{OUT2} \times I_{OUT2} + V_{OUT3} \times I_{OUT3} + V_{OUT4} \times I_{OUT4} + V_{OUT5} \times I_{OUT5}}{V_{IN} \times I_{IN}} \quad (1)$$

### Measuring Inductor Current

Measure the inductor current by removing one end of the inductor from its pad and connecting a current loop in series. A current probe can be connected onto this wire.

### Measuring Output Voltage Ripple

To observe the output voltage ripple, place the oscilloscope probe across the output capacitor with the probe ground lead connected to the negative (–) capacitor terminal and the probe tip placed at

the positive (+) capacitor terminal. Set the oscilloscope to ac, 10 mV/division, 2  $\mu$ s/division time base, and 20 MHz bandwidth.

A standard oscilloscope probe has a long wire ground clip. For high frequency measurements, this ground clip picks up high frequency noise and injects it into the measured output ripple. Figure 2 shows an easy way to measure the output voltage ripple properly. Remove the oscilloscope probe sheath and wrap an unshielded wire around the oscilloscope probe. By keeping the ground length of the oscilloscope probe as short as possible, the true ripple can be measured.

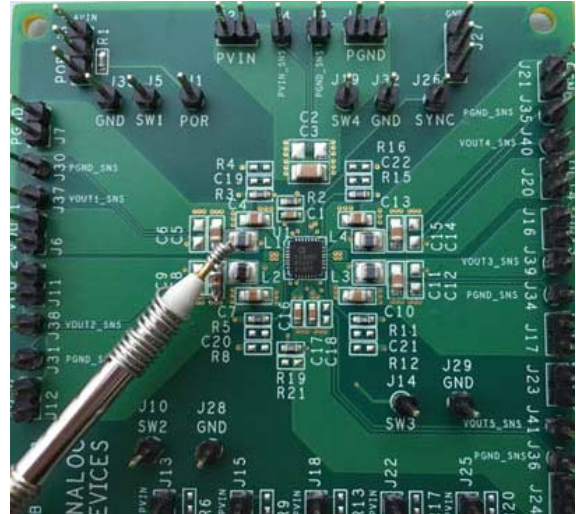
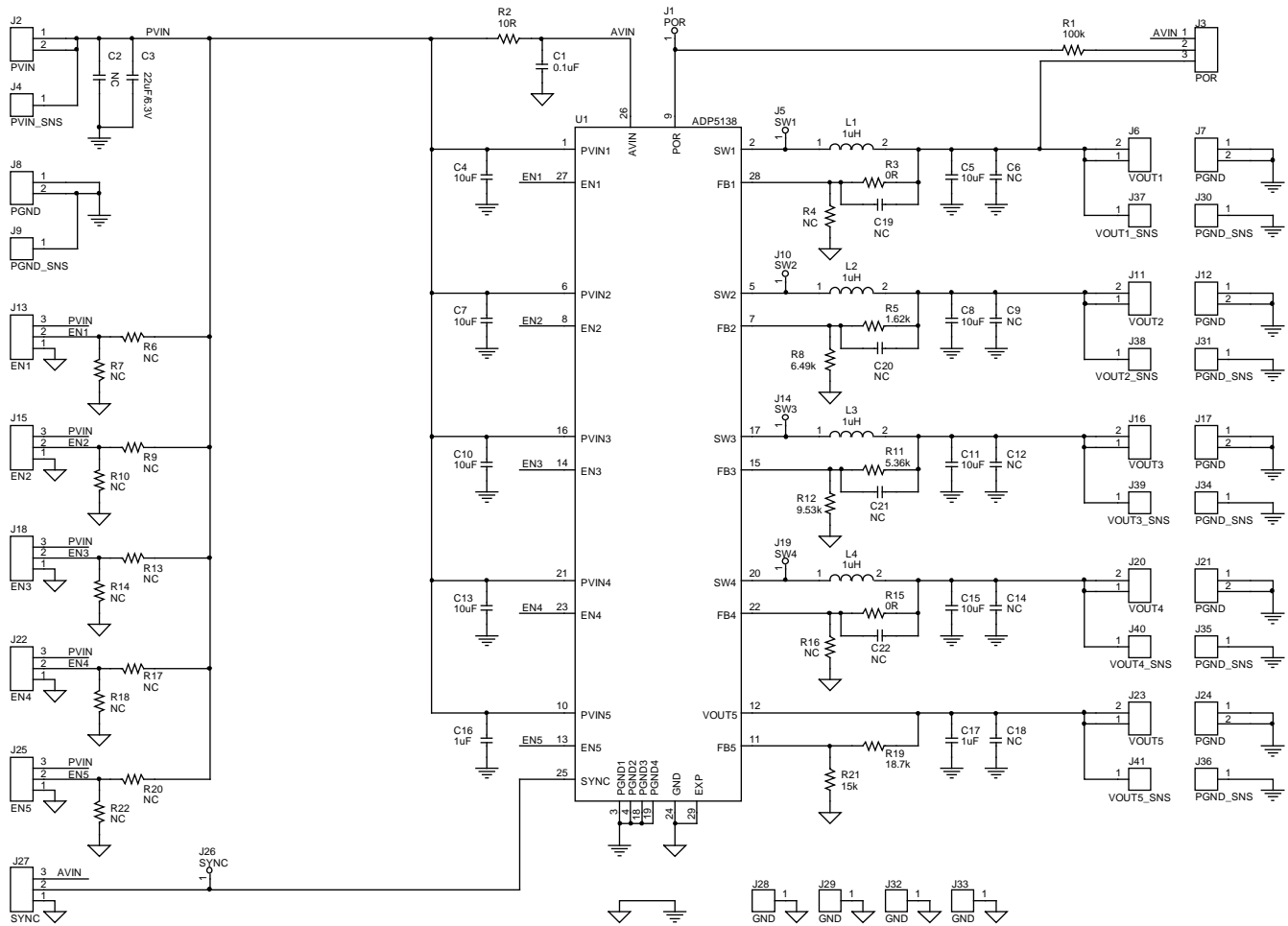

Figure 2. Measuring Output Voltage Ripple

# EVALUATION BOARD SCHEMATIC AND ARTWORK

## SCHEMATIC



VOUT1 = 3.3V, VOUT2 = 1.0V, VOUT3 = 1.25V, VOUT4 = 1.35V, VOUT5 = 1.8V

Figure 3. Evaluation Board Schematic for the ADP5138W-1-EVALZ

16697-003

PCB LAYOUT

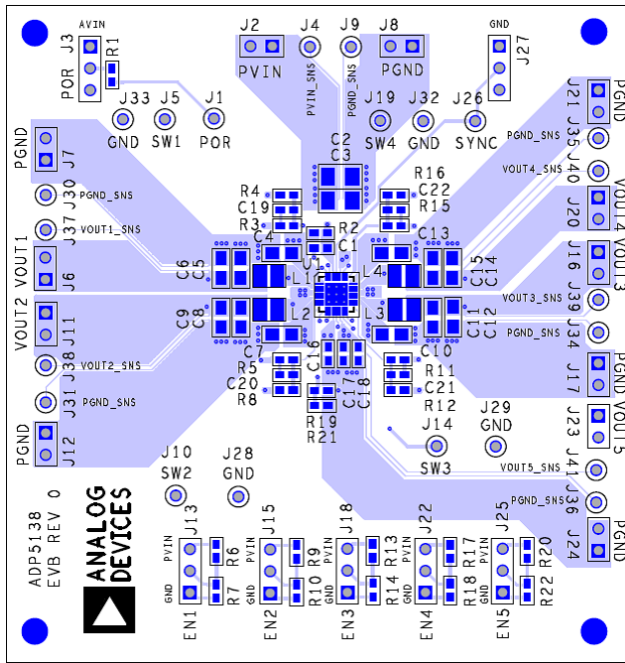

Figure 4. Layer 1, Component Side

16697-004

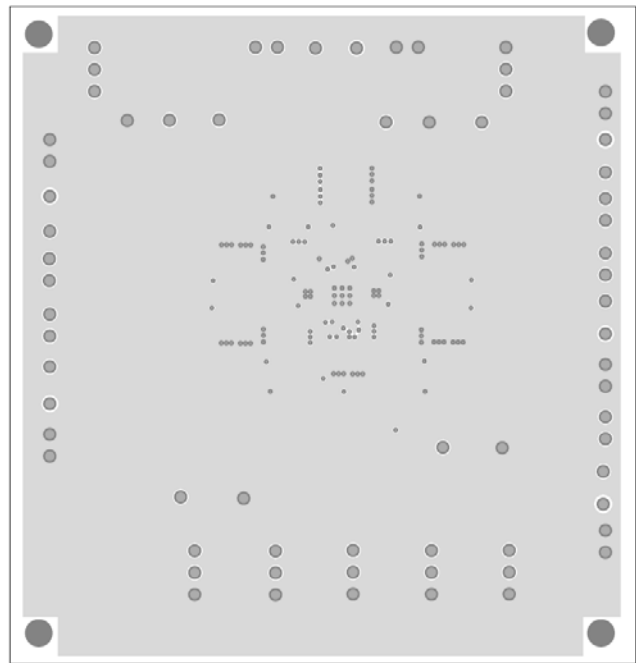

Figure 6. Layer 2, Ground Plane

16697-006

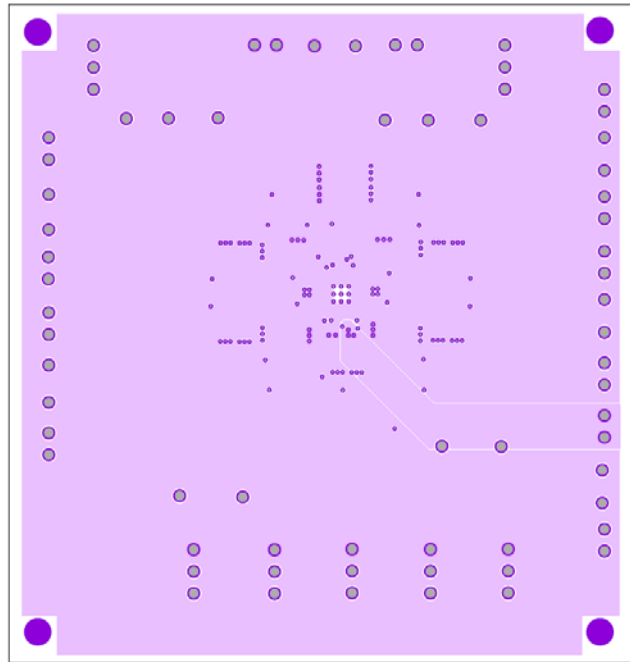

Figure 5. Layer 3, Power Plane

16697-005

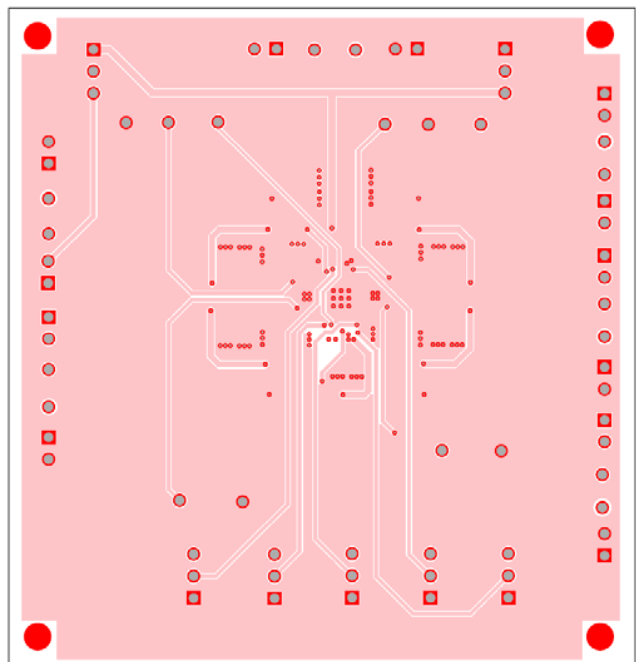

Figure 7. Layer 4, Bottom Side

16697-007

## ORDERING INFORMATION

## BILL OF MATERIALS

Table 1. Bill of Materials for the ADP5138W-1-EVALZ

Qty	Reference Designator	Description	Part Number/Vendor	Vendor
1	C1	Capacitor, 0.1 $\mu$ F, 16 V, 0603	GRM188R71C104KA01D	Murata
1	C2	Optional capacitor, 1206	Optional	Murata
1	C3	Capacitor, 22 $\mu$ F, 6.3 V, 1206	GRM31CR70J226KE19L	Murata
8	C4, C5, C7, C8, C10, C11, C13, C15	Capacitors, 10 $\mu$ F, 6.3 V, 0805	GCM21BR70J106KE22L	Murata
4	C6, C9, C12, C14	Optional capacitors, 0805	Optional	Murata
2	C16, C17	Capacitors, 1 $\mu$ F, 16 V, 0603	GCM188R71C105KA64D	Murata
5	C18, C19, C20, C21, C22	Optional capacitors, 0603	Optional	Murata
4	L1, L2, L3, L4 <sup>1</sup>	Chip inductors, 1.0 $\mu$ H, IRAT = 1.4 A, DCR = 85 m $\Omega$	LQM2MPZ1R0NG0L	Murata
1	R1	Resistor, 100 k $\Omega$ , 1%, 0603	CRCW0603100KFKEA	Vishay Dale
1	R2	Resistor, 10 $\Omega$ , 1%, 0603	CRCW060310R0FKEA	Vishay Dale
2	R3, R15	Resistors, 0 $\Omega$ , 0603	CRCW06030000Z0EA	Vishay Dale
12	R4, R6, R7, R9, R10, R13, R14, R16, R17, R18, R20, R22	Optional resistors, 0603	Optional	Vishay Dale
1	R5	Resistor, 1.62 k $\Omega$ , 1%, 0603	CRCW06031K62FKEA	Vishay Dale
1	R8	Resistor, 6.49 k $\Omega$ , 1%, 0603	CRCW06036K49FKEA	Vishay Dale
1	R11	Resistor, 5.36 k $\Omega$ , 1%, 0603	CRCW06035K36FKEA	Vishay Dale
1	R12	Resistor, 9.53 k $\Omega$ , 1%, 0603	CRCW06039K53FKEA	Vishay Dale
1	R19	Resistor, 18.7 k $\Omega$ , 1%, 0603	CRCW060318K7FKEA	Vishay Dale
1	R21	Resistor, 15 k $\Omega$ , 1%, 0603	CRCW060315K0FKEA	Vishay Dale
1	U1	Quad 1 A, 5.5 V, synchronous step-down regulators with one RF LDO regulator	<a href="#">ADP5138WACPZ-1-R7</a>	Analog Devices
22	J1, J4, J5, J9, J10, J14, J19, J26, J28 to J41	Test points, 2.54 mm pitch safety integrity level (SIL) vertical PC tail pin header, 6.1 mm mating pin height, tin, SIP1	M20-9990245	Harwin
12	J2, J6, J7, J8, J11, J12, J16, J17, J20, J21, J23, J24	Connectors, 2.54 mm pitch SIL vertical PC tail pin header, 6.1 mm mating pin height, tin, two way, SIP2	M20-9990245	Harwin
7	J3, J13, J15, J18, J22, J25, J27	Jumpers, 0.1-inch header, three way, SIP3	M20-9990346	Harwin

<sup>1</sup> IRAT is the saturation current of the inductor. DCR is the dc resistance of the inductor.



## NOTES

**ESD Caution**

**ESD (electrostatic discharge) sensitive device.** Charged devices and circuit boards can discharge without detection. Although this product features patented or proprietary protection circuitry, damage may occur on devices subjected to high energy ESD. Therefore, proper ESD precautions should be taken to avoid performance degradation or loss of functionality.

**Legal Terms and Conditions**

By using the evaluation board discussed herein (together with any tools, components documentation or support materials, the "Evaluation Board"), you are agreeing to be bound by the terms and conditions set forth below ("Agreement") unless you have purchased the Evaluation Board, in which case the Analog Devices Standard Terms and Conditions of Sale shall govern. Do not use the Evaluation Board until you have read and agreed to the Agreement. Your use of the Evaluation Board shall signify your acceptance of the Agreement. This Agreement is made by and between you ("Customer") and Analog Devices, Inc. ("ADI"), with its principal place of business at One Technology Way, Norwood, MA 02062, USA. Subject to the terms and conditions of the Agreement, ADI hereby grants to Customer a free, limited, personal, temporary, non-exclusive, non-sublicensable, non-transferable license to use the Evaluation Board FOR EVALUATION PURPOSES ONLY. Customer understands and agrees that the Evaluation Board is provided for the sole and exclusive purpose referenced above, and agrees not to use the Evaluation Board for any other purpose. Furthermore, the license granted is expressly made subject to the following additional limitations: Customer shall not (i) rent, lease, display, sell, transfer, assign, sublicense, or distribute the Evaluation Board; and (ii) permit any Third Party to access the Evaluation Board. As used herein, the term "Third Party" includes any entity other than ADI, Customer, their employees, affiliates and in-house consultants. The Evaluation Board is NOT sold to Customer; all rights not expressly granted herein, including ownership of the Evaluation Board, are reserved by ADI. CONFIDENTIALITY. This Agreement and the Evaluation Board shall all be considered the confidential and proprietary information of ADI. Customer may not disclose or transfer any portion of the Evaluation Board to any other party for any reason. Upon discontinuation of use of the Evaluation Board or termination of this Agreement, Customer agrees to promptly return the Evaluation Board to ADI. ADDITIONAL RESTRICTIONS. Customer may not disassemble, decompile or reverse engineer chips on the Evaluation Board. Customer shall inform ADI of any occurred damages or any modifications or alterations it makes to the Evaluation Board, including but not limited to soldering or any other activity that affects the material content of the Evaluation Board. Modifications to the Evaluation Board must comply with applicable law, including but not limited to the RoHS Directive. TERMINATION. ADI may terminate this Agreement at any time upon giving written notice to Customer. Customer agrees to return to ADI the Evaluation Board at that time. LIMITATION OF LIABILITY. THE EVALUATION BOARD PROVIDED HEREUNDER IS PROVIDED "AS IS" AND ADI MAKES NO WARRANTIES OR REPRESENTATIONS OF ANY KIND WITH RESPECT TO IT. ADI SPECIFICALLY DISCLAIMS ANY REPRESENTATIONS, ENDORSEMENTS, GUARANTEES, OR WARRANTIES, EXPRESS OR IMPLIED, RELATED TO THE EVALUATION BOARD INCLUDING, BUT NOT LIMITED TO, THE IMPLIED WARRANTY OF MERCHANTABILITY, TITLE, FITNESS FOR A PARTICULAR PURPOSE OR NON-INFRINGEMENT OF INTELLECTUAL PROPERTY RIGHTS. IN NO EVENT WILL ADI AND ITS LICENSORS BE LIABLE FOR ANY INCIDENTAL, SPECIAL, INDIRECT, OR CONSEQUENTIAL DAMAGES RESULTING FROM CUSTOMER'S POSSESSION OR USE OF THE EVALUATION BOARD, INCLUDING BUT NOT LIMITED TO LOST PROFITS, DELAY COSTS, LABOR COSTS OR LOSS OF GOODWILL. ADI'S TOTAL LIABILITY FROM ANY AND ALL CAUSES SHALL BE LIMITED TO THE AMOUNT OF ONE HUNDRED US DOLLARS (\$100,000). EXPORT. Customer agrees that it will not directly or indirectly export the Evaluation Board to another country, and that it will comply with all applicable United States federal laws and regulations relating to exports. GOVERNING LAW. This Agreement shall be governed by and construed in accordance with the substantive laws of the Commonwealth of Massachusetts (excluding conflict of law rules). Any legal action regarding this Agreement will be heard in the state or federal courts having jurisdiction in Suffolk County, Massachusetts, and Customer hereby submits to the personal jurisdiction and venue of such courts. The United Nations Convention on Contracts for the International Sale of Goods shall not apply to this Agreement and is expressly disclaimed.