



DPD/PA TEST REPORT

RF Transceiver	AD9375
Power Amplifier	SKY66397-12
PA Type	High Efficiency Semi-Linear PA
Transistor Type	SWKS HBT
Operating Frequency Range (MHz)	2496 – 2690
Gain (dB)	35
Power Added Efficiency	31% @ +28 dBm
OP3dB (dBm)	+36
Supply Voltage	+5 V
Bandwidths Tested	40 MHz



SUMMARY

Frequency	Output Power (dBm rms)	Signal Bandwidth	Test Signal	ACLR +1 (dBc)	ACLR-1 (dBc)	ACLR+2 (dBc)	ACLR-2 (dBc)	Power Added Efficiency (%)
2516MHz (Bottom)	+28	40 MHz	ETM3.1 20 MHz LTE 2 Carrier	-49.5	-49.5	-50.3	-50.2	31.5
2630 MHz (Middle)	+28	40 MHz	ETM3.1 20 MHz LTE 2 Carrier	-52.6	-52.6	-53.6	-52.8	31.1
2670 MHz (Top)	+28	40 MHz	ETM3.1 20 MHz LTE 2 Carrier	-50.6	-51.0	-50.1	-50.5	30.9

BLOCK DIAGRAM

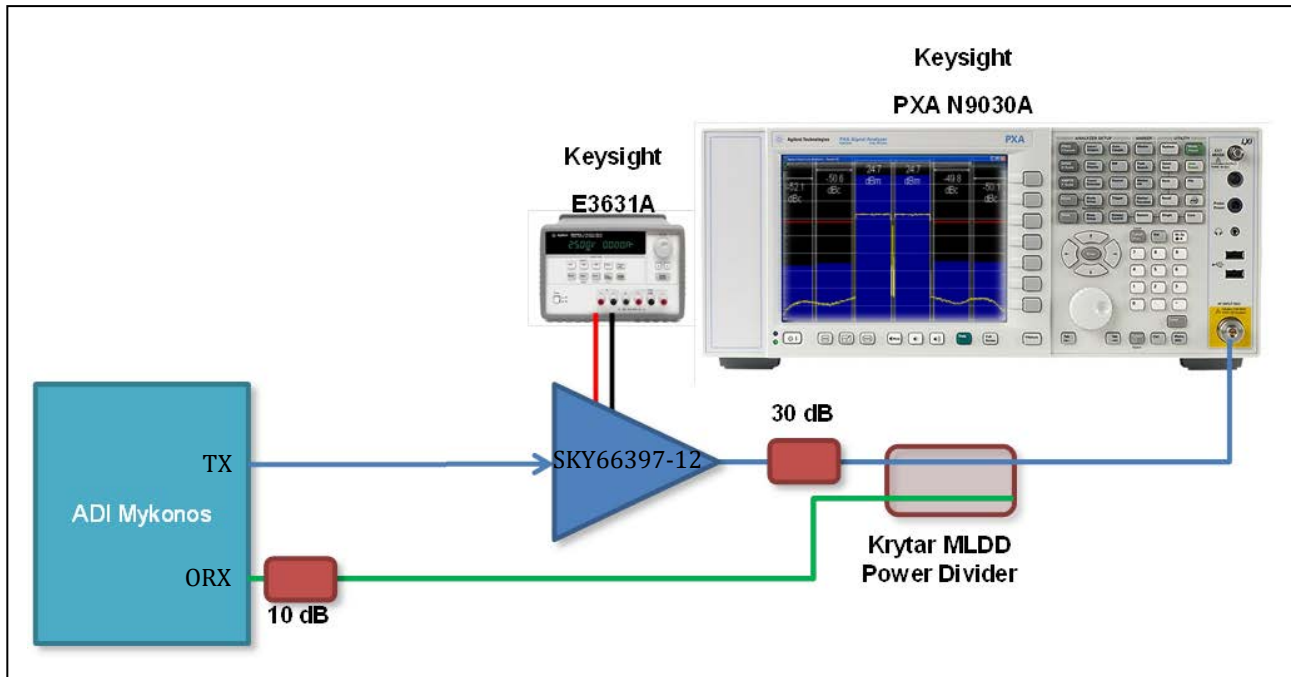

ACLR RESULTS BOTTOM/MIDDLE/TOP FREQUENCIES

2516MHZ, 40 MHZ BANDWIDTH ACLR RESULTS

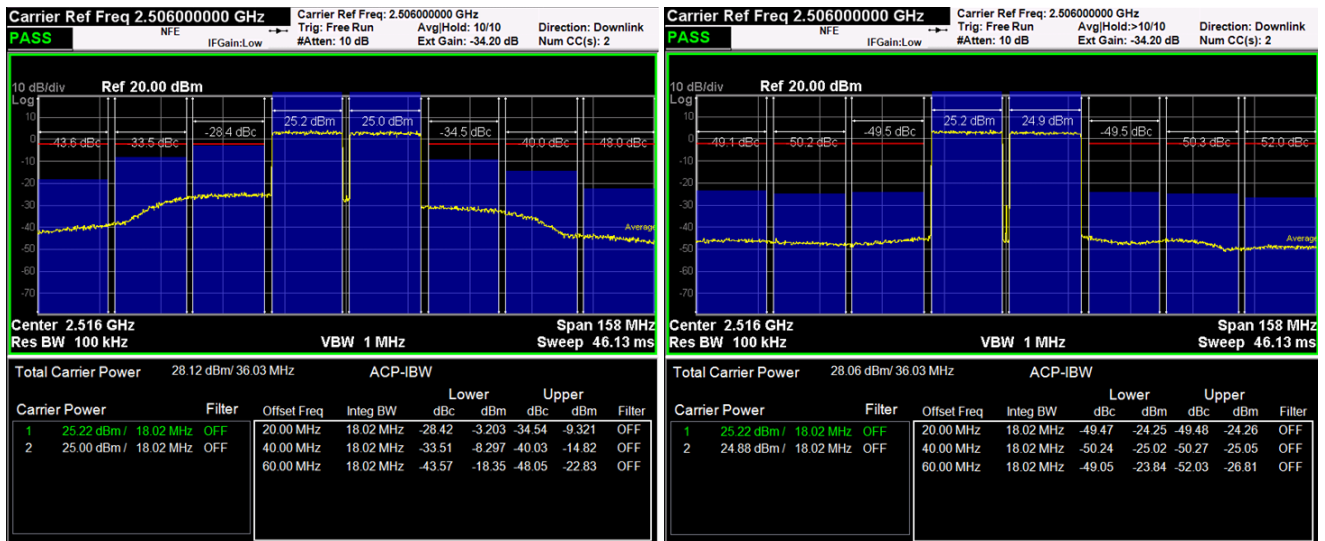

Figure 1. SKY66397-12 @ 2516MHz, 20 MHz ETM3.1 signal 2Carrier before/after DPD

Before/After DPD	Output Power (rms)	ACLR+1 (dBc)	ACLR-1 (dBc)	ACLR+2 (dBc)	ACLR-2 (dBc)	ACLR+3 (dBc)	ACLR-3 (dBc)	Drain Current (mA)	PAE (%)
Before DPD	+28.1	-34.5	-28.4	-40.0	-33.5	-48.1	-43.6	413	31.3
After DPD	+28.1	-49.5	-49.5	-50.3	-50.2	-52.0	-49.1	410	31.5

Table 1. Summary of Results: Frequency: 2516MHz, 20MHz ETM3.1 Signal 2Carrier

PA settings: Vcc1 = Vcc2 = Vcc3 = VBias = 5.0 V, Ven = 2.0 V Signal Used : ETM3.1

AD9375 DPD configuration

GUI Version: 2.0.68
 DLL Version: 1.5.2.3566
 Cmd Server Version: 1.5.2.3566
 Fpga Version: 46000200
 Arm Version: 5.2.2
 Analog Devices Inc.
 Copyright (c) 2017

2630 MHZ, 40 MHZ BANDWIDTH ACLR RESULTS

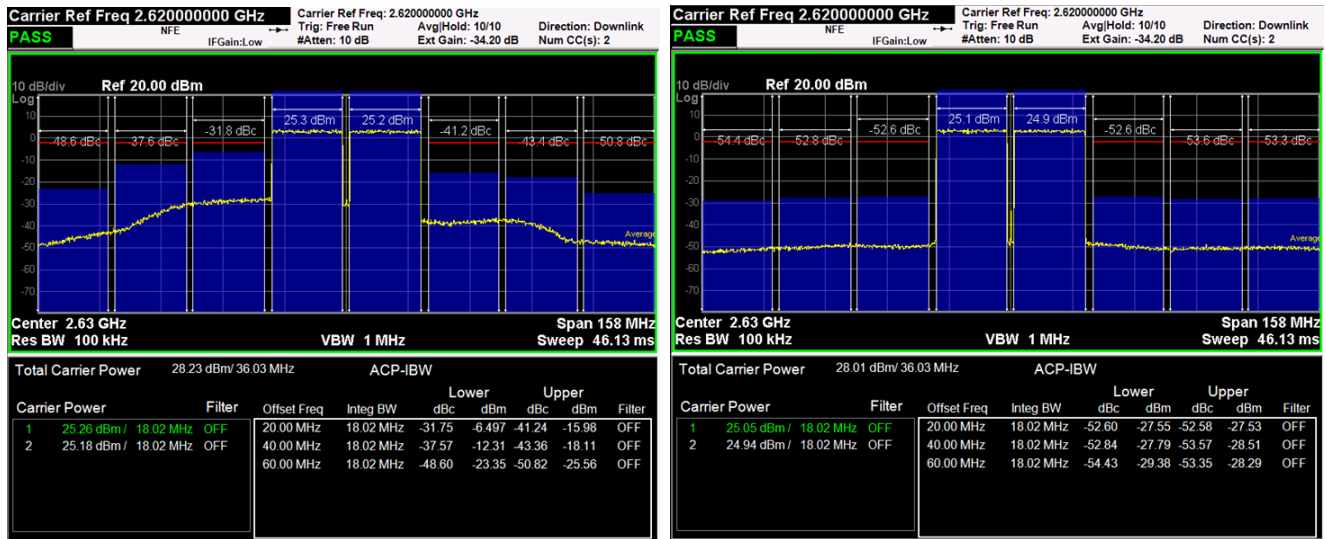

Figure 2. SKY66397-12 @ 2630 MHz, 20 MHz ETM3.1 signal 2Carrier before/after DPD

Before/After DPD	Output Power (rms)	ACLR+1 (dBc)	ACLR-1 (dBc)	ACLR+2 (dBc)	ACLR-2 (dBc)	ACLR+3 (dBc)	ACLR-3 (dBc)	Drain Current (mA)	PAE (%)
Before DPD	+28.2	-41.2	-31.8	-43.4	-37.6	-50.8	-48.6	422	31.3
After DPD	+28.0	-52.6	-52.6	-53.6	-52.8	-53.4	-54.4	406	31.1

Table 2. Summary of Results: Frequency: 2630 MHz, 20MHz ETM3.1 Signal 2Carrier

PA settings: Vcc1 = Vcc2 = Vcc3 = Vbias = 5.0 V, Ven = 2.0 V Signal Used: ETM3.1

AD9375 DPD configuration

2670 MHZ, 40 MHZ BANDWIDTH ACLR RESULTS



Figure 3. SKY66397-11 @ 2670 MHz, 20 MHz ETM3.1 signal 2Carrier before/after DPD

Before/After DPD	Output Power (rms)	ACLR+1 (dBc)	ACLR-1 (dBc)	ACLR+2 (dBc)	ACLR-2 (dBc)	ACLR+3 (dBc)	ACLR-3 (dBc)	Drain Current (mA)	PAE (%)
Before DPD	+28.2	-37.3	-31.2	-39.7	-37.1	-46.1	-48.0	430	30.7
After DPD	+28.0	-50.6	-51.0	-50.1	-50.5	-52.0	-52.9	408	30.9

Table 3. Summary of Results: Frequency: 2670 MHz, 20MHz ETM3.1 Signal 2Carrier

PA settings: Vcc1 = Vcc2 = Vcc3 = VBias = 5.0 V, Ven = 2.0 V Signal Used : ETM3.1

AD9375 DPD configuration

IP Address: 192.168.1.10 Tx Channel: 2
 Tx Interface rate: 153.6 MHz ORx Interface rate: 307.2 MHz

PA Settings: PA1 GPIO: 0 PA2 GPIO: 0 PA 2 On

DPD Status: Total Adaptations: 846 Current model error: 1.8% External sample delay: 146.313 samples
 DPD Initialized. (OK) - No Error

DPD Configuration: Target PAPR: 7.5 dB Digital Scale: -3 dBFS Digital Freq Offset: 0 MHz

PA Calibrations: Enable CLCC: [] VSWR Measure: [] DPD Adaptation: []

DPD Error Metrics: AM-AM Error: 99.87% CLCC: Disabled | Correct | Tx Attrs

WIDEBAND PLOTS, BOTTOM/MIDDLE/TOP FREQUENCIES

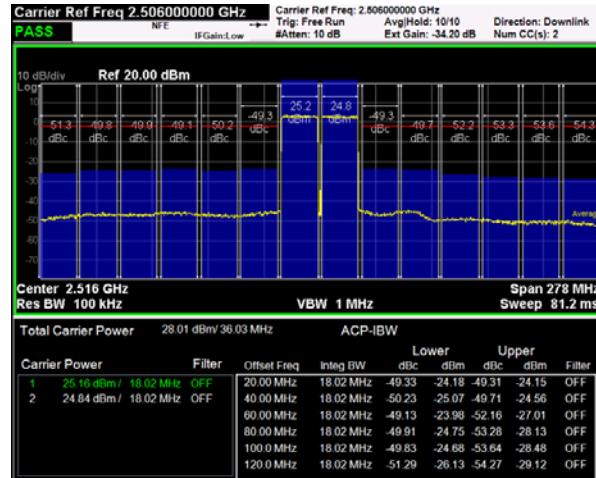

Figure 4. Wideband Spectrum Analyser Plot: Frequency 2516MHZ, 20 MHz ETM3.1 Signal 2Carrier

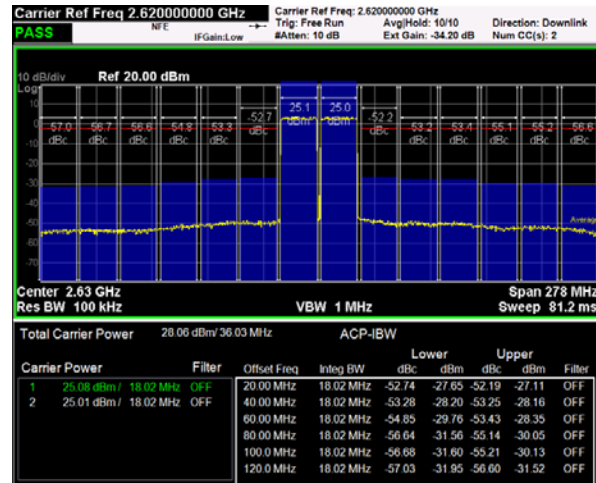

Figure 5. Wideband Spectrum Analyser Plot: Frequency 2630MHZ, 20 MHz ETM3.1 Signal 2Carrier

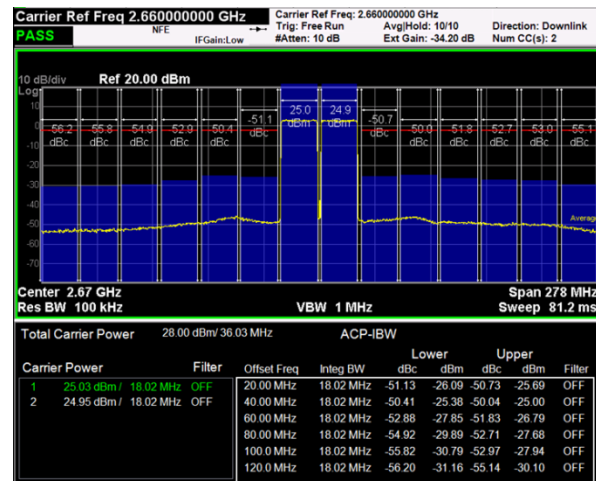

Figure 6. Wideband Spectrum Analyser Plot: Frequency 2670MHZ, 20 MHz ETM3.1 Signal 2Carrier

ACLR VS POUT

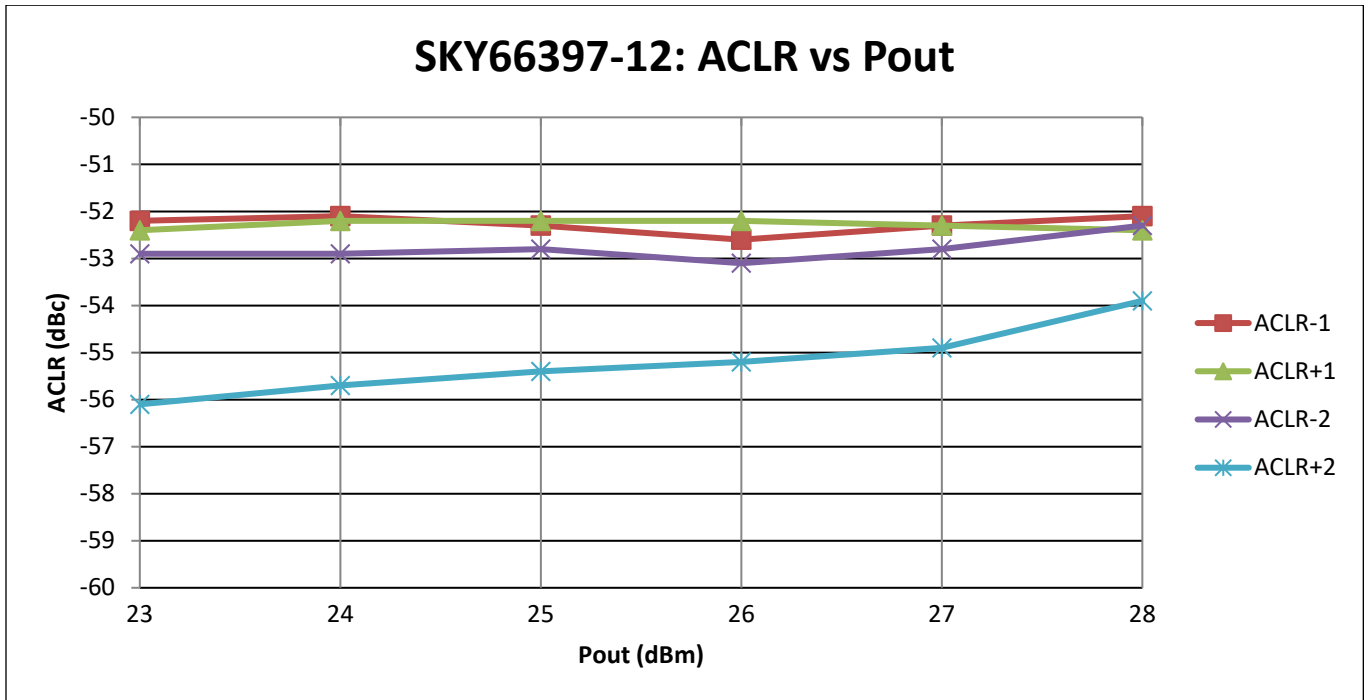

Figure 7. ACLR vs Output Power (2630 MHz)

INDEX

TEST BENCH

Keysight PXA Signal Analyzer N9030A with 89601B LTE Option

Keysight E3631A Power Supply 3-Output Power Supply