



DPD/PA TEST REPORT

RF Transceiver	AD9375
Power Amplifier	SKY66295-11
PA Type	High Efficiency Semi-Linear PA
Transistor Type	SWKS HBT
Operating Frequency Range (MHz)	850 – 900 MHz
Gain (dB)	33 (min)
Power Added Efficiency	35%
OP3dB (dBm)	+33
Supply Voltage	5V
Bandwidths Tested	10MHz



SUMMARY

Frequency	Output Power (dBm rms)	Signal Bandwidth	Test Signal	ACLR +1 (dBc)	ACLR-1 (dBc)	ACLR+2 (dBc)	ACLR-2 (dBc)	Power Added Efficiency (%)
860 MHz (Bottom)	27	10MHz	ETM3.1 10MHz LTE	-49.9	-49.3	-56	-55	35.7
880 MHz (Middle)	27	10MHz	ETM3.1 10MHz LTE	-49.22	-49.4	-54.5	-54	35
895 MHz (Top)	27	10MHz	ETM3.1 10MHz LTE	-50.2	-50	-56	-55.5	35.1

BLOCK DIAGRAM

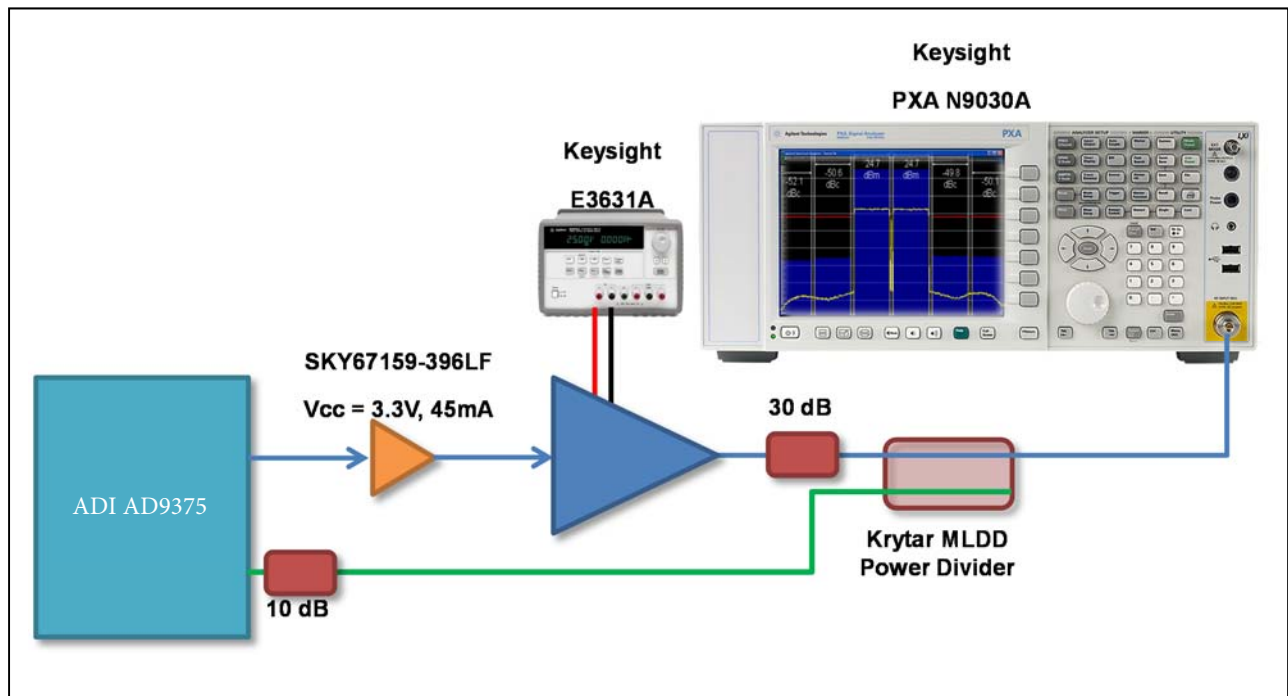

ACLR RESULTS BOTTOM/MIDDLE/TOP FREQUENCIES
860 MHz, 10MHz BANDWIDTH ACLR RESULTS

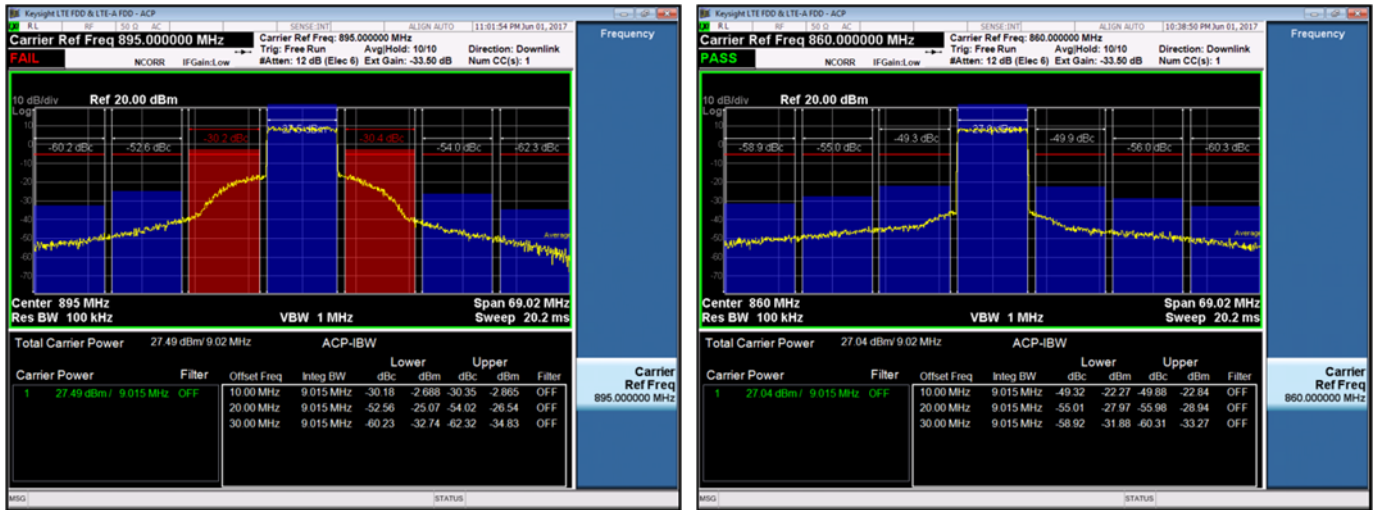

Figure: 1. Frequency 860 MHz, 10MHz ETM3.1Signal

Before/After DPD	Output Power (rms)	ACLR+1 (dBc)	ACLR-1 (dBc)	ACLR+2 (dBc)	ACLR-2 (dBc)	ACLR+3 (dBc)	ACLR-3 (dBc)	Drain Current (mA)	PAE (%)
Before DPD	+27.5	-30.35	-30.18	-54	-52.6	-62.3	-60.23	300	37.4
After DPD	+27	-49.9	-49.32	-56	-55	-60.3	-58.9	280	35.7

Table 1: Summary of Results: Frequency: 860 MHz, 10MHz ETM3.1 Signal

PA settings: Vcc1 = Vcc2 = Vcc3 = VBias = 5.0V, Ven = 2.0V Signal Used : ETM3.1

AD9375 DPD configuration

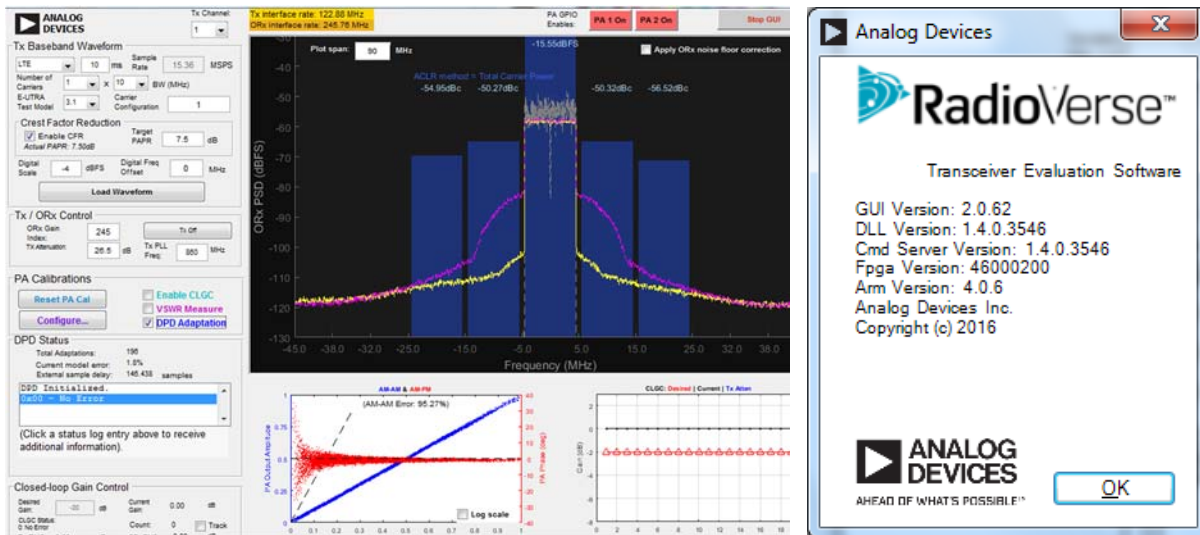

880 MHz, 10MHz BANDWIDTH ACLR RESULTS

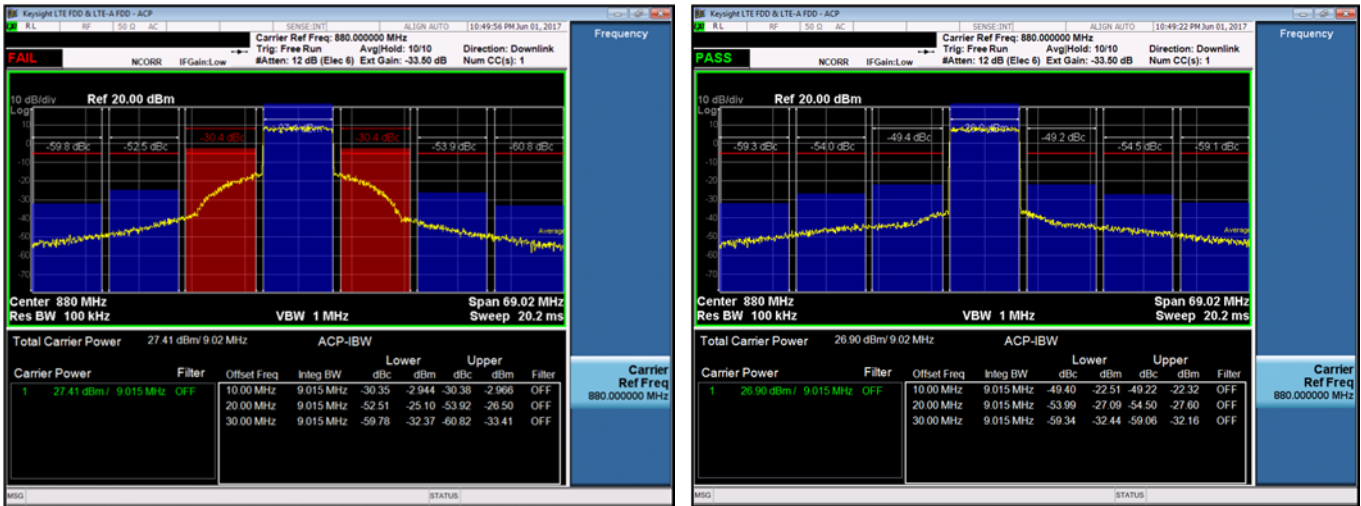

Figure 2: Frequency 880 MHz, 10MHz ETM3.1 Signal

Before/After DPD	Output Power (rms)	ACLR+1 (dBc)	ACLR-1 (dBc)	ACLR+2 (dBc)	ACLR-2 (dBc)	ACLR+3 (dBc)	ACLR-3 (dBc)	Drain Current (mA)	PAE (%)
Before DPD	+27.4	-30.4	-30.3	-53.9	-52.5	-60.82	-59.8	298	36.8
After DPD	+27	-49.22	-49.4	-54.5	-54	-59.1	-59.3	280	35.7

Table 2: Summary of Results: Frequency: 880 MHz, 10MHz ETM3.1 Signal

PA settings: Vcc1 = Vcc2 = Vcc3 = V Bias = 5.0V, Ven = 2.0V Signal Used : ETM3.1

AD9375 DPD configuration

895 MHZ, 10MHZ BANDWIDTH ACLR RESULT

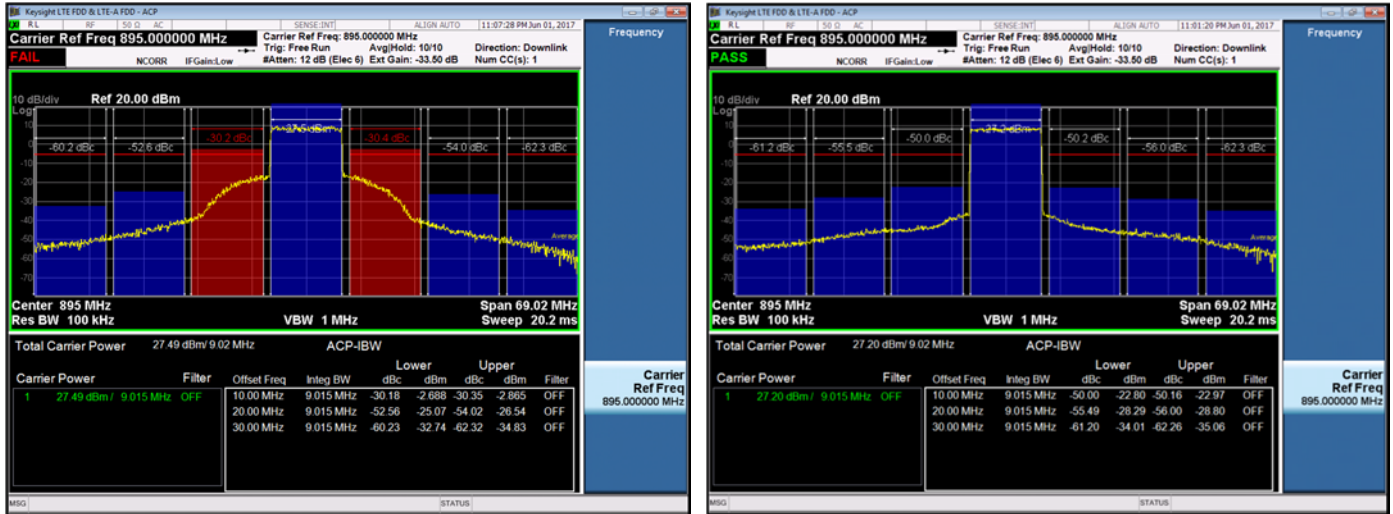

Figure 3: Frequency 895 MHz, 10MHz ETM3.1Signal

Before/After DPD	Output Power (rms)	ACLR+1 (dBc)	ACLR-1 (dBc)	ACLR+2 (dBc)	ACLR-2 (dBc)	ACLR+3 (dBc)	ACLR-3 (dBc)	Drain Current (mA)	PAE (%)
Before DPD	+27.5	-30.3	-30.2	-54	-52.6	-62.3	-60.3	290	38.7
After DPD	+27.2	-50.2	-50	-56	-55.5	-62.3	-61.2	288	36.4

Table 3: Summary of Results: Frequency: 895 MHz, 10MHz ETM3.1 Signal

PA settings: Vcc1 = Vcc2 = Vcc3 = VBias = 5.0V, Ven = 2.0V Signal Used : ETM3.1

AD9375 DPD configuration

The screenshot shows the AD9375 DPD configuration software. On the left, there are several control panels: 'Tx Channel' with waveform settings, 'Crest Factor Reduction' with 'Enable CFR' checked, and 'PA Calibrations' with 'Reset PA Cal' and 'Configure' buttons. The main display area shows a frequency spectrum plot with a carrier at 895 MHz and various ACLR values. Below the spectrum plot, there are two smaller graphs: one showing PA input amplitude vs. PA output amplitude, and another showing gain vs. time delay.

The screenshot shows the RadioVerse Transceiver Evaluation Software GUI. It displays the following version information: GUI Version: 2.0.62, DLL Version: 1.4.0.3546, Cmd Server Version: 1.4.0.3546, Fpga Version: 46000200, Arm Version: 4.0.6. The Analog Devices logo and 'AHEAD OF WHAT'S POSSIBLE' slogan are also visible.

WIDEBAND PLOTS, BOTTOM/MIDDLE/TOP FREQUENCIES



Figure 4: Wideband Spectrum Analyser Plot: Frequency 860 MHz, 10MHz ETM3.1 Signal

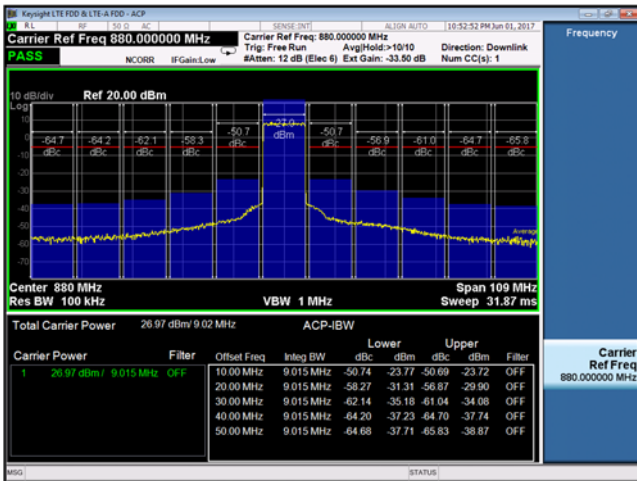

Figure 5: Wideband Spectrum Analyser Plot: Frequency 880.5MHz, 10MHz ETM3.1 Signal

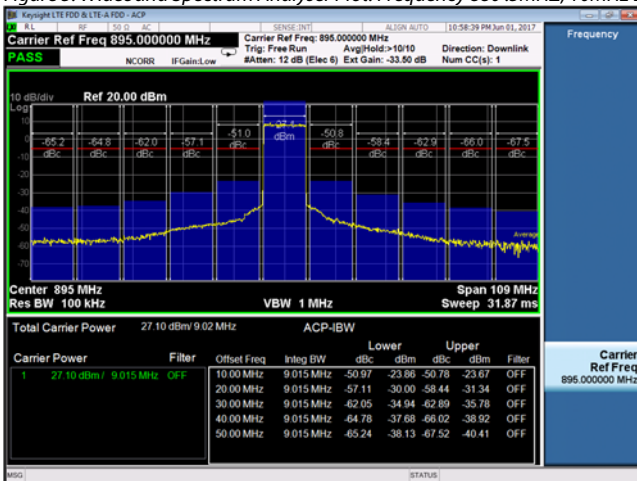

Figure 6: Wideband Spectrum Analyser Plot: Frequency 895 MHz, 10MHz ETM3.1 Signal

ACLR VS POUT

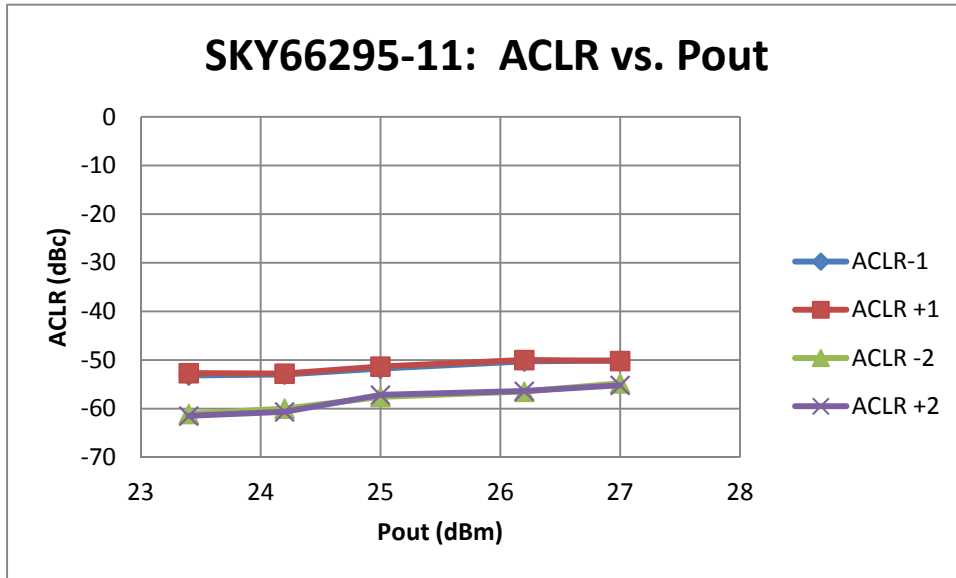

Figure 7: ACLR vs Output Power (880 MHz)

INDEX**DRIVER AMPLIFIER**

Part Number	SKY67159-396LF	SKY67153-396LF
Frequency Range (GHz) :	0.2-3.8	0.7-3.8
Test Frequency (GHz) :	0.7 2.7 3.8	0.849 2.50 3.60
Gain Typ. (dB) :	17.5 @ 700 MHz 17.0 @ 2.7GHz 16.5 @ 3.8GHz	26 @ 849 MHz 19.0 @ 2.5GHz 16.5 @ 3.8GHz
OIP3 (dBm) :	31 29 27@ 3.8GHz	34.5 @ 849 MHz 36.0@ 2.5GHz 36.0@ 3.8GHz
OP1 dB (dBm) :	18 16 14.5@ 3.8GHz	21.5 @ 849 MHz 20.0@ 2.5GHz 18.0@ 3.8GHz
VDD (V) :	3.3 or 5	5
Supply Current Typ. (mA) :	45	80
Noise Figure Typ. (dB) :	0.95 1 1.3@ 3.8GHz	0.25 @ 849 MHz 0.50@ 2.5GHz 0.70@ 3.8GHz
Package (mm) :	8-pin DFN, 2 x 2 x 0.75	8-pin DFN, 2 x 2 x 0.75

TEST BENCH

Keysight PXA Signal Analyzer N9030A with 89601B LTE Option

Keysight E3631A Power Supply 3-Output Power Supply