



DPD/PA TEST REPORT

RF Transceiver	AD9375
Power Amplifier	SKY66294-11
PA Type	High Efficiency Semi-Linear PA
Transistor Type	SWKS HBT
Operating Frequency Range (MHz)	2100–2200
Gain (dB)	36 (min)
Power Added Efficiency	33%
OP3dB (dBm)	+36
Supply Voltage	5V
Bandwidths Tested	20MHz



SUMMARY

Frequency	Output Power (dBm rms)	Signal Bandwidth	Test Signal	ACLR +1 (dBc)	ACLR-1 (dBc)	ACLR+2 (dBc)	ACLR-2 (dBc)	Power Added Efficiency (%)
2110MHz (Bottom)	+28	20MHz	ETM3.1 20MHz LTE	-53.6	-52.27	-57.98	-56.49	33.9
2155MHz (Middle)	+28	20MHz	ETM3.1 20MHz LTE	-52.7	-52	-59	-55.58	32.7
2200MHz (Top)	+28	20MHz	ETM3.1 20MHz LTE	-49.48	-47.7	-55	-53.5	34

BLOCK DIAGRAM

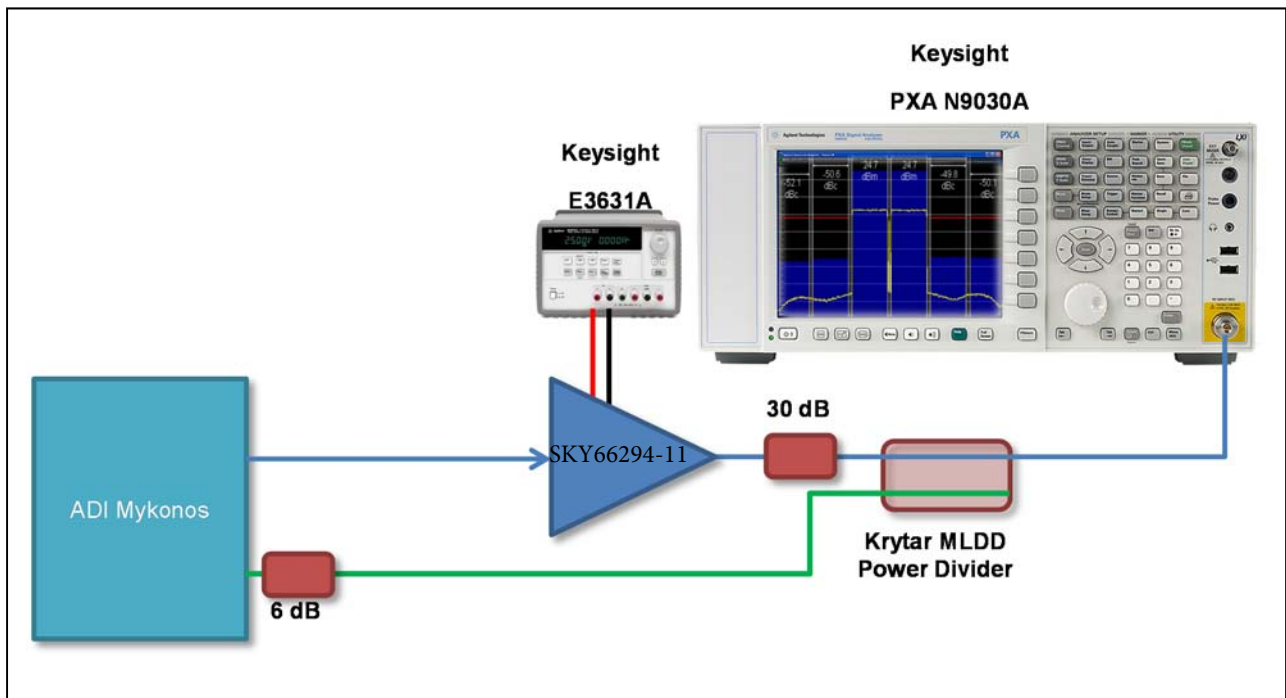

ACLR RESULTS BOTTOM/MIDDLE/TOP FREQUENCIES
2110MHZ, 20MHZ BANDWIDTH ACLR RESULTS



Figure: 1. Frequency 2110MHz, 20MHz ETM3.1 Signal

Before/After DPD	Output Power (rms)	ACLR+1 (dBc)	ACLR-1 (dBc)	ACLR+2 (dBc)	ACLR-2 (dBc)	ACLR+3 (dBc)	ACLR-3 (dBc)	Drain Current (mA)	PAE (%)
Before DPD	+28	-33.8	-33.3	-49.97	-49.54	-58.86	-58.38	372	33.9
After DPD	+28	-53.6	-52.27	-57.96	-56.49	-60	-58.5	362	34.8

Table 1: Summary of Results: Frequency: 2110MHz, 20MHz ETM3.1 Signal

PA settings: Vcc1 = Vcc2 = Vcc3 = VBias = 5.0V, Ven = 2.0V Signal Used: ETM3.1

AD9375 DPD configuration

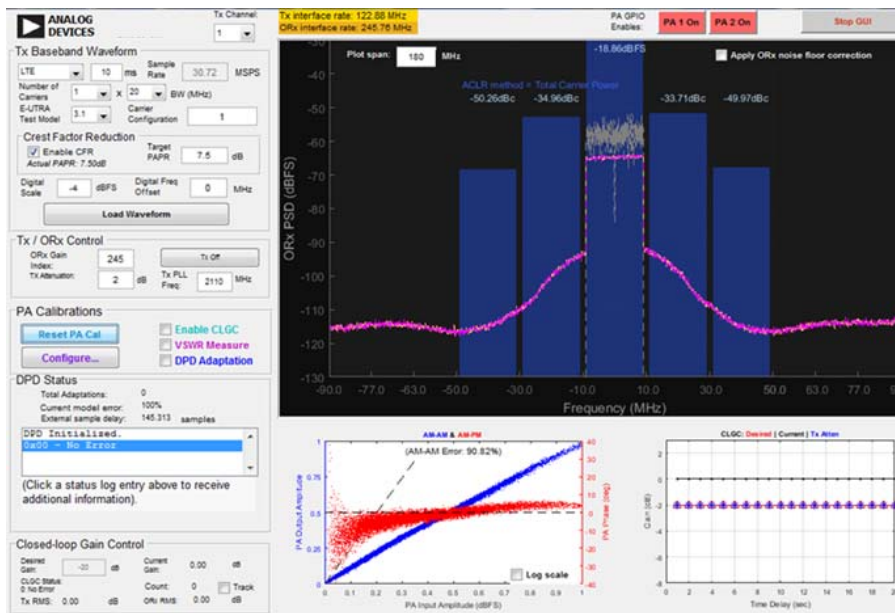

Analog Devices

RadioVerse™

Transceiver Evaluation Software

GUI Version: 2.0.62
 DLL Version: 1.4.0.3546
 Cmd Server Version: 1.4.0.3546
 Fpga Version: 46000200
 Arm Version: 4.0.6
 Analog Devices Inc.
 Copyright (c) 2016

ANALOG DEVICES
 AHEAD OF WHAT'S POSSIBLE!™

OK

2155MHZ, 20MHZ BANDWIDTH ACLR RESULTS



Figure 2: Frequency 2155MHz, 20MHz ETM3.1 Signal

Before/After DPD	Output Power (rms)	ACLR+1 (dBc)	ACLR-1 (dBc)	ACLR+2 (dBc)	ACLR-2 (dBc)	ACLR+3 (dBc)	ACLR-3 (dBc)	Drain Current (mA)	PAE (%)
Before DPD	+28	-33.83	-32.5	-48.15	-46	-58.6	-58.6	400	31.55
After DPD	+28	-52.79	-51.89	-59.12	-56	-62	-59	395	31.95

Table 2: Summary of Results: Frequency: 2155MHz, 20MHz ETM3.1 Signal

PA settings: Vcc1 = Vcc2 = Vcc3 = Vbias = 5.0V, Ven = 2.0V Signal Used: ETM3.1

AD9375 DPD configuration

2200MHZ, 20MHZ BANDWIDTH ACLR RESULT



Figure: 3. Frequency 2200 MHz, 20MHz ETM3.1 Signal

Before/After DPD	Output Power (rms)	ACLR+1 (dBc)	ACLR-1 (dBc)	ACLR+2 (dBc)	ACLR-2 (dBc)	ACLR+3 (dBc)	ACLR-3 (dBc)	Drain Current (mA)	PAE (%)
------------------	--------------------	--------------	--------------	--------------	--------------	--------------	--------------	--------------------	---------

Before DPD	+28.0	-31.84	-29	-45	-43.2	-56.74	-57.73	380	33.2
After DPD	+28	-49.5	-47.7	-55	-53.52	-57.6	-57.08	370	34.1

Table 3: Summary of Results: Frequency: 2200MHz, 20MHz ETM3.1 Signal

PA settings: Vcc1 = Vcc2 = Vcc3 = Vbias = 5.0V, Ven = 2.0V Signal Used: ETM3.1

AD9375 DPD configuration

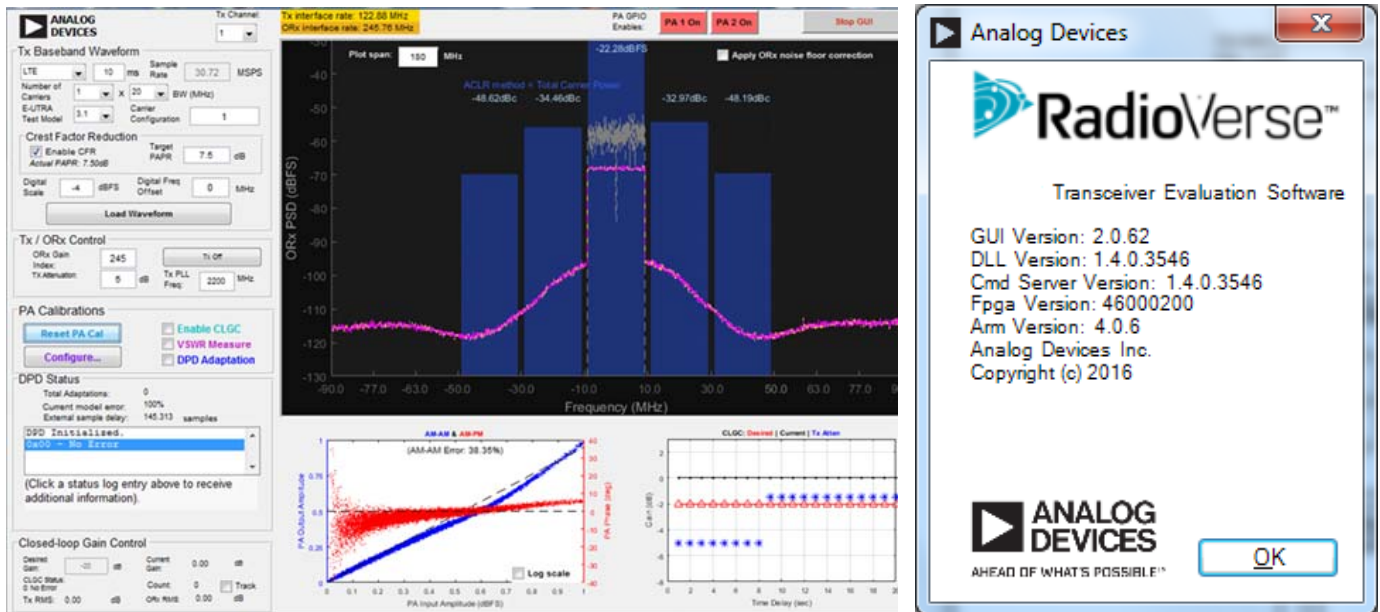

WIDEBAND PLOTS, BOTTOM/MIDDLE/TOP FREQUENCIES

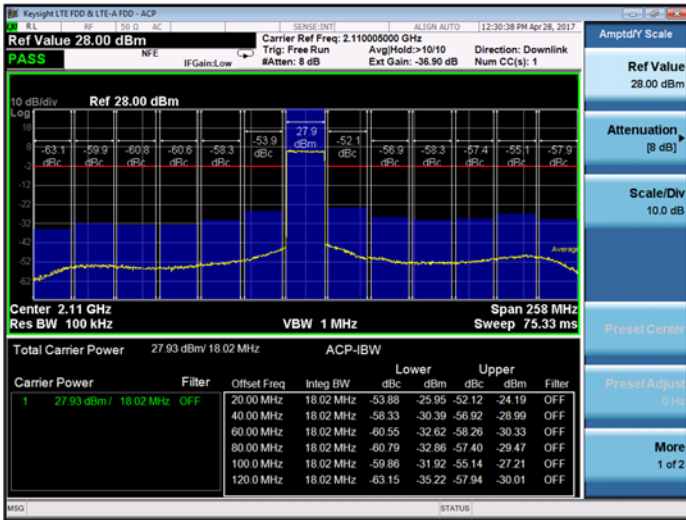

Figure 3: Wideband Spectrum Analyser Plot: Frequency 2110MHZ, 20MHz ETM3.1 Signal

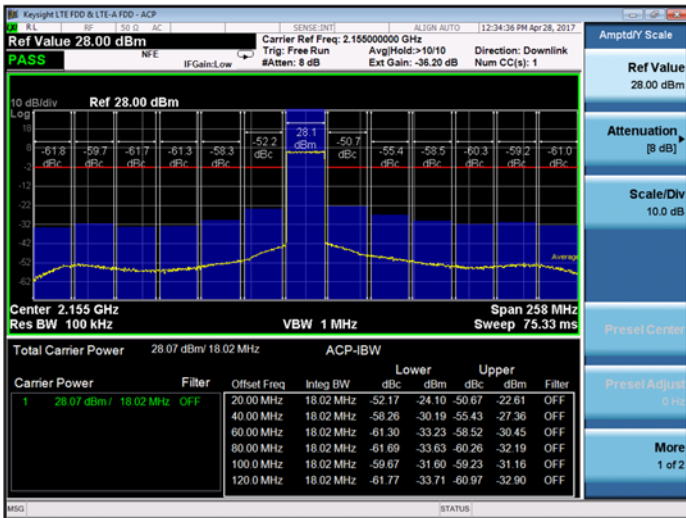

Figure 4: Wideband Spectrum Analyser Plot: Frequency 2155MHZ, 20MHz ETM3.1 Signal



Figure 5: Wideband Spectrum Analyser Plot: Frequency 2200MHZ, 20MHz ETM3.1 Signal

ACLR VS POUT

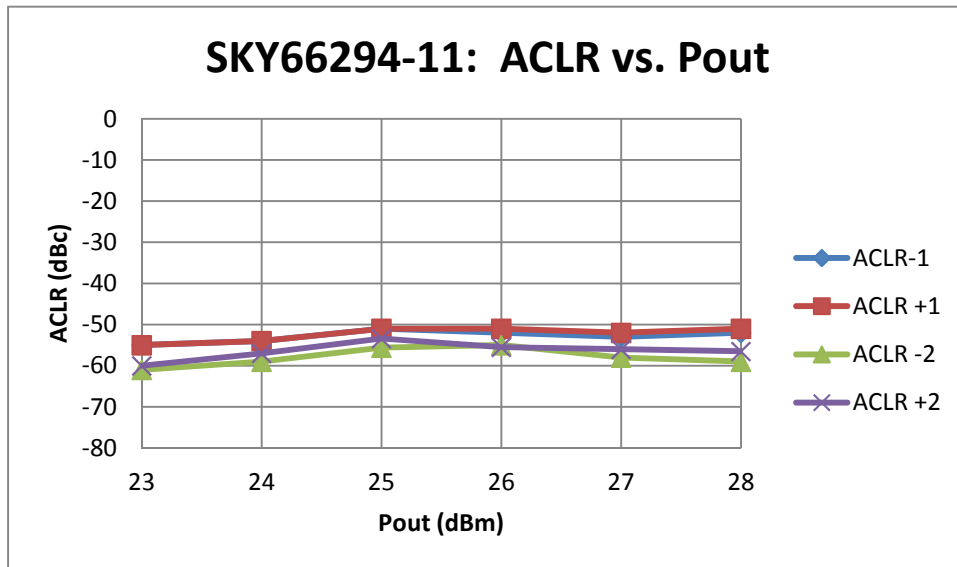

Figure 6: ACLR vs Output Power (Middle Frequency)

INDEX**DRIVER AMPLIFIER**

Part Number	SKY67159-396LF	SKY67153-396LF
Description	Lower current driver option Recommended if linearity target is easily achieved	Higher linearity driver for applications requiring better ACLR
Frequency Range (GHz) :	0.2-3.8	0.7-3.8
Test Frequency (GHz) :	0.7 2.7 3.8	0.849 2.50 3.60
Gain Typ. (dB) :	17.5 @ 700 MHz 17.0 @ 2.7GHz 16.5 @ 3.8GHz	26 @ 849 MHz 19.0 @ 2.5GHz 16.5 @ 3.8GHz
OIP3 (dBm) :	31 29 27@ 3.8GHz	34.5 @ 849 MHz 36.0@ 2.5GHz 36.0@ 3.8GHz
OP1 dB (dBm) :	18 16 14.5@ 3.8GHz	21.5 @ 849 MHz 20.0@ 2.5GHz 18.0@ 3.8GHz
VDD (V) :	3.3 or 5	5
Supply Current Typ. (mA) :	45	80
Noise Figure Typ. (dB) :	0.95 1 1.3@ 3.8GHz	0.25 @ 849 MHz 0.50@ 2.5GHz 0.70@ 3.8GHz
Package (mm) :	8-pin DFN, 2 x 2 x 0.75	8-pin DFN, 2 x 2 x 0.75

TEST BENCH

Keysight PXA Signal Analyzer N9030A with 89601B LTE Option

Keysight E3631A Power Supply 3-Output Power Supply