

RELIABILITY REPORT  
FOR  
**MAX314xxE**  
PLASTIC ENCAPSULATED DEVICES

January 27, 2003

**MAXIM INTEGRATED PRODUCTS**

120 SAN GABRIEL DR.

SUNNYVALE, CA 94086

Written by



Jim Pedicord  
Quality Assurance  
Reliability Lab Manager

Reviewed by



Bryan J. Preeshl  
Quality Assurance  
Executive Director

## Conclusion

The MAX314 successfully meets the quality and reliability standards required of all Maxim products. In addition, Maxim's continuous reliability monitoring program ensures that all outgoing product will continue to meet Maxim's quality and reliability standards.

## Table of Contents

I. ....Device Description	V. ....Quality Assurance Information
II. ....Manufacturing Information	VI. ....Reliability Evaluation
III. ....Packaging Information	
IV. ....Die Information	.....Attachments

### I. Device Description

#### A. General

The MAX314 analog switch features low on-resistance ( $10\Omega$  max) and  $1.5\Omega$  on-resistance matching between channels. This switch conducts equally well in either direction. It offers low leakage over temperature ( $2.5nA$  at  $+85^\circ C$ ). Low power consumption and ESD tolerance greater than  $2000V$  per Method 3015.7 are guaranteed.

The MAX314 is a quad, single-pole/single-throw (SPST) analog switch. The MAX314 has two NC switches and two NO switches. This device operates from a single supply of  $+4.5V$  to  $+30V$  or from dual supplies of  $\pm 4.5V$  to  $\pm 20V$ .

#### B. Absolute Maximum Ratings

<u>Item</u>	<u>Rating</u>
Voltages Referenced to GND	
V+	-0.3V to +44V
V-	+0.3V to -44V
V+ to V-	-0.3V to +44V
VL	(GND - 0.3V) to (V+ + 0.3V)
All the Pins (Note 1)	(V- - 2V) to (V+ + 2V) or 30mA (whichever occurs first)
Continuous Current (COM_, NO_, NC_)	$\pm 100mA$
Peak Current (COM_, NO_, NC_)	$\pm 300mA$
Storage Temp.	$-65^\circ C$ to $+150^\circ C$
Lead Temp. (10 sec.)	$+300^\circ C$
Continuous Power Dissipation (TA = $+70^\circ C$ )	
16-Pin PDIP	8.42mW
16-Pin SO	696mW
16-Pin TSSOP	457mW
Derates above $+70^\circ C$	
16-Pin PDIP	$10.53mW/^\circ C$
16-Pin SO	$8.7mW/^\circ C$
16-Pin TSSOP	$6.7mW/^\circ$

**Note 1:** Signals on NC\_, NO\_, COM\_, or IN\_ exceeding V+ or V- will be clamped by internal diodes. Limit forward diode current to maximum current rating.

## II. Manufacturing Information

A. Description/Function:	10Ω, Quad, SPST, CMOS Analog Switch
B. Process:	S5HV - Medium voltage 5 micron silicon gate CMOS
C. Number of Device Transistors:	100
D. Fabrication Location:	Oregon, USA
E. Assembly Location:	Philippines, Malaysia or Thailand
F. Date of Initial Production:	September, 1995

## III. Packaging Information

A. Package Type:	16 Lead TSSOP	16-Lead PDIP	16-Lead SO
B. Lead Frame:	Copper	Copper	Copper
C. Lead Finish:	Solder Plate	Solder Plate	Solder Plate
D. Die Attach:	Silver-filled Epoxy	Silver-filled Epoxy	Silver-filled Epoxy
E. Bondwire:	Gold (1.0 mil dia.)	Gold (1.3 mil dia.)	Gold (1.3 mil dia.)
F. Mold Material:	Epoxy with silica filler	Epoxy with silica filler	Epoxy with silica filler
G. Assembly Diagram:	# 05-0301-0868	# 05-0301-0727	# 05-0301-0728
H. Flammability Rating:	Class UL94-V0	Class UL94-V0	Class UL94-V0
I. Classification of Moisture Sensitivity per JEDEC standard JESD22-A112:	Level 1	Level 1	Level 1

## IV. Die Information

A. Dimensions:	85 x 140 mils
B. Passivation:	Si <sub>3</sub> N <sub>4</sub> /SiO <sub>2</sub> (Silicon nitride/ Silicon dioxide)
C. Interconnect:	Aluminum/Si (Si = 1%)
D. Backside Metallization:	None
E. Minimum Metal Width:	5 microns (as drawn)
F. Minimum Metal Spacing:	5 microns (as drawn)
G. Bondpad Dimensions:	5 mil. Sq.
H. Isolation Dielectric:	SiO <sub>2</sub>
I. Die Separation Method:	Wafer Saw

## V. Quality Assurance Information

- A. Quality Assurance Contacts: Jim Pedicord (Manager, Reliability Operations)  
Bryan Preeshl (Executive Director of QA)  
Kenneth Huening (Vice President)
- B. Outgoing Inspection Level: 0.1% for all electrical parameters guaranteed by the Datasheet.  
0.1% For all Visual Defects.
- C. Observed Outgoing Defect Rate: < 50 ppm
- D. Sampling Plan: Mil-Std-105D

## VI. Reliability Evaluation

### A. Accelerated Life Test

The results of the 135°C biased (static) life test are shown in **Table 1**. Using these results, the Failure Rate ( $\lambda$ ) is calculated as follows:

$$\lambda = \frac{1}{\text{MTTF}} = \frac{1.83}{192 \times 4389 \times 374 \times 2} \quad (\text{Chi square value for MTTF upper limit})$$

 Temperature Acceleration factor assuming an activation energy of 0.8eV

$$\lambda = 2.90 \times 10^{-9} \quad \lambda = 2.90\text{F.I.T. (60\% confidence level @ 25°C)}$$

This low failure rate represents data collected from Maxim's reliability qualification and monitor programs. Maxim also performs weekly Burn-In on samples from production to assure reliability of its processes. The reliability required for lots which receive a burn-in qualification is 59 F.I.T. at a 60% confidence level, which equates to 3 failures in an 80 piece sample. Maxim performs failure analysis on rejects from lots exceeding this level. The attached Burn-In Schematic (Spec. # 06-5002) shows the static circuit used for this test. Maxim also performs 1000 hour life test monitors quarterly for each process. This data is published in the Product Reliability Report (**RR-1M**).

### B. Moisture Resistance Tests

Maxim evaluates pressure pot stress from every assembly process during qualification of each new design. Pressure Pot testing must pass a 20% LTPD for acceptance. Additionally, industry standard 85°C/85%RH or HAST tests are performed quarterly per device/package family.

### C. E.S.D. and Latch-Up Testing

The AG77-2 die type has been found to have all pins able to withstand a transient pulse of  $\pm 1500\text{V}$ , per Mil-Std-883 Method 3015 (reference attached ESD Test Circuit). Latch-Up testing has shown that this device withstands a current of  $\pm 100\text{mA}$ .

**Table 1**  
Reliability Evaluation Test Results

**MAX314xxE**

<b>TEST ITEM</b>	<b>TEST CONDITION</b>	<b>FAILURE IDENTIFICATION</b>	<b>PACKAGE</b>	<b>SAMPLE SIZE</b>	<b>NUMBER OF FAILURES</b>
<b>Static Life Test</b> (Note 1)					
	Ta = 135°C Biased Time = 192 hrs.	DC Parameters & functionality		374	0
<b>Moisture Testing</b> (Note 2)					
Pressure Pot	Ta = 121°C P = 15 psi. RH= 100% Time = 168hrs.	DC Parameters & functionality	NSO	77	0
			PDIP	77	0
			TSSOP	77	0
85/85	Ta = 85°C RH = 85% Biased Time = 1000hrs.	DC Parameters & functionality		77	0
<b>Mechanical Stress</b> (Note 2)					
Temperature Cycle	-65°C/150°C 1000 Cycles Method 1010	DC Parameters & functionality		77	0

Note 1: Life Test Data may represent plastic DIP qualification lots.

Note 2: Generic Package/Process data

Attachment #1

TABLE II. Pin combination to be tested. 1/ 2/

	Terminal A (Each pin individually connected to terminal A with the other floating)	Terminal B (The common combination of all like-named pins connected to terminal B)
1.	All pins except $V_{PS1}$ 3/	All $V_{PS1}$ pins
2.	All input and output pins	All other input-output pins

1/ Table II is restated in narrative form in 3.4 below.

2/ No connects are not to be tested.

3/ Repeat pin combination 1 for each named Power supply and for ground

(e.g., where  $V_{PS1}$  is  $V_{DD}$ ,  $V_{CC}$ ,  $V_{SS}$ ,  $V_{BB}$ , GND,  $+V_S$ ,  $-V_S$ ,  $V_{REF}$ , etc).

3.4 Pin combinations to be tested.

- a. Each pin individually connected to terminal A with respect to the device ground pin(s) connected to terminal B. All pins except the one being tested and the ground pin(s) shall be open.
- b. Each pin individually connected to terminal A with respect to each different set of a combination of all named power supply pins (e.g.,  $V_{SS1}$ , or  $V_{SS2}$  or  $V_{SS3}$  or  $V_{CC1}$ , or  $V_{CC2}$ ) connected to terminal B. All pins except the one being tested and the power supply pin or set of pins shall be open.
- c. Each input and each output individually connected to terminal A with respect to a combination of all the other input and output pins connected to terminal B. All pins except the input or output pin being tested and the combination of all the other input and output pins shall be open.

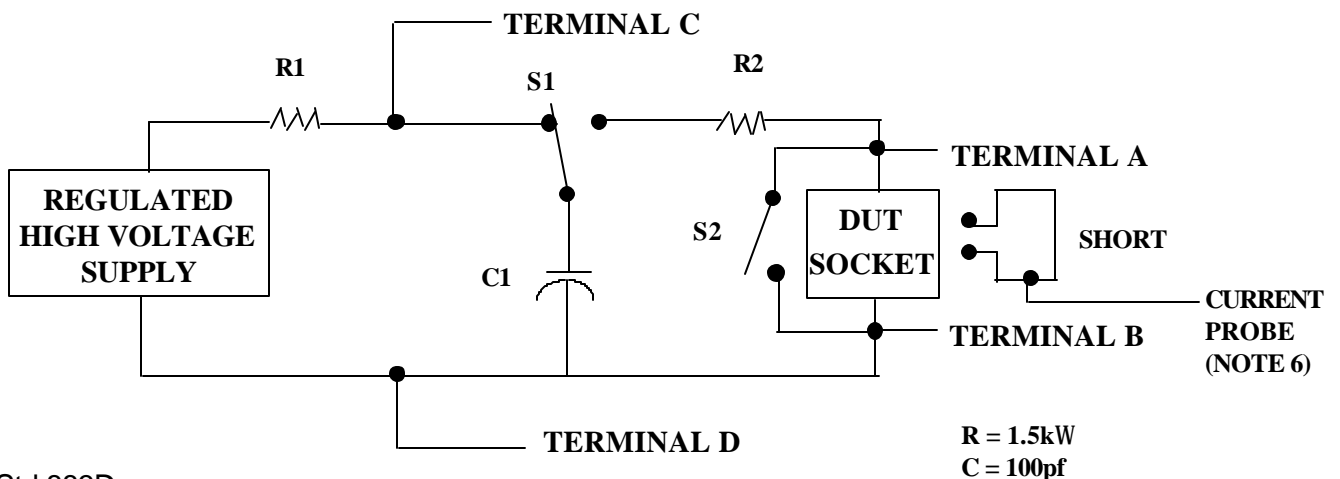

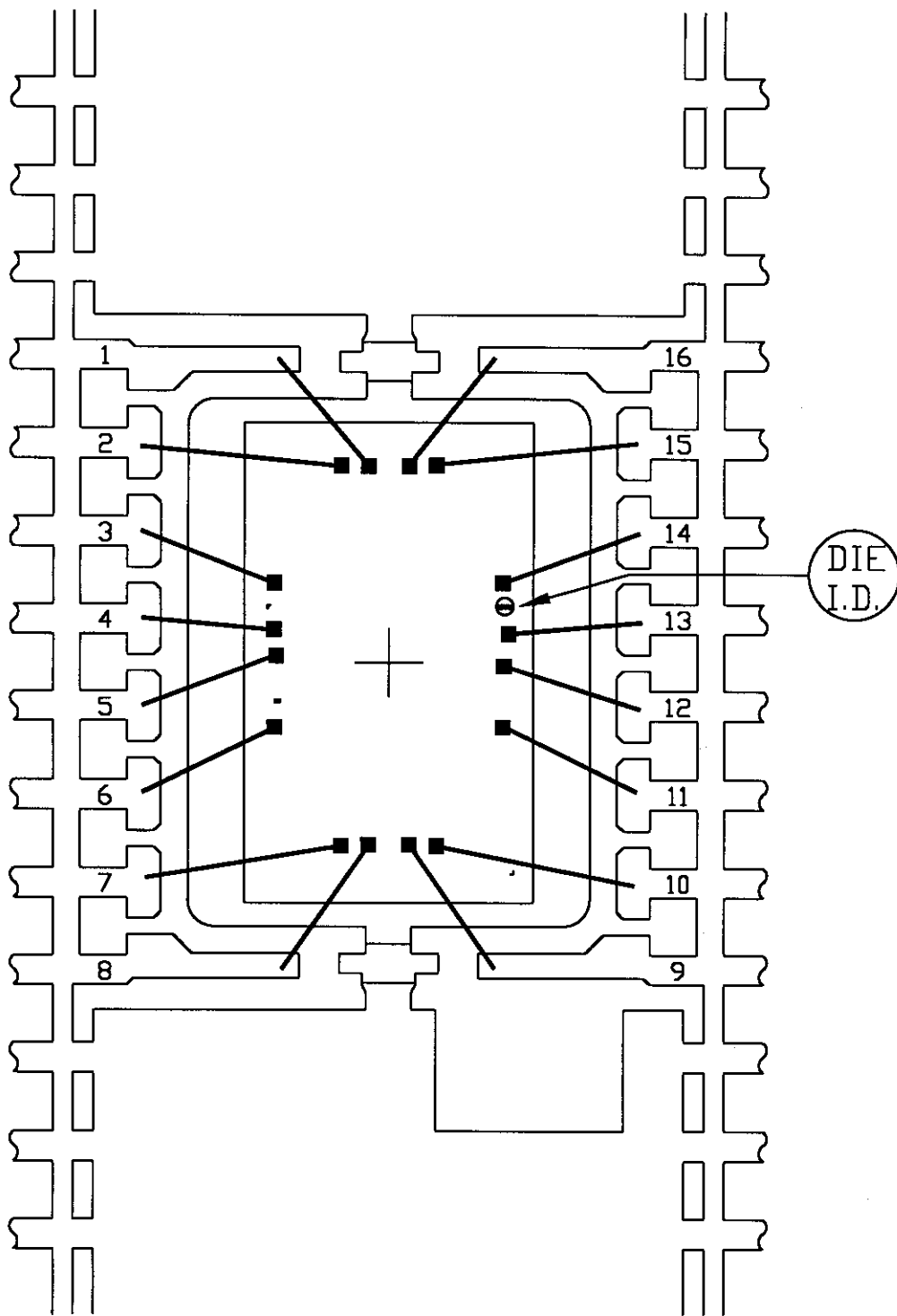

PKG.CODE: U16-1

CAV./PAD SIZE:  
118X154

APPROVALS

DATE

**MAXIM**

BUILDSHEET NUMBER:  
05-0301-0868

REV:  
A

PKG.  
DESIGN

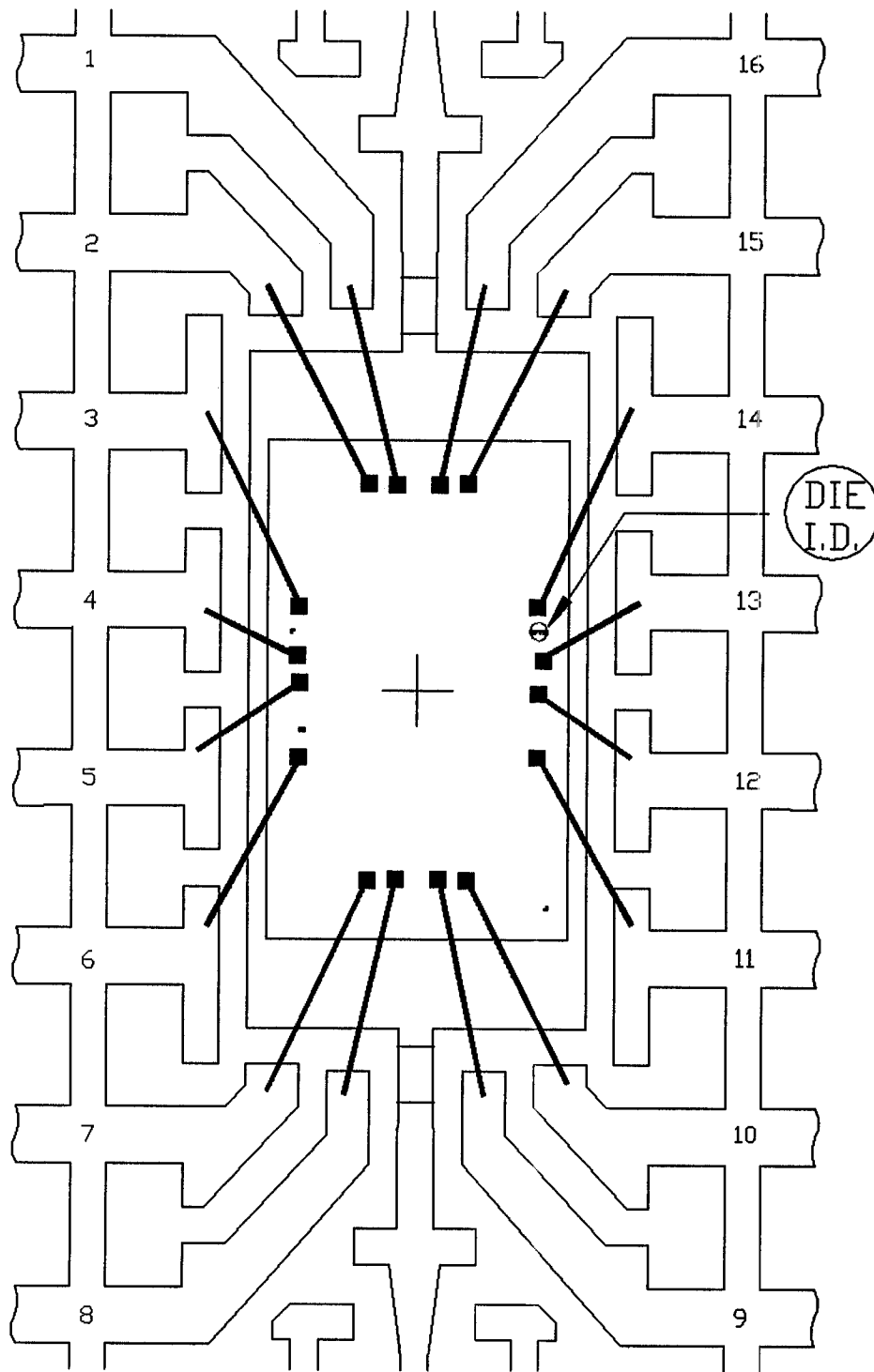

PKG.CODE: S16-5

CAV./PAD SIZE:  
96X190

APPROVALS

DATE

**MAXIM**

BUILDSHEET NUMBER:  
05-0301-0728

REV.:  
A

PKG.  
DESIGN



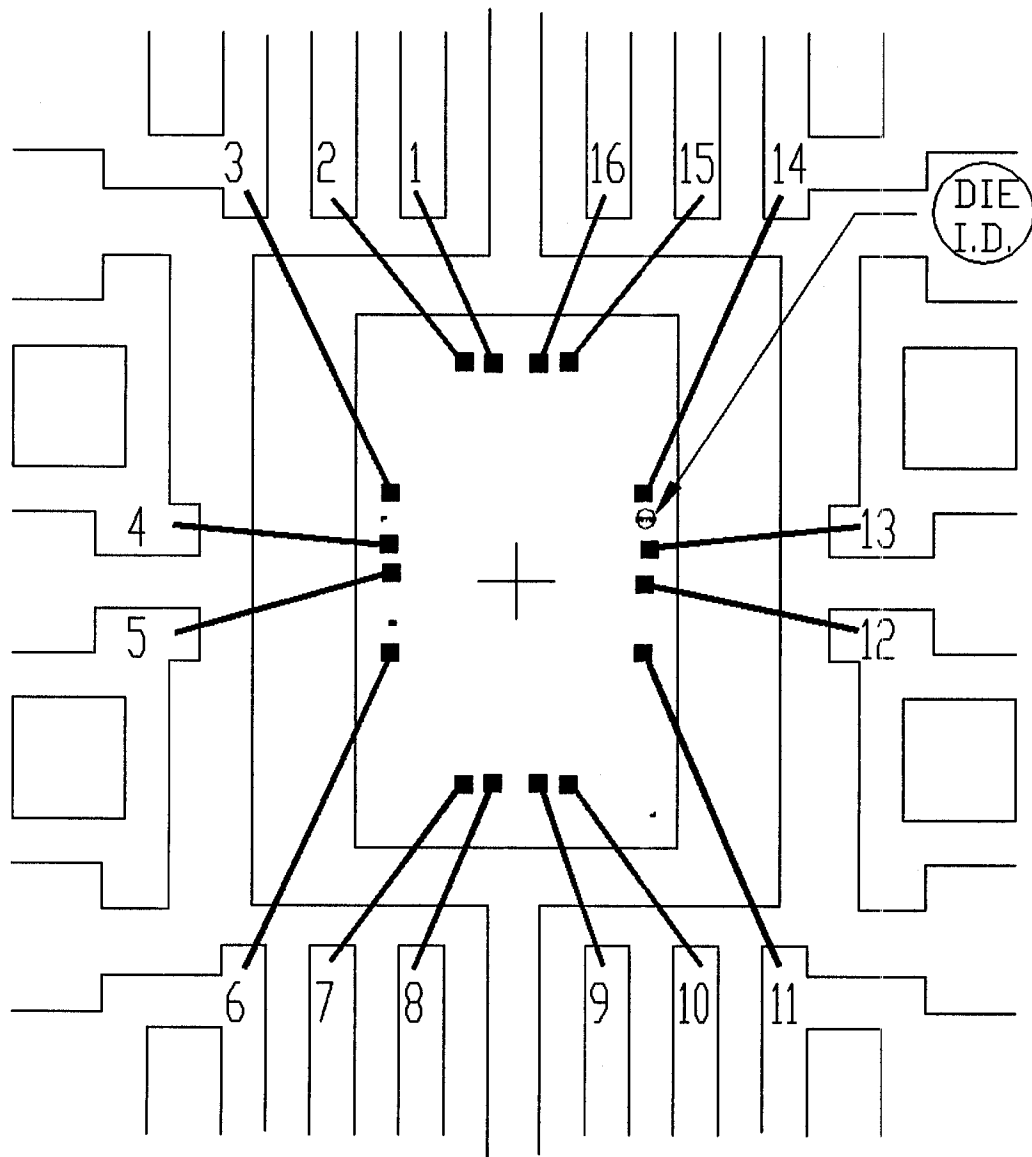

PKG.CODE: P16-2

CAV./PAD SIZE: 140 x 170

APPROVALS

DATE

**MAXIM**

BUILDSHEET NUMBER:  
05--0301-0727

REV.:  
A

PKG.  
DESIGN

