

RELIABILITY REPORT
FOR
MAX1687Exx
PLASTIC ENCAPSULATED DEVICES

September 18, 2002

MAXIM INTEGRATED PRODUCTS

120 SAN GABRIEL DR.

SUNNYVALE, CA 94086

Written by



Jim Pedicord
Quality Assurance
Reliability Lab Manager

Reviewed by



Bryan J. Preeshl
Quality Assurance
Executive Director

Conclusion

The MAX1687 successfully meets the quality and reliability standards required of all Maxim products. In addition, Maxim's continuous reliability monitoring program ensures that all outgoing product will continue to meet Maxim's quality and reliability standards.

Table of Contents

| | |
|-----------------------------------|--------------------------------------|
| I.Device Description | V.Quality Assurance Information |
| II.Manufacturing Information | VI.Reliability Evaluation |
| III.Packaging Information | IV.Die Information |
| |Attachments |

I. Device Description

A. General

The MAX1687 step-up DC-DC converter delivers up to 2W from a single Li-Ion or three NiMH cells. The device is ideal for burst-load applications such as GSM cell phones and wireless LANs, where the RF power amplifiers require short, high current bursts. The MAX1687 reduces battery surge current by slowly charging a reservoir capacitor, which supplies the necessary peak energy for the load current burst. As a result, the peak battery current is limited, thus maximizing battery life and minimizing battery voltage sag and transient dips.

An internal synchronous rectifier provides over 90% conversion efficiency and eliminates the need for an external Schottky diode. A logic shutdown mode reduces the shutdown current to only 3 μ A. The device can be disabled during current bursts (RF transmit mode) to eliminate switching noise.

The switching frequency of the MAX1687, controlled by the selected inductor, can exceed 1MHz. Two external resistors set the output voltage from 1.25V to 6V. The MAX1687 controls peak battery current. The MAX1687 is available in thin 16-pin TSSOP (1.1mm max height) or standard 8-pin SO packages.

B. Absolute Maximum Ratings

| <u>Item</u> | <u>Rating</u> |
|--|-----------------|
| IN, ON, LX1, CHG, LIM, FB, OUT, REF to GND | -0.3V to +7V |
| LX2 to GND | -0.3V to +8V |
| IN, LX1 Average Current | 1A |
| Operating Temperature Range | -40°C to +85°C |
| Storage Temperature Range | -65°C to +150°C |
| Lead Temperature (soldering, 10sec) | +300° C |
| Continuous Power Dissipation (TA = +70°C) | |
| 16-Lead TSSOP | 457mW |
| 8-Lead SO | 471mW |
| Derates above +70°C | |
| 16-Lead TSSOP | 5.7mW/°C |
| 8-Lead SO | 5.88mW/°C |

II. Manufacturing Information

- A. Description/Function: Step-Up DC-DC Converter with Precise, Adaptive Current Limit for GSM
- B. Process: S12 (Standard 1.2 micron silicon gate CMOS)
- C. Number of Device Transistors: 1920
- D. Fabrication Location: California or Oregon, USA
- E. Assembly Location: Philippines or Thailand
- F. Date of Initial Production: October, 1998
- G.

III. Packaging Information

- | | | |
|--|--------------------------|--------------------------|
| A. Package Type: | 8-Pin SO | 16-Pin TSSOP |
| B. Lead Frame: | Copper | Copper |
| C. Lead Finish: | Solder Plate | Solder Plate |
| D. Die Attach: | Silver-filled Epoxy | Silver-filled Epoxy |
| E. Bondwire: | Gold (1.3 mil dia.) | Gold (1.3 mil dia.) |
| F. Mold Material: | Epoxy with silica filler | Epoxy with silica filler |
| G. Assembly Diagram: | # 05-1101-0083 | # 05-1101-0082 |
| H. Flammability Rating: | Class UL94-V0 | |
| I. Classification of Moisture Sensitivity per JEDEC standard JESD22-112: | Level 1 | |

IV. Die Information

- A. Dimensions: 85 x 130 mils
- B. Passivation: $\text{Si}_3\text{N}_4/\text{SiO}_2$ (Silicon nitride/ Silicon dioxide)
- C. Interconnect: Aluminum/Si (Si = 1%)
- D. Backside Metallization: None
- E. Minimum Metal Width: 1.2 microns (as drawn)
- F. Minimum Metal Spacing: 1.2 microns (as drawn)
- G. Bondpad Dimensions: 5 mil. Sq.
- H. Isolation Dielectric: SiO_2
- I. Die Separation Method: Wafer Saw

V. Quality Assurance Information

- A. Quality Assurance Contacts: Jim Pedicord (Reliability Lab Manager)
Bryan Preeshl (Executive Director)
Kenneth Huening (Vice President)
- B. Outgoing Inspection Level: 0.1% for all electrical parameters guaranteed by the Datasheet.
0.1% For all Visual Defects.
- C. Observed Outgoing Defect Rate: < 50 ppm
- D. Sampling Plan: Mil-Std-105D

VI. Reliability Evaluation

A. Accelerated Life Test

The results of the 135°C biased (static) life test are shown in **Table 1**. Using these results, the Failure Rate (λ) is calculated as follows:

$$\lambda = \frac{1}{\text{MTTF}} = \frac{1.83}{192 \times 4389 \times 80 \times 2} \quad (\text{Chi square value for MTTF upper limit})$$

▲
Temperature Acceleration factor assuming an activation energy of 0.8eV

$$\lambda = 13.57 \times 10^{-9}$$

$$\lambda = 13.57 \text{ F.I.T. (60\% confidence level @ 25°C)}$$

This low failure rate represents data collected from Maxim's reliability monitor program. In addition to routine production Burn-In, Maxim pulls a sample from every fabrication process three times per week and subjects it to an extended Burn-In prior to shipment to ensure its reliability. The reliability control level for each lot to be shipped as standard product is 59 F.I.T. at a 60% confidence level, which equates to 3 failures in an 80 piece sample. Maxim performs failure analysis on any lot that exceeds this reliability control level. Attached Burn-In Schematic (Spec. # 06-5353) shows the static Burn-In circuit. Maxim also performs quarterly 1000 hour life test monitors. This data is published in the Product Reliability Report (**RR-1M**).

B. Moisture Resistance Tests

Maxim pulls pressure pot samples from every assembly process three times per week. Each lot sample must meet an LTPD = 20 or less before shipment as standard product. Additionally, the industry standard 85°C/85%RH testing is done per generic device/package family once a quarter.

C. E.S.D. and Latch-Up Testing

The PX54 die type has been found to have all pins able to withstand a transient pulse of $\pm 1000\text{V}$ per Mil-Std-883 Method 3015 (reference attached ESD Test Circuit). Latch-Up testing has shown that this device withstands a current of $\pm 250\text{mA}$ and/or $\pm 20\text{V}$.

Table 1
Reliability Evaluation Test Results

MAX1687Exx

| TEST ITEM | TEST CONDITION | FAILURE IDENTIFICATION | PACKAGE | SAMPLE SIZE | NUMBER OF FAILURES |
|-----------------------------------|---|----------------------------------|----------------|--------------------|---------------------------|
| Static Life Test (Note 1) | | | | | |
| | Ta = 135°C Biased Time = 192 hrs. | DC Parameters & functionality | | 80 | 0 |
| Moisture Testing (Note 2) | | | | | |
| Pressure Pot | Ta = 121°C P = 15 psi. RH= 100% Time = 168hrs. | DC Parameters & functionality | SO TSSOP | 77 77 | 0 0 |
| 85/85 | Ta = 85°C RH = 85% Biased Time = 1000hrs. | DC Parameters & functionality | | 77 | 0 |
| Mechanical Stress (Note 2) | | | | | |
| Temperature Cycle | -65°C/150°C 1000 Cycles Method 1010 | DC Parameters | | 77 | 0 |

Note 1: Life Test Data may represent plastic DIP qualification lots.

Note 2: Generic Package/Process data

Attachment #1

TABLE II. Pin combination to be tested. 1/ 2/

| | Terminal A (Each pin individually connected to terminal A with the other floating) | Terminal B (The common combination of all like-named pins connected to terminal B) |
|----|---|---|
| 1. | All pins except V_{PS1} 3/ | All V_{PS1} pins |
| 2. | All input and output pins | All other input-output pins |

1/ Table II is restated in narrative form in 3.4 below.

2/ No connects are not to be tested.

3/ Repeat pin combination I for each named Power supply and for ground

(e.g., where V_{PS1} is V_{DD} , V_{CC} , V_{SS} , V_{BB} , GND, $+V_S$, $-V_S$, V_{REF} , etc).

3.4 Pin combinations to be tested.

- a. Each pin individually connected to terminal A with respect to the device ground pin(s) connected to terminal B. All pins except the one being tested and the ground pin(s) shall be open.
- b. Each pin individually connected to terminal A with respect to each different set of a combination of all named power supply pins (e.g., V_{SS1} , or V_{SS2} or V_{SS3} or V_{CC1} , or V_{CC2}) connected to terminal B. All pins except the one being tested and the power supply pin or set of pins shall be open.
- c. Each input and each output individually connected to terminal A with respect to a combination of all the other input and output pins connected to terminal B. All pins except the input or output pin being tested and the combination of all the other input and output pins shall be open.

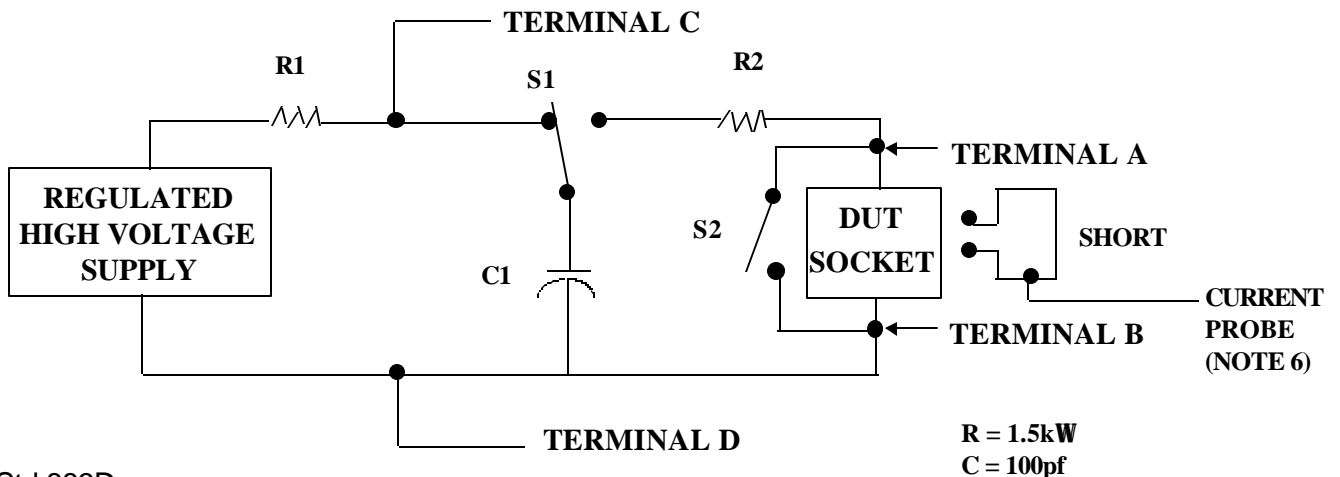

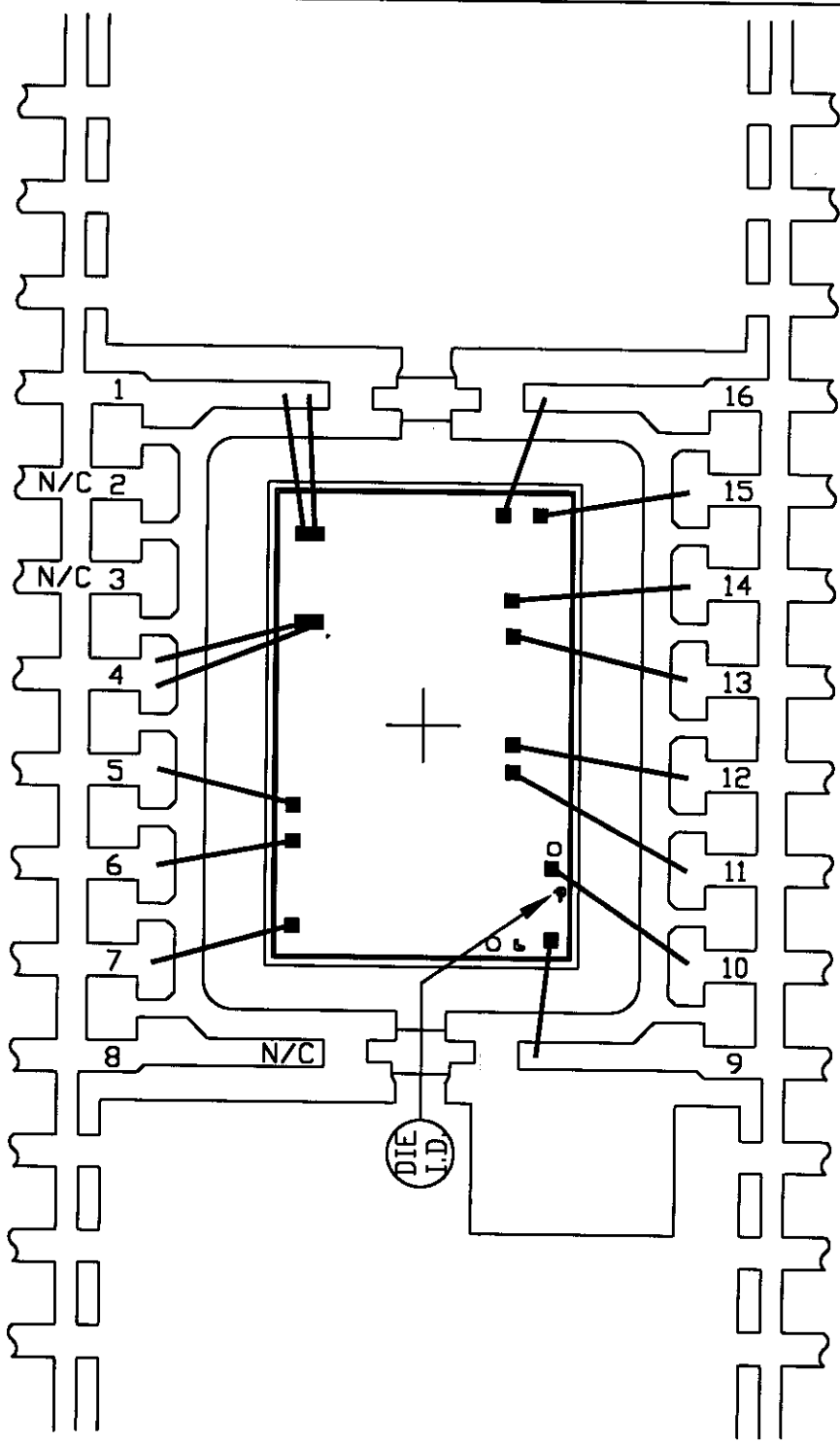

| | | | | | |
|---------------------------|----------------|-----------|------|------------------------------------|------------|
| PKG.CODE: U16-1 | | APPROVALS | DATE | MAXIM | |
| CAV./PAD SIZE: 118X154 | PKG. DESIGN | | | BUILDSHEET NUMBER: 05-1101-0083 | REV.: B |

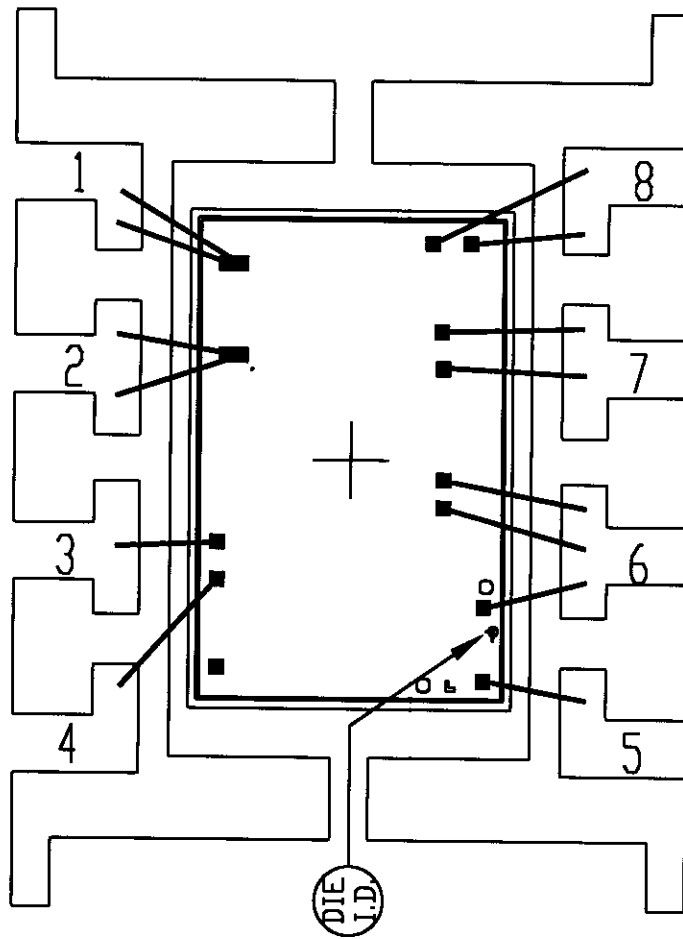

| | | | | | |
|----------------------------|----------------|-----------|------|------------------------------------|------------|
| PKG.CODE: S8-5 | | APPROVALS | DATE | MAXIM | |
| CAV./PAD SIZE: 95 X 155 | PKG. DESIGN | | | BUILDSHEET NUMBER: 05-1101-0082 | REV.: B |

