

LOW COST GENERAL PURPOSE A/D CONVERTERS

ADC-8S, ADC-10Z, ADC-12QZ

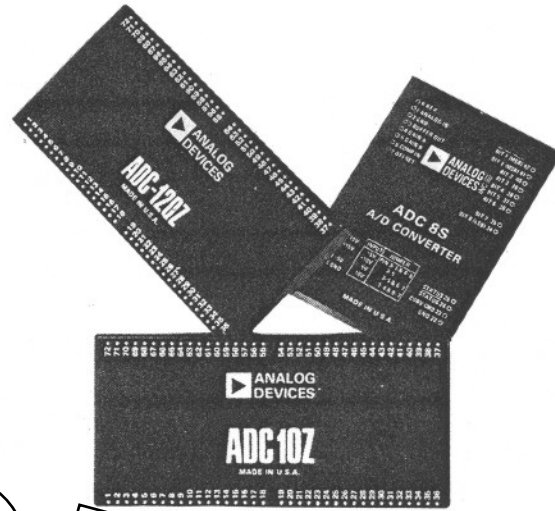

GENERAL DESCRIPTION

These analog-to-digital converters are characterized by low cost, achieved through skilled engineering and high volume, efficient manufacturing. They offer an extremely high performance/cost ratio.

ADC-8S

The ADC-8S is an 8-bit A/D converter of moderate speed that even includes an input buffer. A counter generates a staircase at the output of an internal DAC, the output of which is compared against the signal input. This design requires only simple logic circuitry, helping to hold down cost. Conversion time is proportional to the magnitude of the input signal.

ADC-10Z

The ADC-10Z is a small modular A/D converter that performs a 10-bit conversion in 20 μ s or less. It offers performance and features previously found only in much more expensive converters. It uses the successive approximations conversion technique, and contains an easy-to-use serial output.

ADC-12QZ

The ADC-12QZ is a 12-bit successive approximation type converter that offers reasonable speed and good performance at very low cost. Analog Devices' μ DAC[®] quad current switches and a unique combination of thick-film and hybrid technology has given the ADC-12QZ the basic performance of a much higher priced unit. Like the ADC-10Z, it features an easy-to-use serial output.

**BLOCK DIAGRAM
ADC-10Z**

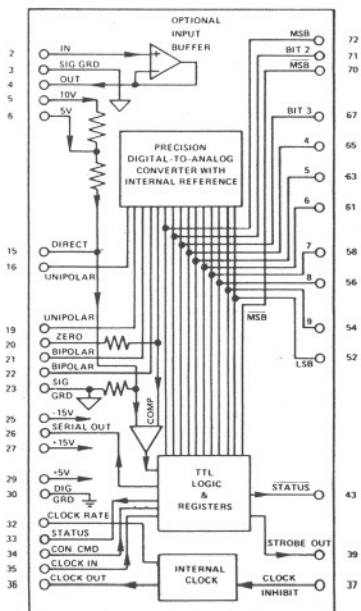

**BLOCK DIAGRAM
ADC-12QZ**

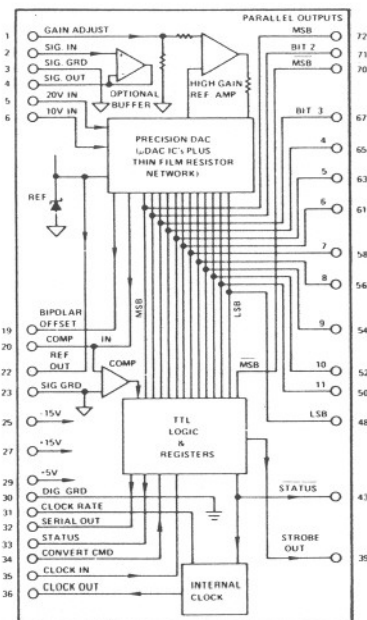

SPECIFICATION SUMMARY (Typical @ +25°C unless otherwise noted)

Model	ADC-8S	ADC-10Z	ADC-12QZ
Resolution, Bits	8	10	12
Linearity Error	±½LSB	*	*
Analog Input Ranges ¹ (Volts)	±5, ±10, +5, +10	*	*
Impedance Without Buffer ²	2.5k - 10kΩ	6k - 12kΩ	2.5k - 10kΩ
With Buffer ³	10 ⁸ ohms	10 ⁹ ohms	10 ⁹ ohms
Conversion Time	1ms ⁴	20μs	40μs
Digital Control Inputs & Outputs	TTL/DTL Compatible	*	*
Data Outputs	TTL Positive True	*	*
Output Codes Standard ⁵	BIN, OBN, 2SC	BIN, OBN, 2SC	BIN, OBN, 2SC
Optional	BCD	-	-
Status or Busy Output	"1" during Conversion	*	*
Serial Data Output	No	Yes	Yes
Temperature Coefficient Gain (of Reading)	±60ppm/°C	±40ppm/°C	±30ppm/°C
Zero (Unipolar)	±20ppm/°C	±25ppm/°C	±5ppm/°C
Offset (Bipolar)	±60ppm/°C	±30ppm/°C	±10ppm/°C
Power Required	+15V @ 28mA -15V @ 28mA +5V @ 120mA	+15V @ 18mA -15V @ 25mA +5V @ 170mA	+15V @ 20mA -15V @ 30mA +5V @ 210mA
Package Style	C-2	C-3	C-3
Package Dimensions	2" x 3" x 0.4"	2" x 4" x 0.4"	2" x 4" x 0.4"
Price (100+)	\$47.	\$67.	\$92.
(1-9)	\$79.	\$99. ³	\$129.

OBSOLETE

¹ Desired input range is selected with jumpers and connections at the module's terminals.

² Input impedance without buffer depends on input range selected, but will be within the indicated limits.

³ Input buffer is standard on ADC-8S, but the unit may be wired for a direct input, if desired. On ADC-10Z and ADC-12QZ, input buffer is optional. In small quantities, add \$20 to price for input buffer. Units with a buffer may be wired for direct input, if desired.

⁴ Conversion time for a full-scale input signal is approximately 1ms. For input signals with a magnitude of less than full-scale, the conversion time is proportionately less.

⁵ Output code is natural binary for unipolar input, but it can be either offset binary or two's complement at the user's option with a bipolar input.

*Specifications same as for ADC-8S.

BLOCK DIAGRAM ADC-8S

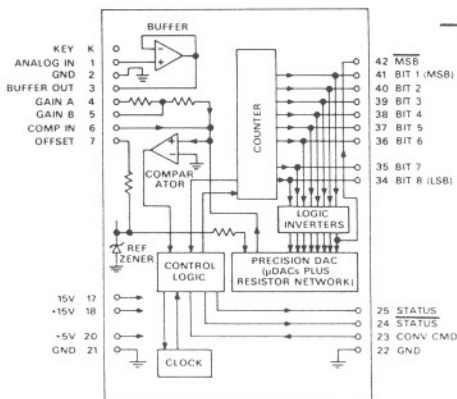

TIMING DIAGRAM: ADC-8S

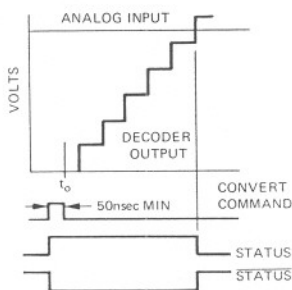

ORDERING GUIDE

ADC-8S	
ADC-8S/BIN	BIN
ADC-8S/BCD	BCD

ADC-10Z	
ADC-10Z-002	NO BUFFER
ADC-10Z-022	BUFFER

ADC-12QZ	
ADC-12QZ-003	NO BUFFER
ADC-12QZ-023	BUFFER