

FEATURES

Input voltage range: 1.2 V to 3.6 V

Bias voltage range: 2.3 V to 5.5 V

Output current range: 0 mA to 350 mA

Output voltage accuracy: $\pm 1\%$

Operating temperature range: $T_J = -40^\circ\text{C}$ to $+125^\circ\text{C}$

GENERAL DESCRIPTION

The EVAL-ADP130 evaluation boards are used to demonstrate the functionality of the ADP130 series of linear regulators.

Simple device measurements such as line and load regulation, dropout, and ground current can be demonstrated with just a single voltage supply, a voltmeter, a current meter, and load resistors.

Full details about the ADP130 regulators are available in the [ADP130](#) data sheet, which should be consulted when using the EVAL-ADP130.

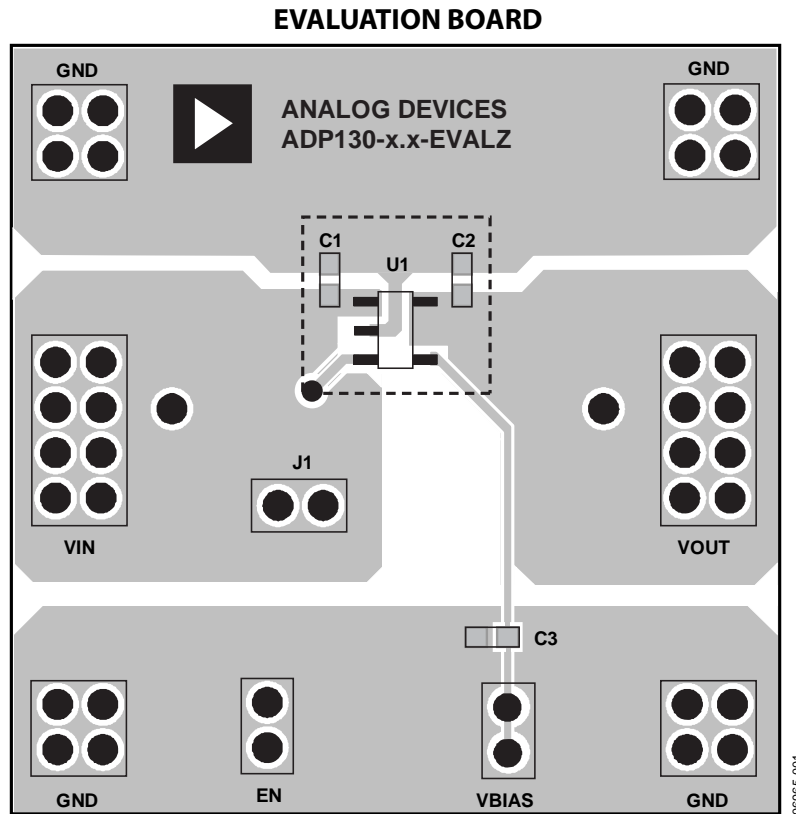

Figure 1.

Rev. 0

Evaluation boards are only intended for device evaluation and not for production purposes. Evaluation boards are supplied "as is" and without warranties of any kind, express, implied, or statutory including, but not limited to, any implied warranty of merchantability or fitness for a particular purpose. No license is granted by implication or otherwise under any patents or other intellectual property by application or use of evaluation boards. Information furnished by Analog Devices is believed to be accurate and reliable. However, no responsibility is assumed by Analog Devices for its use, nor for any infringements of patents or other rights of third parties that may result from its use. Analog Devices reserves the right to change devices or specifications at any time without notice. Trademarks and registered trademarks are the property of their respective owners. Evaluation boards are not authorized to be used in life support devices or systems.

TABLE OF CONTENTS

Features	1	Dropout Voltage	5
General Description	1	Ground and Bias Current Measurement.....	6
Evaluation Board	1	Ground and Bias Current Consumption	6
Revision History	2	Ordering Information.....	8
Evaluation Board Schematic and Hardware	3	Bill of Materials.....	8
Configuration of the Evaluation Boards	4	Ordering Guide	8
Output Voltage Measurement.....	4	ESD Caution.....	8
Line Regulation.....	4		
Load Regulation.....	5		

REVISION HISTORY

8/08—Revision 0: Initial Version

EVALUATION BOARD SCHEMATIC AND HARDWARE

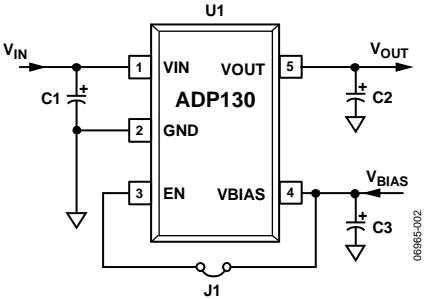

Figure 2. Evaluation Board Schematic

Table 1. Evaluation Board Hardware Components

Component	Function	Description
U1 ¹	Linear regulator	ADP130 low dropout linear regulator.
C1	Input capacitor	A 1 µF input bypass capacitor, which is required for stability and transient performance. Connect C1 from VIN to GND.
C2	Output capacitor	A 1 µF output capacitor, which is required for stability and transient performance. Connect C2 from VOUT to GND.
C3	Bias capacitor	A 1 µF bias bypass capacitor, which is required for transient performance. Connect C3 from VBIAS to GND.
J1	Jumper	The jumper connects EN to VBIAS for automatic startup.

¹ This component varies depending on the evaluation board type ordered.

EVAL-ADP130

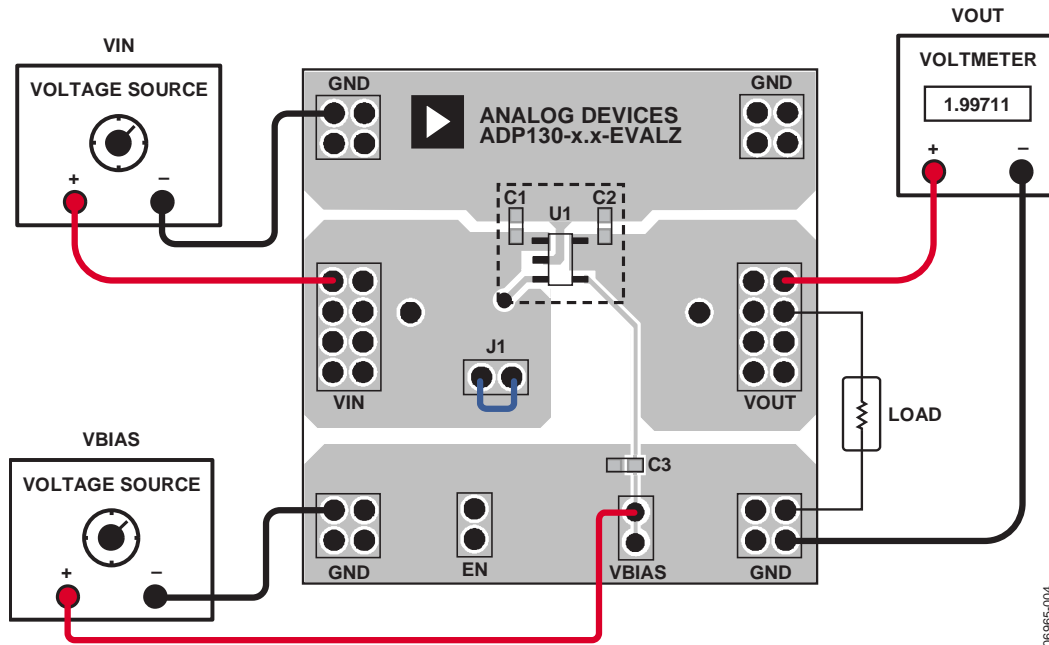

Figure 3. Output Voltage Measurement

CONFIGURATION OF THE EVALUATION BOARDS

The ADP130 evaluation boards come supplied with different components depending on which version is ordered. Components common to all versions are C1, C2, C3, and J1.

OUTPUT VOLTAGE MEASUREMENT

Figure 3 shows how the evaluation board can be connected to a voltage source and a voltage meter for basic output voltage accuracy measurements. A resistor can be used as the load for the regulator. Ensure that the resistor has a power rating adequate to handle the power expected to be dissipated across it. An electronic load can also be used as an alternative. Ensure that the voltage source can supply enough current for the expected load levels.

To connect to the voltage sources and voltage meter, do the following:

1. Connect the negative terminal (-) of the voltage sources to one of the GND pads on the evaluation board.
2. Connect the positive terminal (+) of the VIN voltage source to the VIN pad of the evaluation board.
3. Connect the positive terminal (+) of the VBIAS voltage source to the VBIAS pad of the evaluation board.
4. Connect a load between the VOUT pad and one of the GND pads.
5. Connect the negative terminal (-) of the voltmeter to one of the GND pads, and the positive terminal (+) of the voltmeter to the VOUT pad.
6. The voltage sources can now be turned on. If J1 is inserted (this connects EN to VBIAS for automatic startup), the regulator powers up.

If the load current is large, the user needs to connect the voltage meter as close as possible to the output capacitor to reduce the effects of IR drops.

LINE REGULATION

For line regulation measurements, the output of the regulator is monitored while its input is varied. For good line regulation, the output must change as little as possible with varying input levels. To ensure the device is not in dropout during this measurement, V_{IN} must be varied between V_{OUT} nominal + 0.5 V (or 2.3 V, whichever is greater) and V_{IN} maximum. For example, for an ADP130 with fixed 1.8 V output, V_{IN} needs to be varied between 2.3 V and 5.5 V. This measurement can be repeated under different load conditions. Figure 4 shows the typical line regulation performance of an ADP130 with fixed 1.8 V output.

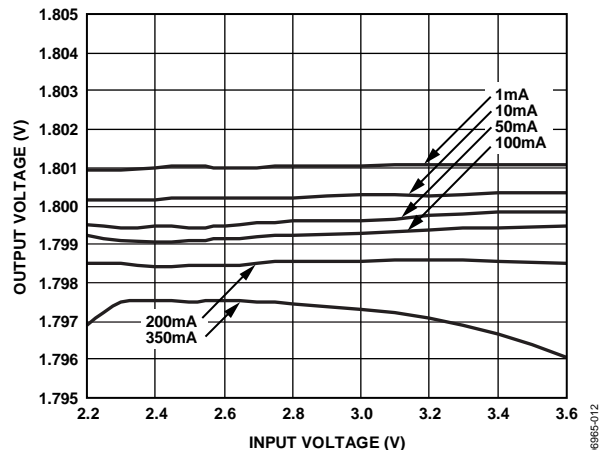

Figure 4. Output Voltage vs. Input Voltage

LOAD REGULATION

For load regulation measurements, the output of the regulator is monitored while the load is varied. For good load regulation, the output must change as little as possible with varying load. The input voltage must be held constant during this measurement. The load current can be varied from 0 mA to 350 mA. Figure 5 shows the typical load regulation performance of an ADP130 with fixed 1.8 V output for an input voltage of 3.6 V.

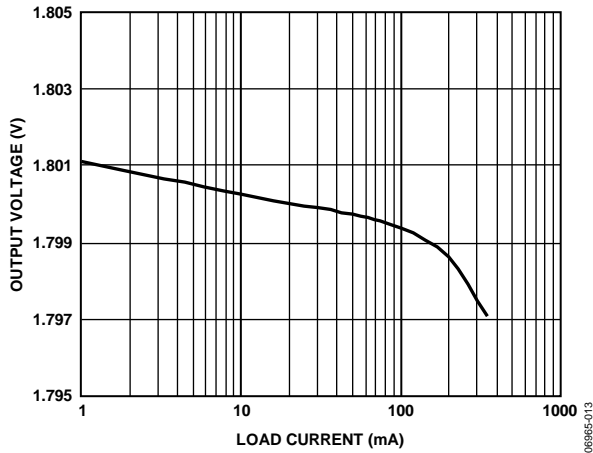

Figure 5. Output Voltage vs. Load Current

DROPOUT VOLTAGE

Dropout voltage can be measured using the configuration shown in Figure 3. Dropout voltage is defined as the input-to-output voltage differential when the input voltage is set to the nominal output voltage, which applies only for output voltages above 1.6 V. Dropout voltage increases with larger loads. For more accurate measurements, a second voltage meter can be used to monitor the input voltage across the input capacitor. The input supply voltage may need to be adjusted to account for IR drops, especially if large load currents are used. Figure 6 shows a typical curve of dropout voltage measurements with different load currents.

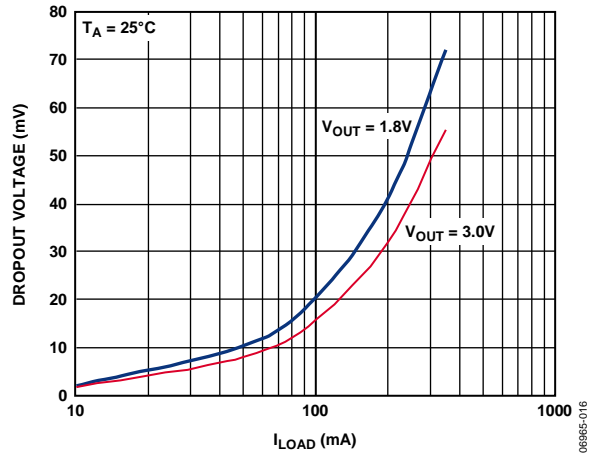

Figure 6. Dropout Voltage vs. Load Current

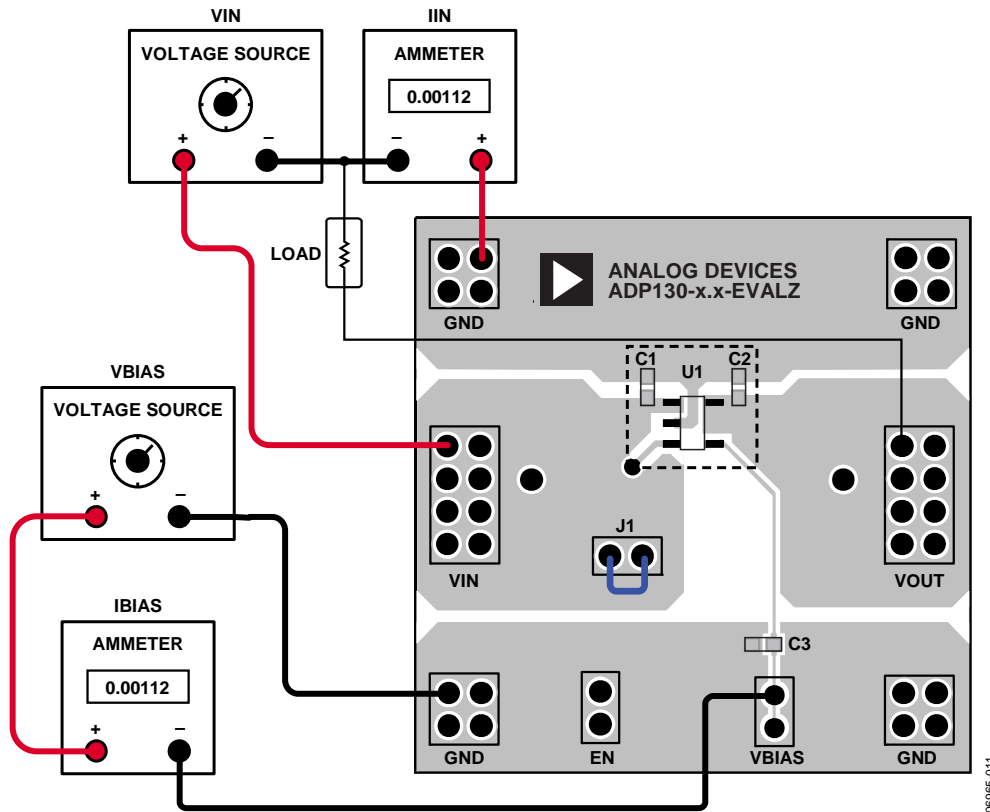

Figure 7. Ground and Bias Current Measurement

GROUND AND BIAS CURRENT MEASUREMENT

Figure 7 shows how the evaluation board can be connected to voltage sources and ammeters for ground and bias current measurements. A resistor can be used as the load for the regulator. Ensure that the resistor has a power rating adequate to handle the power expected to be dissipated across it. An electronic load can be used as an alternative. Ensure that the voltage source used can supply enough current for the expected load levels.

To connect to voltage sources and ammeters, do the following:

1. Connect the positive terminal (+) of the VIN voltage source to one of the VIN pads on the evaluation board.
2. Connect the negative terminal (-) of the VIN voltage source to the negative terminal (-) of the IIN ammeter.
3. Connect the positive terminal (+) of the IIN ammeter to one of the GND pads on the evaluation board.
4. Connect the positive terminal (+) of the VBIAS voltage source to the positive terminal (+) of the IBIAS ammeter.
5. Connect the negative terminal (-) of the IBIAS ammeter to the VBIAS pad on the evaluation board.
6. Connect the negative terminal (-) of the VBIAS voltage source to one of the GND pads on the evaluation board.
7. Connect a load between the VOUT pad of the evaluation board and the negative terminal (-) of the VIN voltage source.
8. The voltage sources can now be turned on. If J1 is inserted (this connects EN to VBIAS for automatic startup), the regulator powers up.

GROUND AND BIAS CURRENT CONSUMPTION

Ground and bias current measurements are a way of determining how much current the internal circuits of the regulator are consuming, while performing the regulation function. To be efficient, the regulator needs to consume as little current as possible. Typically, the regulator uses the maximum current when supplying its largest load level (350 mA). Figure 8 shows the typical ground current consumption for various load levels at $V_{IN} = 3.6$ V.

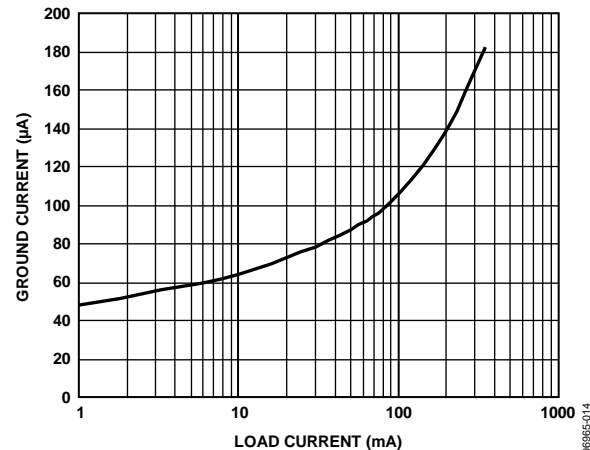

Figure 8. Ground Current vs. Load Current

Figure 9 shows the typical bias current consumption for various load levels at $V_{IN} = 3.6\text{ V}$ and $V_{BIAS} = 5\text{ V}$.

When the device is disabled ($EN = GND$), ground current drops to less than $1\text{ }\mu\text{A}$.

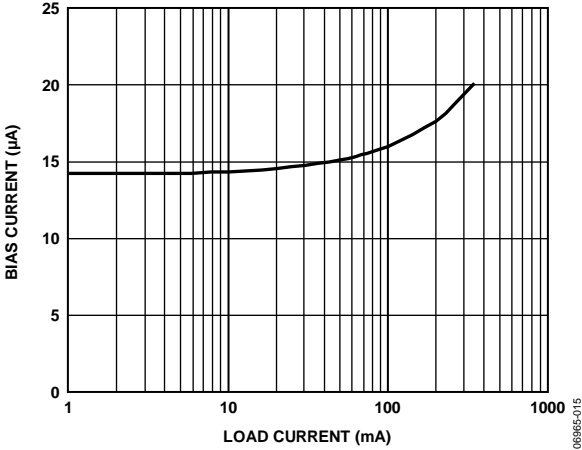

Figure 9. Bias Current vs. Load Current

EVAL-ADP130

ORDERING INFORMATION

BILL OF MATERIALS

Table 2.

Qty	Reference Designator	Description	Manufacturer/Vendor	Vendor Part No.
3	C1, C2, C3	Capacitor, MLCC, 1 μ F, 10 V, 0402, X5R	Murata or equivalent	GRM155R61A105KE15
1	J1	Header, single, STR, 2 pins	Digi-Key Corp.	S1012E-36-ND
1	U1	IC, LDO regulator	Analog Devices, Inc.	ADP1306AUJZ-2.5-R7 ADP1306AUJZ-1.8-R7 ADP1306AUJZ-1.5-R7 ADP1306AUJZ-1.2-R7 ADP1306AUJZ-0.8-R7

ORDERING GUIDE

Model	Output Voltage (V)	Description
ADP130-2.5-EVALZ ¹	2.5	ADP130 Fixed 2.5 V Output Evaluation Board
ADP130-1.8-EVALZ ¹	1.8	ADP130 Fixed 1.8 V Output Evaluation Board
ADP130-1.5-EVALZ ¹	1.5	ADP130 Fixed 1.5 V Output Evaluation Board
ADP130-1.2-EVALZ ¹	1.2	ADP130 Fixed 1.2 V Output Evaluation Board
ADP130-0.8-EVALZ ¹	0.8	ADP130 Fixed 0.8 V Output Evaluation Board

¹ Z = RoHS Compliant Part.

ESD CAUTION

	ESD (electrostatic discharge) sensitive device. Charged devices and circuit boards can discharge without detection. Although this product features patented or proprietary protection circuitry, damage may occur on devices subjected to high energy ESD. Therefore, proper ESD precautions should be taken to avoid performance degradation or loss of functionality.
---	---