

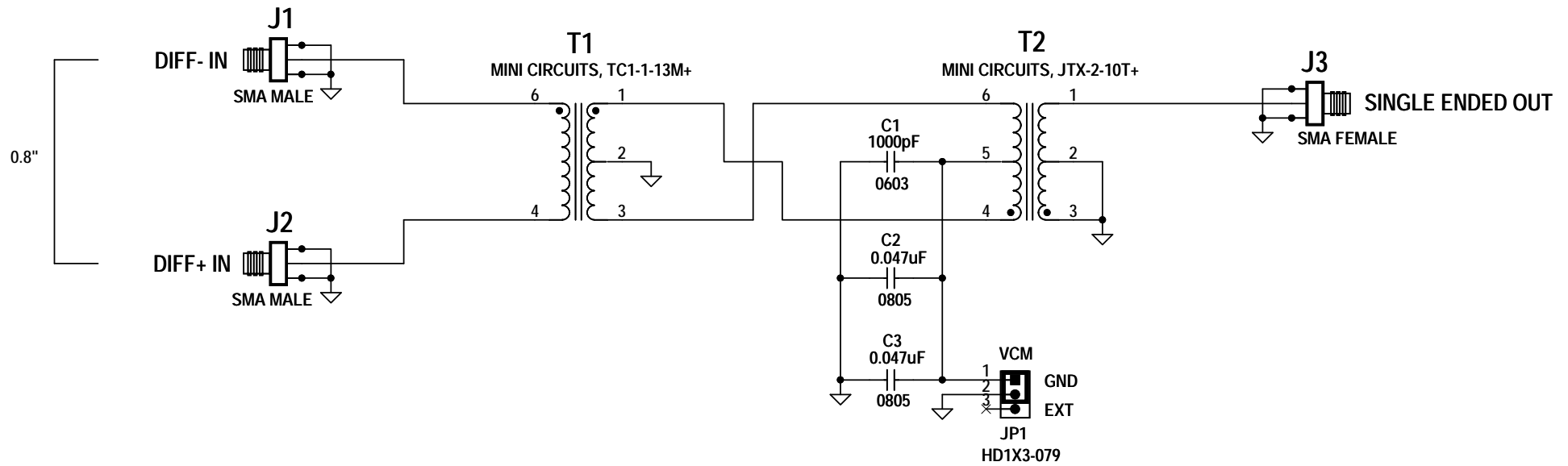

REVISION HISTORY				
ECO	REV	DESCRIPTION	APPROVED	DATE
-	1	PRODUCTION	CLARENCE M.	08-11-14



**CUSTOMER NOTICE**  
 LINEAR TECHNOLOGY HAS MADE A BEST EFFORT TO DESIGN A CIRCUIT THAT MEETS CUSTOMER-SUPPLIED SPECIFICATIONS; HOWEVER, IT REMAINS THE CUSTOMER'S RESPONSIBILITY TO VERIFY PROPER AND RELIABLE OPERATION IN THE ACTUAL APPLICATION. COMPONENT SUBSTITUTION AND PRINTED CIRCUIT BOARD LAYOUT MAY SIGNIFICANTLY AFFECT CIRCUIT PERFORMANCE OR RELIABILITY. CONTACT LINEAR TECHNOLOGY APPLICATIONS ENGINEERING FOR ASSISTANCE.

THIS CIRCUIT IS PROPRIETARY TO LINEAR TECHNOLOGY AND SUPPLIED FOR USE WITH LINEAR TECHNOLOGY PARTS.

APPROVALS	
PCB DES.	KIM T.
APP ENG.	CLARENCE M.
SCALE = NONE	



**LINEAR TECHNOLOGY**

1630 McCarthy Blvd.  
 Milpitas, CA 95035  
 Phone: (408)432-1900 www.linear.com  
 Fax: (408)434-0507  
 LTC Confidential-For Customer Use Only

TITLE: SCHEMATIC

**DIFFERENTIAL TO SINGLE ENDED ADAPTOR**

SIZE N/A	IC NO. LTC2000 DAUGHTER BOARD DEMO CIRCUIT 2233A	REV. 1
DATE: Monday, August 11, 2014		SHEET 1 OF 1