

Quad-Channel, ASIL D-Compliant Automotive Camera Power Protectors

MAX25086–MAX25089

General Description

The MAX25086–MAX25089 quad-channel, camera power protector ICs deliver up to 1.2A constant load current to each of their four output channels. Each output is individually protected from short-to-battery, short-to-ground, and overcurrent conditions. The ICs operate from a 3V to 16V camera supply with input UV/OV protection. The input-to-output voltage drop is only 120mV (typ) at 600mA.

The ICs provide an enable input and I²C interface to configure thresholds and read the diagnostic status of the device. The on-chip ADC enables reading of the current through each active channel as well as input and output voltages.

The MAX25086–MAX25089 includes overtemperature shutdown and overcurrent limiting on each output channel separately and provides unique fault diagnostics. All devices are designed to operate over the -40°C to +125°C ambient temperature range.

The MAX25087 and MAX25089 are ASIL D-compliant.

Applications

- Power-over-Coax for Radar and Camera Modules
- Remote Load Protection

Benefits and Features

- Small Solution
 - Up to Four 1.2A Protection Switches
 - 3V to 16V Input Supply
 - 28V Short-to-Battery Isolation ($V_{OUT} - V_{IN}$)
 - Adjustable Current Limit (100mA to 1.44A)
 - Independent Limit per Channel
 - Onboard 8-Bit ADC
 - Parallel Multiple Channels for Higher Current
 - Selectable I²C Addresses
 - Small (3.5mm x 3.5mm), 16-Pin FC2QFN Package
- Precision
 - ±5% Current-Limit Accuracy
 - Selectable Soft-Start
 - Selectable Soft-Shutdown
 - 6µA Shutdown Current
 - 120mV Drop at 600mA
- Designed for Safety Applications
 - ASIL D Compliant
 - Short to V_{BAT}/GND/OPEN Diagnostics
 - Differential Output Overvoltage Diagnostics
 - Input UV/OV Diagnostics
 - Voltage and Current Readings through I²C
 - Autoretry on Fault
 - AEC-Q100, -40°C to +125°C

Typical Application Diagram

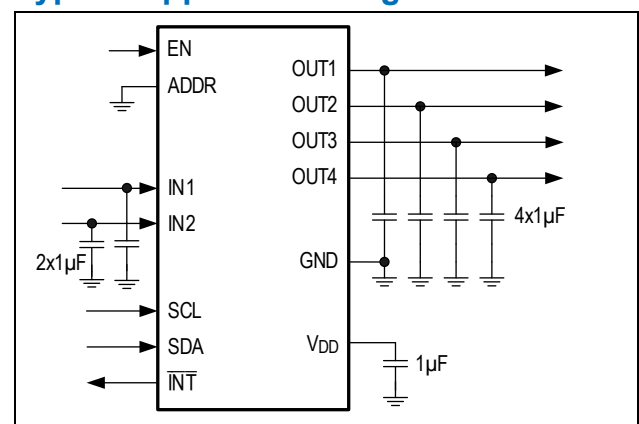

Visit [Web Support](#) to complete the nondisclosure agreement (NDA) required to receive additional product information.

