

MAX22208**65V, 3.8A Quad Half H-Bridge Drivers with
Integrated Current Sense****General Description**

The MAX22208 provides four individually controllable 65V, 3.8A_{MAX} half H-bridge drivers. It can be used to drive four solenoids, two brushed DC motors, one single stepper motor, or a combination of different loads.

The power FETs have very low impedance, resulting in high driving efficiency and low heat dissipation. The typical total R_{ON} (high side plus low side) is 0.3Ω (typ).

Each half bridge can be individually pulse-width modulation (PWM)-controlled with two logic inputs (DIN₋, EN₋).

The MAX22208 integrates non-dissipative current sensing, which eliminates the bulky external power resistors normally required for this function, resulting in a dramatic space and power saving compared with mainstream applications based on the external sense resistor.

A current proportional to the internally-sensed load current is output to the external current-monitor pins (ISEN₋). By connecting an external resistor to these pins, a voltage proportional to the motor current is generated. The voltage drop across the external resistors can be input into the controller ADC whenever the control algorithm requires the current/torque information.

The maximum output current per half H-bridge is I_{MAX} = 3.8A and is limited by the overcurrent protection (OCP) circuit. This current can be driven for very short transients and aims to effectively drive small capacitive loads.

The maximum RMS current per H-bridge is I_{RMS} = 2A. Since this current is limited by thermal considerations, the actual maximum RMS current depends on the thermal characteristic of the application (PCB ground planes, heatsinks, forced air ventilation, etc.).

The MAX22208 features overcurrent protection (OCP), thermal shutdown (TSD), and undervoltage lockout (UVLO). An active-low, open-drain $\overline{\text{FAULT}}$ pin is activated every time a fault condition is detected.

During TSD and UVLO, the driver outputs are three-stated until normal operating conditions are restored.

The MAX22208 is available in a small, 5mm x 7mm, 38-pin TQFN and 4.4mm x 9.7mm, 38-pin TSSOP package.

Applications

- Brushed DC Motor Driver
- Stepper Motor Driver
- Solenoid Driver
- Latched Valves

Benefits and Features

- Four Independent Half H-Bridge Drivers
 - 65V Maximum Operating Voltage
 - 0.3Ω (typ) R_{ON} (High Side + Low Side) at T_A = +25°C
 - Fully Independent Half-Bridge Control
- Current Rating per H-Bridge (T_A = +25°C):
 - I_{MAX} = 3.8A (Impulse Current for Driving Capacitive Loads)
 - I_{RMS} = 2A
- Integrated Current Sensing (ICS) Eliminates External Bulky Resistors and Improves Efficiency
- Current-Sense Output Monitor
- Fault Indicator Pin ($\overline{\text{FAULT}}$)
 - Overcurrent Protection for Each Individual Channel (OCP)
 - Undervoltage Lockout (UVLO)
 - Thermal Shutdown T_{SD} = +155°C
- 5mm x 7mm, 38-Pin TQFN and 4.4mm x 9.7mm, 38-Pin TSSOP Packages

Ordering Information appears at end of data sheet.

19-101619; Rev 1; 5/24

© 2024 Analog Devices, Inc. All rights reserved. Trademarks and registered trademarks are the property of their respective owners.

One Analog Way, Wilmington, MA 01887 U.S.A. | Tel: 781.329.4700 | © 2024 Analog Devices, Inc. All rights reserved.

Simplified Block Diagram

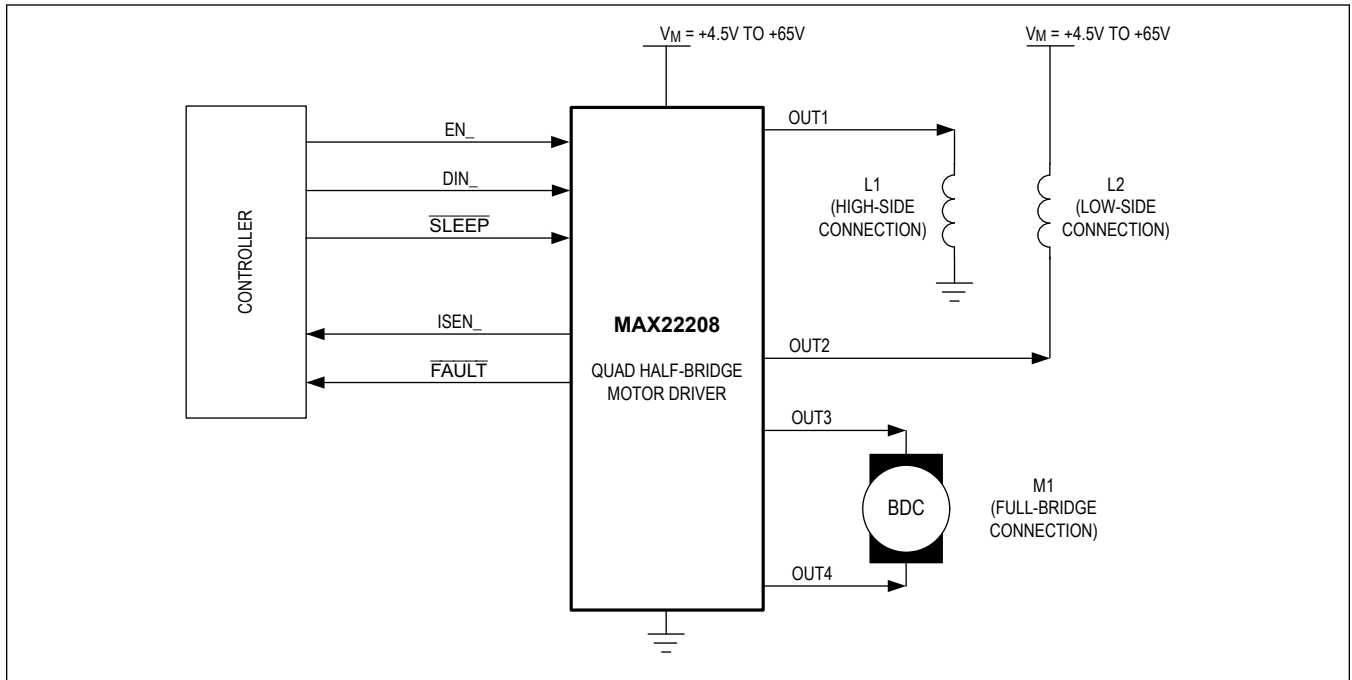

TABLE OF CONTENTS

General Description	1
Applications	1
Benefits and Features	1
Simplified Block Diagram	2
Absolute Maximum Ratings	6
Package Information	6
38-Pin TSSOP (9.7mm x 4.4mm)	6
38-Pin TQFN (5mm x 7mm)	6
Electrical Characteristics	7
Typical Operating Characteristics	9
Pin Configurations	10
TQFN Pin Configuration	10
TSSOP Pin Configuration	10
Pin Description	11
Functional Diagrams	12
Detailed Description	13
Sleep Mode (SLEEP Pin)	13
PWM Control	13
Current-Sense Output (ISEN_)—Current Monitor	13
Fault Protection	14
Overcurrent Protection (OCP)	14
Thermal Shutdown	14
Undervoltage-Lockout Protection (UVLO)	14
Applications Information	15
Typical Application Circuits	17
Application Diagram	17
Ordering Information	18
Revision History	19

MAX22208

65V, 3.8A Quad Half H-Bridge Drivers with
Integrated Current Sense

LIST OF FIGURES

Figure 1. MAX22208 Recommended Layout 16

MAX22208

65V, 3.8A Quad Half H-Bridge Drivers with
Integrated Current Sense

LIST OF TABLES

Table 1. MAX22208 Truth Table 13

Absolute Maximum Ratings

V_M to GND	-0.3V to +70V	ISEN_ to GND.....	-0.3V to min (+2.2V, $V_{DD} + 0.3V$)
V_{DD} to GND.....	-0.3V to min (+2.2V, $V_M + 0.3V$)	DIN_ to GND.....	-0.3V to 6V
PGND to GND	-0.3V to +0.3V	EN_ to GND.....	-0.3V to 6V
OUT_.....	-0.3 to ($V_M + 0.3V$)	SLEEP to GND	-0.3V to min (+70V, $V_M + 0.3V$)
V_{CP} to GND.....	($V_M - 0.3V$) to min (+74V, $V_M + 6V$)	Operating Temperature Range	-40°C to +125°C
CP ₂ to GND	($V_M - 0.3V$) to ($V_{CP} + 0.3V$)	Junction Temperature	+150°C
CP ₁ to GND	-0.3V to ($V_M + 0.3V$)	Storage Temperature Range	-65°C to +150°C
FAULT to GND	-0.3V to 6V	Soldering Temperature (reflow)	+260°C

Stresses beyond those listed under "Absolute Maximum Ratings" may cause permanent damage to the device. These are stress ratings only, and functional operation of the device at these or any other conditions beyond those indicated in the operational sections of the specifications is not implied. Exposure to absolute maximum rating conditions for extended periods may affect device reliability.

Package Information

38-Pin TSSOP (9.7mm x 4.4mm)

Package Code	U38E+3C
Outline Number	21-0714
Land Pattern Number	90-0435
Thermal Resistance, Four-Layer Board:	
Junction to Ambient (θ_{JA})	45°C/W
Junction to Case (θ_{JC})	1°C/W

38-Pin TQFN (5mm x 7mm)

Package Code	T3857-1C
Outline Number	21-0172
Land Pattern Number	90-0076
Thermal Resistance, Single-Layer Board:	
Junction to Ambient (θ_{JA})	38°C/W
Junction to Case (θ_{JC})	1°C/W
Thermal Resistance, Four-Layer Board:	
Junction to Ambient (θ_{JA})	28°C/W
Junction to Case (θ_{JC})	1°C/W

For the latest package outline information and land patterns (footprints), go to [Package Index](#). Note that a "+", "#", or "-" in the package code indicates RoHS status only. Package drawings may show a different suffix character, but the drawing pertains to the package regardless of RoHS status.

Package thermal resistances were obtained using the method described in JEDEC specification JESD51-7, using a four-layer board. For detailed information on package thermal considerations, refer to [Thermal Characterization of IC Packages](#).

Electrical Characteristics

(V_M = from +4.5V to +65V, limits are 100% tested at $T_A = +25^\circ\text{C}$. Limits over the operating temperature range are guaranteed by design and characterization, typical values are at $V_M = 36\text{V}$ and $T_A = +25^\circ\text{C}$.)

PARAMETER	SYMBOL	CONDITIONS	MIN	TYP	MAX	UNITS
POWER SUPPLY						
Supply Voltage Range	V_M		4.5		65	V
Sleep-Mode Current Consumption	I_{VM}	$\overline{\text{SLEEP}}$ = logic low			20	μA
Quiescent Current Consumption	I_{VM}	$\overline{\text{SLEEP}}$ = logic high			5	mA
1.8V Regulator Output Voltage	V_{VDD}	$V_M = +4.5\text{V}$, $I_{LOAD} = 20\text{mA}$		1.8		V
V_{DD} Current Limit	$I_{VDD(LIM)}$	V_{DD} shorted to GND	18			mA
Charge-Pump Voltage	V_{CP}			$V_M + 2.7$		V
LOGIC LEVEL INPUTS/OUTPUTS						
Input Voltage Level—High	V_{IH}		1.2			V
Input Voltage Level—Low	V_{IL}				0.65	V
Input Hysteresis	V_{HYS}			110		mV
Pull-Down Current	I_{PD}	Logic supply (V_L) = +3.3V	16	34	60	μA
Open-Drain Output Logic-Low Voltage	V_{OL}	$I_{LOAD} = 5\text{mA}$			0.4	V
Open-Drain Output Logic-High Leakage Current	I_{OH}	$V_{PIN} = +3.3\text{V}$	-1		+1	μA
$\overline{\text{SLEEP}}$ Voltage Level High	$V_{IH(\overline{\text{SLEEP}})}$		0.9			V
$\overline{\text{SLEEP}}$ Voltage Level Low	$V_{IL(\overline{\text{SLEEP}})}$				0.6	V
$\overline{\text{SLEEP}}$ Pull-Down Input Resistance	$R_{PD(\overline{\text{SLEEP}})}$		0.8	1.5		$\text{M}\Omega$
OUTPUT SPECIFICATIONS						
Output On-Resistance Low-Side	$R_{ON(LS)}$			150	270	$\text{m}\Omega$
Output On-Resistance High-Side	$R_{ON(HS)}$			150	300	$\text{m}\Omega$
Output Leakage	I_{LEAK}	Driver off	-12		+12	μA
Dead Time	t_{DEAD}			100		ns
Output Slew Rate	SR			300		V/ μs
PROTECTION CIRCUITS						
Overcurrent Protection Threshold	I_{OCP}		3.8			A
Overcurrent Protection Blanking Time	t_{OCP}			2.2	3.5	μs
Autoretry OCP Time	t_{RETRY}			3		ms
UVLO Threshold on V_M	V_{UVLO}	V_M rising	3.75	4	4.25	V

Electrical Characteristics (continued)

(V_M = from +4.5V to +65V, limits are 100% tested at $T_A = +25^\circ\text{C}$. Limits over the operating temperature range are guaranteed by design and characterization, typical values are at $V_M = 36\text{V}$ and $T_A = +25^\circ\text{C}$.)

PARAMETER	SYMBOL	CONDITIONS	MIN	TYP	MAX	UNITS
UVLO Threshold on V_M Hysteresis	$V_{UVLOHYS}$			0.12		V
Thermal-Protection Threshold Temperature	T_{SD}	Temperature rising until $\overline{\text{FAULT}}$ pin goes low		+155		$^\circ\text{C}$
Thermal-Protection Temperature Hysteresis	T_{SD_HYST}	Temperature falling until $\overline{\text{FAULT}}$ pin goes high		20		$^\circ\text{C}$
CURRENT-SENSE MONITOR						
ISEN_ Voltage Range	V_{ISEN}	Voltage range at ISEN_ pin	0		1.1	V
Current-Monitor Scaling Factor	KISEN	See the I_{ISEN} output-current equation in the Current-Sense Output (ISEN_) — Current Monitor section		7500		A/A
Settling Time	t_S	$I_{FS} = I_{MAX}$		0.5		μs
FUNCTIONAL TIMING						
Sleep Time	t_{SLEEP}	$\overline{\text{SLEEP}}$ = logic 1 to logic 0 for OUT_ to become three-state		40		μs
Wake-Up Time from Sleep	t_{WAKE}	$\overline{\text{SLEEP}}$ = logic 0 to logic 1 to resume normal operation			2.7	ms
Enable Time	t_{EN}	Time from EN_ pin rising edge to driver on			0.6	μs
Disable Time	t_{DIS}	Time from EN_ pin falling edge to driver off			1.4	μs

Typical Operating Characteristics

($V_M = +4.5V$ to $+60V$; $T_A = +25^\circ C$, unless otherwise noted.)

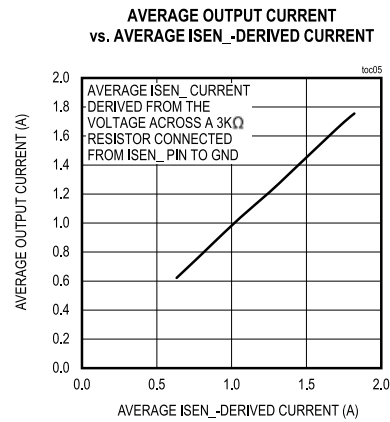
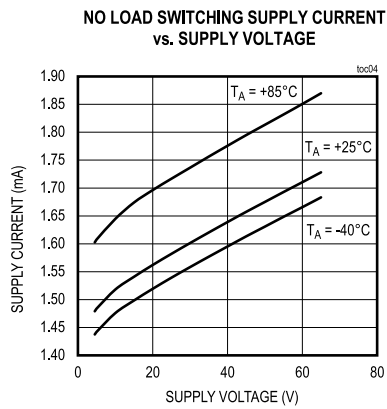
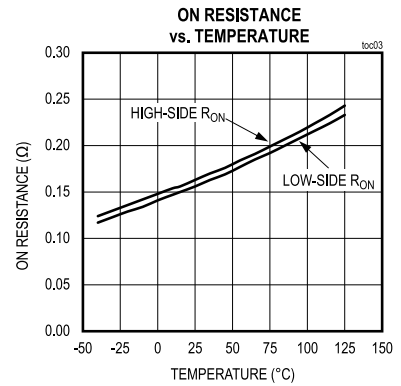
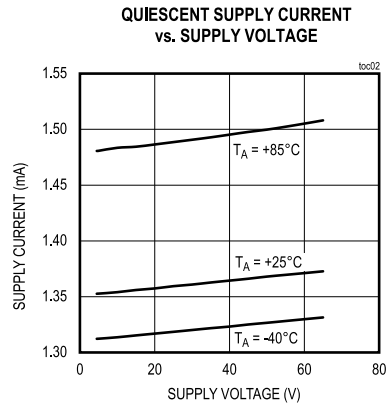
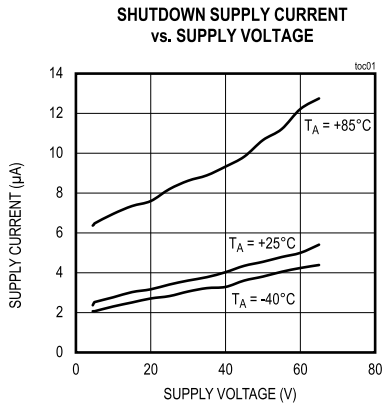

Pin Configurations

TQFN Pin Configuration

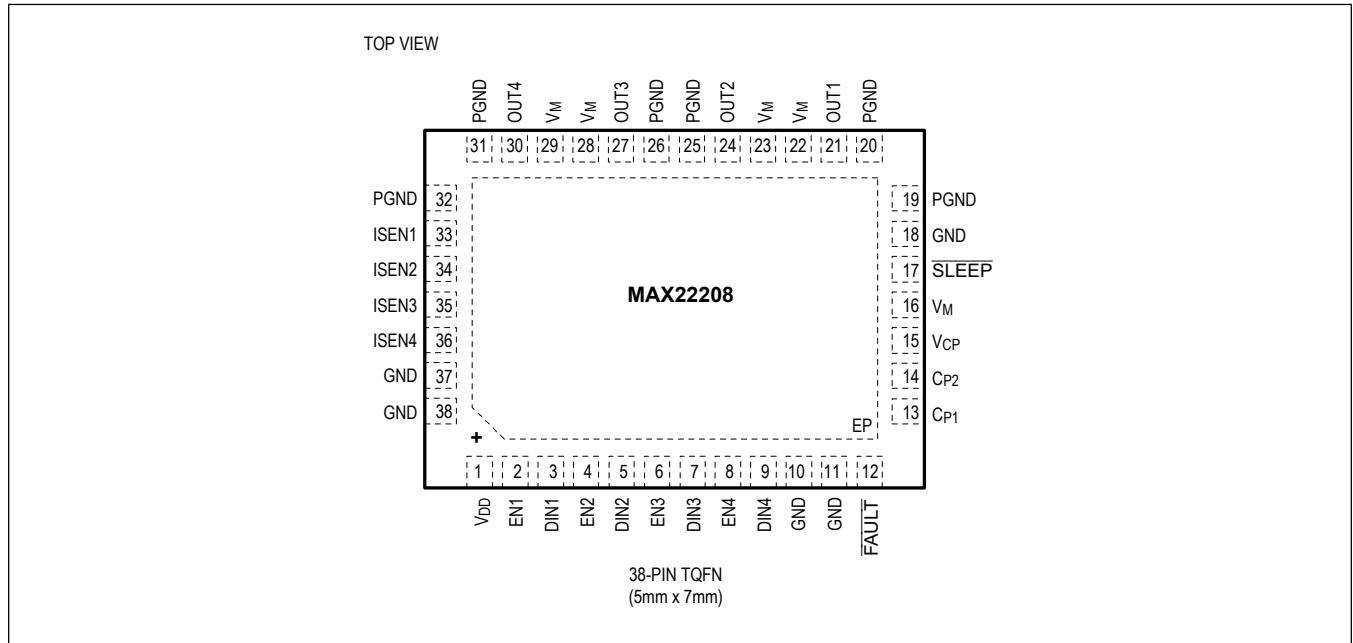

TSSOP Pin Configuration

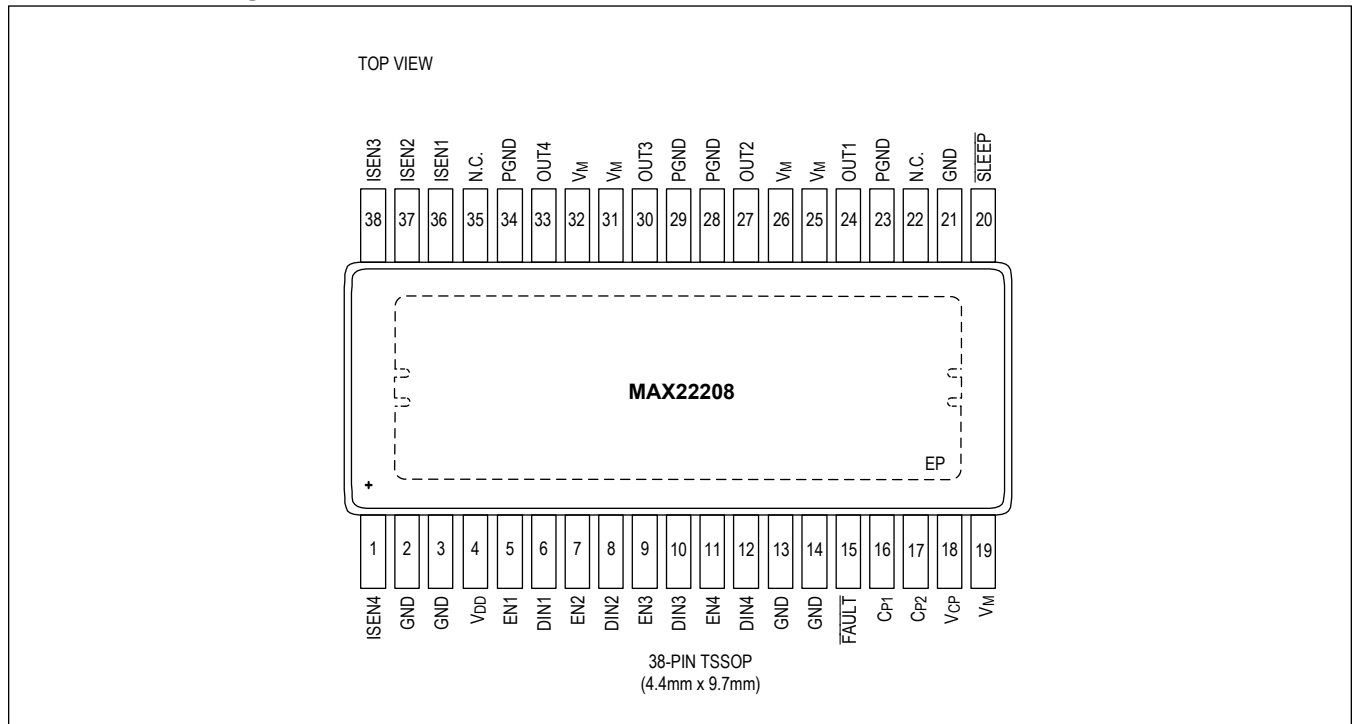

Pin Description

PIN		NAME	FUNCTION	TYPE
TQFN	TSSOP			
16, 22, 23, 28, 29	19, 25, 26, 31, 32	V _M	Supply Voltage Input. Connect at least 1μF surface-mounted device plus 10μF electrolytic bypass capacitors to GND. Higher values can be considered depending on application requirements.	Supply
15	18	V _{CP}	Charge-Pump Output. Connect a 5V, 1μF capacitor between V _{CP} and V _M as close as possible to the device.	Output
13	16	C _{P1}	Charge-Pump Flying Capacitor Pin 1. Connect a V _M -rated 22nF capacitor between C _{P1} and C _{P2} as close as possible to the device.	Output
14	17	C _{P2}	Charge-Pump Flying Capacitor Pin 2. Connect a V _M -rated 22nF capacitor between C _{P1} and C _{P2} as close as possible to the device.	Output
1	4	V _{DD}	1.8V Linear Regulator Output. Bypass V _{DD} to GND with a 5V, 2.2μF capacitor connected close to the device.	Analog Output
17	20	$\overline{\text{SLEEP}}$	Active-Low Sleep Pin.	Logic Input
21, 24, 27, 30	24, 27, 30, 33	OUT1 to OUT4, respectively	Driver Outputs.	Output
12	15	$\overline{\text{FAULT}}$	Active-Low, Open-Drain, Output Fault Indicator. $\overline{\text{FAULT}}$ goes low to indicate that one or more of the protection mechanisms has been activated. Connect a 2kΩ pull-up resistor from FAULT to the microcontroller supply voltage.	Open-Drain Output
33, 34, 35, 36	36, 37, 38, 1	I _{SEN1} to I _{SEN4} , respectively	Current-Sense Output Monitor. Connect a resistor to GND to monitor the voltage generated with an external ADC (see the Current-Sense Output (I_{SEN})—Current Monitor section).	Output
2, 4, 6, 8	5, 7, 9, 11	EN1 to EN4, respectively	Enable Pin. Assert high to enable output drivers.	Logic Input
3, 5, 7, 9	6, 8, 10, 12	DIN1 to DIN4, respectively	CMOS PWM Inputs	Logic Input
10, 11, 18, 37, 38	2, 3, 13, 14, 21	GND	Analog Ground. Connect to ground plane.	GND
19, 20, 25, 26, 31, 32	23, 28, 29, 34	PGND	Power GND. Connect to ground plane.	GND
—	22, 35	N.C.	No Connection	—
EP	EP	EP	Exposed Pad. Connect to GND.	GND

Functional Diagrams

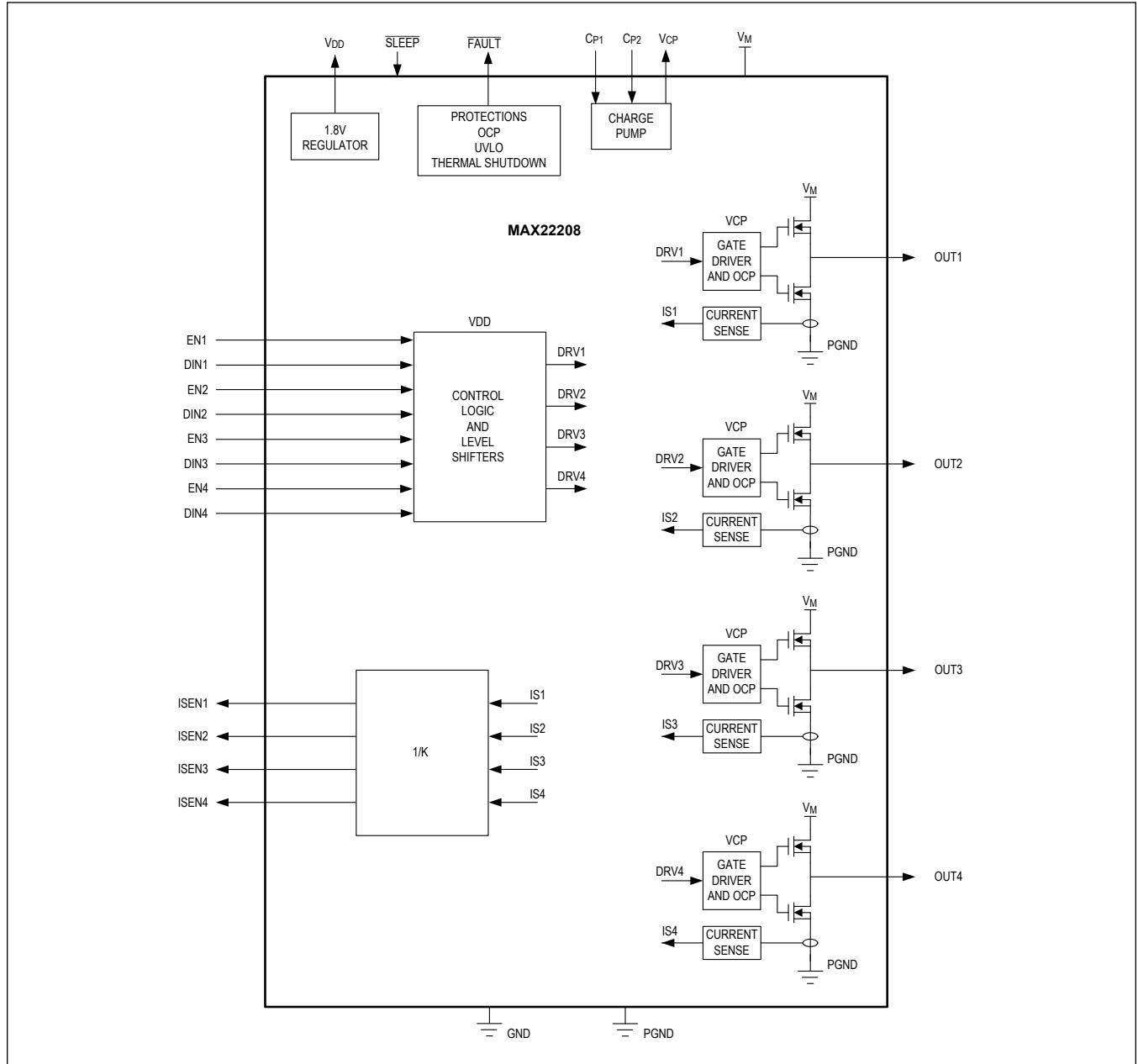

Detailed Description

The MAX22208 provides four individually controllable 65V, 3.8A_{MAX} half H-Bridge drivers. It can be used to drive four solenoids, two brushed DC motors, a single stepper motor, or a combination of different loads.

The power FETs have very low impedance resulting in high driving efficiency and low heat generation. The typical total R_{ON} (high side + low side) is 0.3Ω (typ). Each half-bridge can be PWM controlled by two logic inputs (DIN_ and EN_).

The MAX22208 integrates non-dissipative current sensing which eliminates the bulky external power-sense resistors to reduce space and save power. The internally sensed current is scaled and output to the external current monitor pins (ISEN_), which generate a voltage proportional to the load current when a resistor is connected from the ISEN_ pins to GND. This voltage can be monitored by a microcontroller ADC to get load current and torque information.

The maximum transient output current for each half bridge is I_{MAX} = 3.8A and is limited by overcurrent protection (OCP). This current can be tolerated for short intervals and is aimed to drive small capacitive loads. The maximum RMS current per H-Bridge is I_{RMS} = 2A and is limited by the thermal characteristics of the application such as package and die temperature, PCB ground planes and routing, heatsinks, forced air ventilation, etc.

Sleep Mode ($\overline{\text{SLEEP}}$ Pin)

The $\overline{\text{SLEEP}}$ pin can be driven low to place the device into the lowest power consumption mode possible, with all outputs three-stated, the internal circuits biased off, and the charge pump disabled. A pull-down resistor should be connected between $\overline{\text{SLEEP}}$ and GND to ensure the part is disabled whenever this pin is not actively driven. Driving the $\overline{\text{SLEEP}}$ pin high wakes up the device and returns it to normal mode. t_{WAKE} is 2.7ms (max).

PWM Control

When a half bridge is enabled (EN_ = logic high), the average output voltage is controlled by the corresponding DIN_ logic input. PWM techniques can be used to control the output duty cycle and hence to implement motor speed or solenoid current control.

Setting the EN_ pins at logic low forces the corresponding OUT_ driver pins to enter a high-impedance mode. The EN_ input pins should not be used for PWM control.

Each half-bridge (OUT_) is controlled by two logic inputs (DIN_, EN_). [Table 1](#) shows the control truth table.

Table 1. MAX22208 Truth Table

EN_	DIN_	OUT_	DESCRIPTION
0	X	High-Impedance	Half H-bridge is disabled.
1	0	Low	Low-side FET is driven.
1	1	High	High-side FET is driven.

Current-Sense Output (ISEN_)—Current Monitor

A current proportional to the internally-sensed motor current for each OUT_ is output to the ISEN_ pins for each individual half H-bridge. The integrated current sense is unipolar and the current is sensed on the low-side (LS) FET only. Therefore, the current information is meaningful when the LS FET is on and operates in forward mode.

Under this condition, the ISEN output-current equation applies:

$$I_{\text{ISEN}}(\text{A}) = \frac{I_{\text{OUT}}(\text{A})}{K_{\text{ISEN}}}$$

Where K_{ISEN} represents the current scaling factor between the output current and its replica at the ISEN_ pins. K_{ISEN} is typically 7.5KA/A. For example, if the instantaneous output current is 2A, the current sourced at ISEN is 266μA.

When the LS FET is on in reverse mode, or when the high-side FET is on, the ISEN_ current monitor outputs a zero current.

Connecting an external signal resistor, R_{ISEN}, between each ISEN_ and GND generates a voltage proportional to the

motor current. The voltage drop across R_{ISEN} can be input into an ADC of an external controller in applications in which the motor control algorithm requires the current/torque information. The R_{ISEN} value should be chosen so that the peak voltage meets the ADC full-scale requirement and does not exceed V_{ISEN} (max). The following equation shows the design formula to calculate R_{ISEN} once the ADC full-scale voltage (V_{FS}) and the maximum operating current (I_{MAX}) are known:

$$R_{ISEN}(\Omega) = K_{ISEN} \times \frac{V_{FS}(V)}{I_{MAX}(A)}$$

For example, if the ADC operates up to 1V FS and the maximum operating output current is 2A, then R_{ISEN} is $7500 \times 1V/2A = 3.75K\Omega$.

The R_{ISEN} value also sets the output impedance of the current-sense output circuit. Normally, the input impedance of the ADC is much higher than R_{ISEN} , enabling a direct connection to the ISEN_ pins without signal attenuation, but if a low-input-impedance ADC is used, a pre-amplifier (buffer) is required.

Fault Protection

Overcurrent Protection (OCP)

OCP protects the device against OUT_ short circuits to the rails (supply voltage and ground) or excessive load currents.

The OCP threshold is set at 3.8A minimum. If the output current is greater than the OCP threshold for longer than the deglitch time (OCP blanking time), an OCP event is detected, the half H-bridge is set to high-impedance mode, and the \overline{FAULT} output is driven low to indicate to external circuitry that a fault condition has been detected. The half H-bridge is kept in high-impedance mode for 3ms (typ) before autoretry is initiated when the OUT_ H-bridge is re-enabled according to its current state as defined by EN_ and DIN_. If the overcurrent event or short circuit is still present, this cycle repeats. Otherwise, normal operation resumes. The external circuitry monitoring \overline{FAULT} should take action to avoid prolonged operation under the overcurrent mode as a prolonged OCP autoretry could affect the device reliability.

Thermal Shutdown

If the die temperature exceeds $T_{SD} = +155^{\circ}\text{C}$ (typ), all output pins (OUT1–OUT4) are three-stated and the \overline{FAULT} pin is driven low. The \overline{FAULT} pin remains low and the outputs are placed in three-state mode until the die temperature falls by the hysteresis amount of 20°C (typ), after which the \overline{FAULT} pin is driven high and the outputs are re-enabled.

Undervoltage-Lockout Protection (UVLO)

When the V_M supply voltage is below the UVLO threshold, all OUT_ outputs are three-stated and the \overline{FAULT} pin is driven low. The OUT_ outputs automatically return to their current state (defined by EN_ and DIN_) when the V_M supply voltage exceeds the UVLO threshold (max) and \overline{FAULT} is driven high.

Applications Information

Careful PCB layout is critical to achieve low switching losses and clean, stable operation. Use a multilayer board whenever possible for better noise immunity and power dissipation. Follow these guidelines for good PCB layout:

1. Place supply and charge-pump bypass capacitors close to the IC.
2. Ensure a good connection from the exposed pad to the GND plane by using vias and ground pours to help to provide an adequate current path and heat dissipation.
3. Keep the power traces and load connections short and wide. This practice is essential for high efficiency. Use thick copper PCBs (2oz or 1oz vs. 0.5oz) to enhance full-load efficiency and thermal dissipation.
4. Use precision resistors (1% or better) for better accuracy.

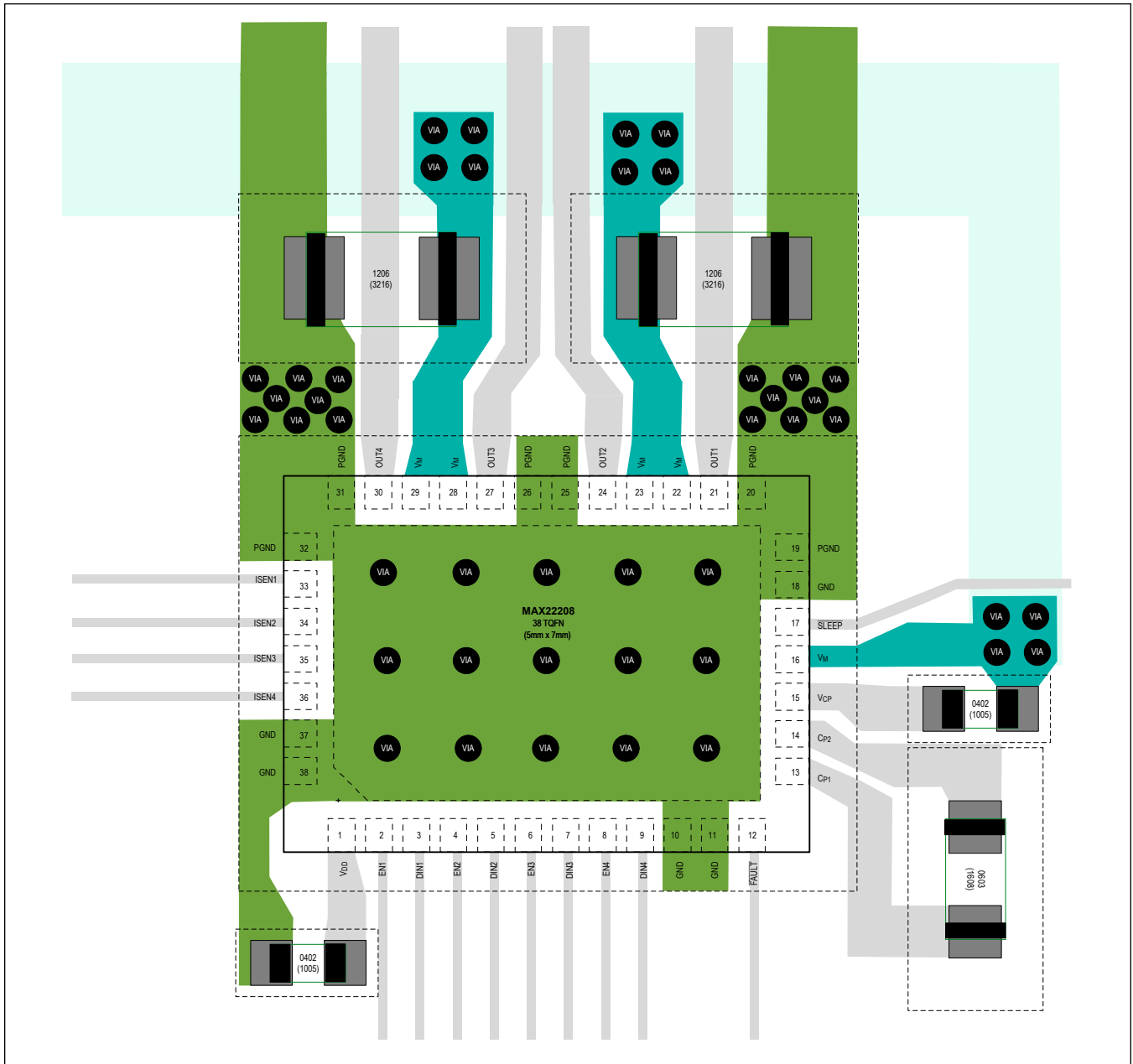
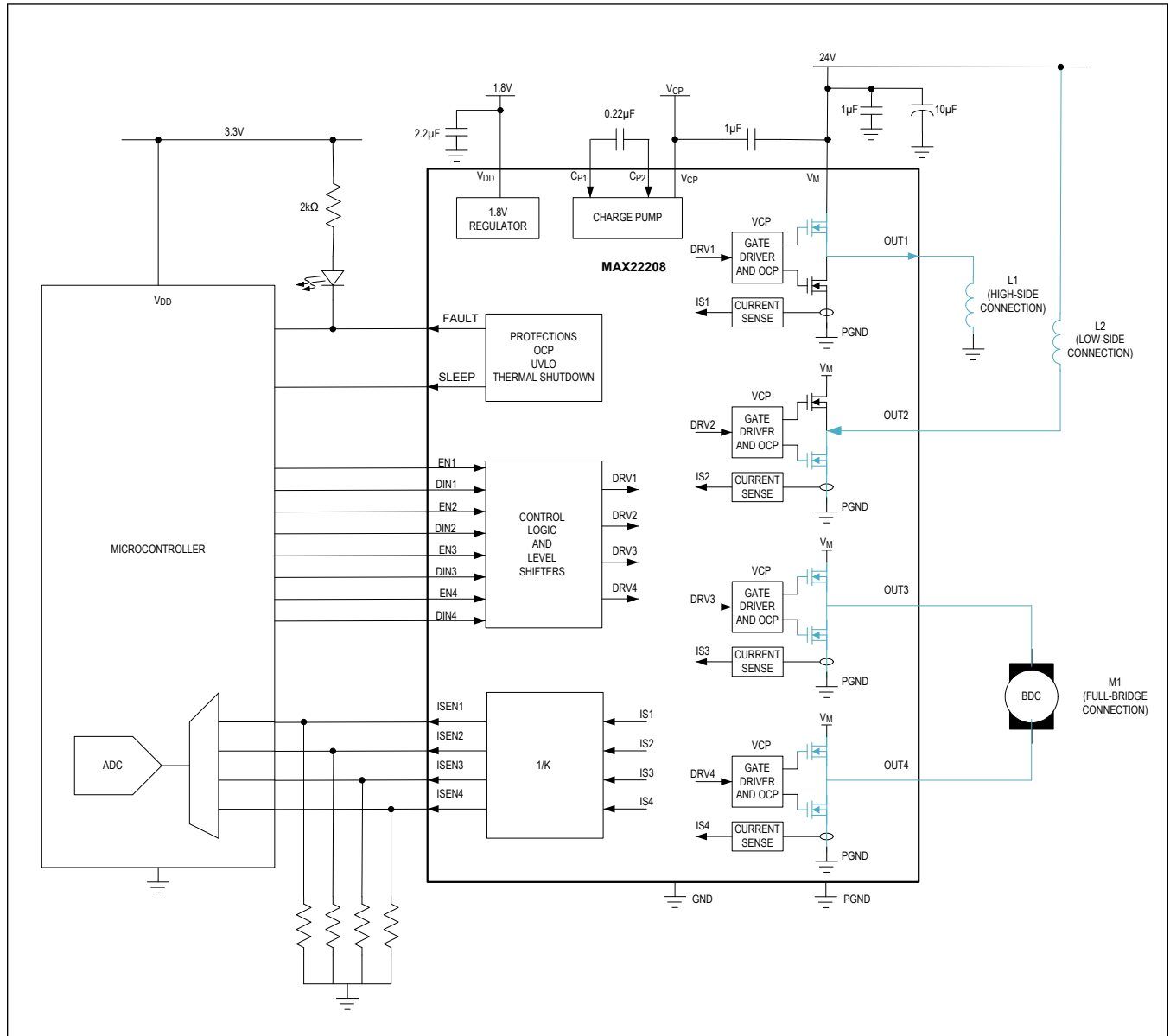

Figure 1. MAX22208 Recommended Layout

Typical Application Circuits

Application Diagram



MAX22208

65V, 3.8A Quad Half H-Bridge Drivers with
Integrated Current Sense

Ordering Information

PART NUMBER	TEMPERATURE RANGE	PIN-PACKAGE
MAX22208ATU+	-40°C to +125°C	38 TQFN-EP*
MAX22208ATU+T	-40°C to +125°C	38 TQFN-EP*
MAX22208AUU+T	-40°C to +125°C	38 TSSOP-EP*

+Denotes a lead(Pb)-free/RoHS-compliant package.

T = Tape and reel.

*EP = Exposed pad.

Revision History

REVISION NUMBER	REVISION DATE	DESCRIPTION	PAGES CHANGED
0	8/23	Initial release	—
1	5/24	Updated <i>Ordering Information</i> to remove future product annotation from MAX22208AUU+T	18