

General Description

The MAX17555C evaluation kit (EV kit) is a fully assembled and tested circuit board that demonstrates the performance of the MAX17555C, a 4V to 60V, 50mA, Ultra-Small, High Efficiency, Synchronous Step-Down DC-DC converter in an 8-pin TDFN (2mm x 2mm) package. The EV kit is designed to operate over a 14V to 60V input and provides a 12V, 30mA output. The EV kit is set up to turn ON at 20V (max) and turn OFF at 14V (max) using EN/UV and HYST pins. The step-down converter works at a 70kHz frequency and delivers a peak efficiency of 89.1% with supplied components.

The EV kit is simple to use and easily configurable with minimal external components. The MAX17555C features a programmable input EN/UV, HYST threshold, and an open-drain **RESET** signal. The device offers built-in hiccup mode protection for overload and short circuit conditions, as well as thermal shutdown. The EV kit is compliant with the CISPR32 class B standard.

Features

- 14V to 60V Input-Voltage Range for the Step-Down Converter
- 12V Output Voltage, Up to 30mA Continuous Load Current
- 89.1% Peak Efficiency
- Minimal Number of External Components
- 70kHz Switching Frequency
- Resistor Programmable Input Enable-Undervoltage (EN/UV) and Hysteresis (HYST)
- Internal Loop Compensation
- 0.8ms (typ) Internal Soft-Start Time
- Open-Drain **RESET** Output to Monitor Output Voltage
- Hiccup-mode Overcurrent and Overtemperature Protection
- Proven PCB Layout
- Fully Assembled and Tested

Ordering Information appears at end of data sheet.

EV Kit Photo

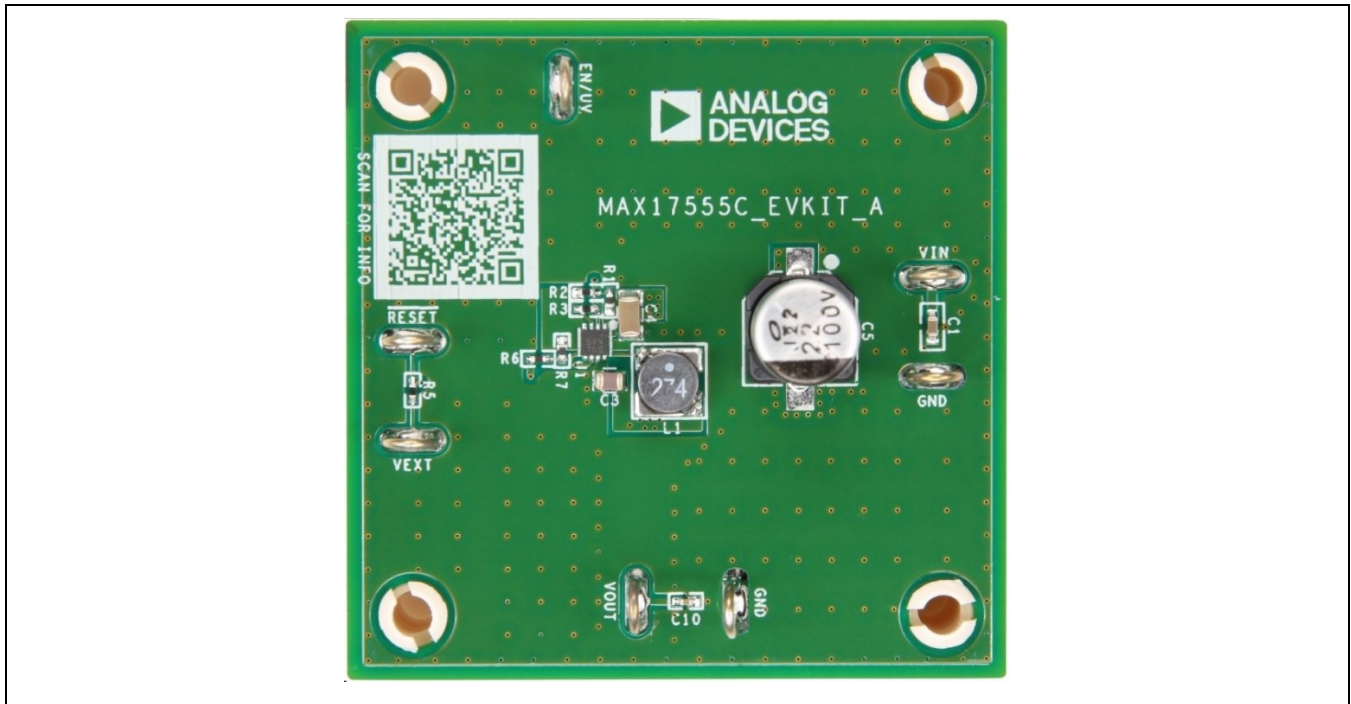

Quick Start

Configuration Diagram

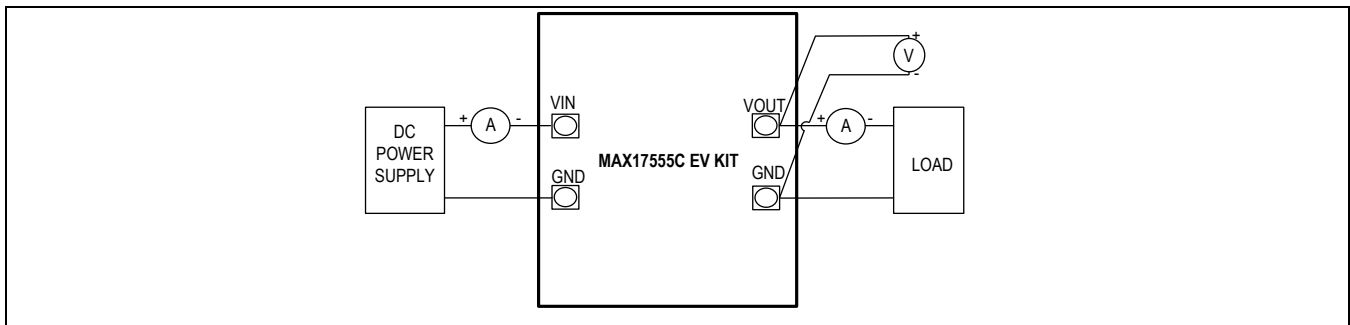

Figure 1. MAX17555C EV Kit Setup Diagram

Required Equipment

- MAX17555CEVKIT#
- One 60V adjustable, 0.5A DC power supply
- One 5V DC, 5mA power supply
- Load resistors capable of sinking up to 30mA at 12V
- Digital multimeters (DMM)

EV Kit Setup and Procedure

A typical bench setup for the MAX17555C EV kits is shown in [Figure 1](#).

The EV kit is fully assembled and tested. Follow the steps to verify and test the operation of individual converters.

Warning:

- Do not turn on the power supply until all connections are completed.
- Do not touch any part of the circuit with bare hands or conductive materials when powered up.
- Make sure all high-voltage capacitors are fully discharged before handling. Allow five minutes after disconnecting the input power source before touching circuit parts.

Equipment Setup and Procedure

1. Set the power supply to a voltage between 20V and 60V. Disable the power supply.
2. Connect the positive terminal of the 60V power supply to the VIN PCB pad and the negative terminal to the nearest GND PCB pad. Connect the positive terminal of the 30mA load to the VOUT PCB pad and the negative terminal to the nearest GND PCB pad.
3. Set the digital multimeter to voltage mode and connect across the VOUT PCB pad and the nearest GND PCB pad.
4. Connect the positive terminal of the 5V power supply to the VEXT PCB pad and the negative terminal to the nearest GND PCB pad.
5. Enable both power supplies.
6. Verify that the output voltmeter displays 12V and, if required, measure the output current using a DMM in ammeter mode.
7. If required, vary the input voltage from 14V to 60V and the load current from 0mA to 30mA, then verify that the output voltage is 12V with respect to GND.

Detailed Description

The MAX17555C EV kit provides a proven design to evaluate the MAX17555C, a 4V to 60V, 50mA ultra-small, high efficiency, synchronous step-down DC-DC converter. The EV kit comes with installed components for delivering 12V, 30mA (max) output current from a 14V to 60V input. The EV kit can be used to verify the EN/UV and HYST features of the MAX17555C. The MAX17555C works at the switching frequency of 70kHz. The EV kit can be programmed to different output voltages with an appropriate output inductor (L1) and an output capacitor (C6). The EV kit can also be used to verify the output overload or short circuit protection as well as the thermal shutdown protection. Refer to the MAX17555C IC data sheet to change the EV kit configuration to a different specification.

Setting the Input EN/UV Level with HYST

The device offers an adjustable input undervoltage and adjustable hysteresis levels. Set the voltage at which the device turns on and turns off with a resistor network connected between IN, EN/UV, HYST, and GND pins (see [Figure 2](#)). Choose R1 to be 3.32MΩ (max), then calculate R2 and R3 as follows:

$$R2 = \frac{V_{ENF} \times R1}{(V_{IN(OFF)} - V_{ENF})}$$

$$R3 = \frac{V_{ENR} \times R1 \times R2}{(V_{IN(ON)} \times R2 - V_{ENR} \times (R1 + R2))}$$

where $V_{IN(ON)}$ and $V_{IN(OFF)}$ are the voltages at which the device is required to turn on and turn off respectively. Refer to the MAX17555 IC data sheet for more information.

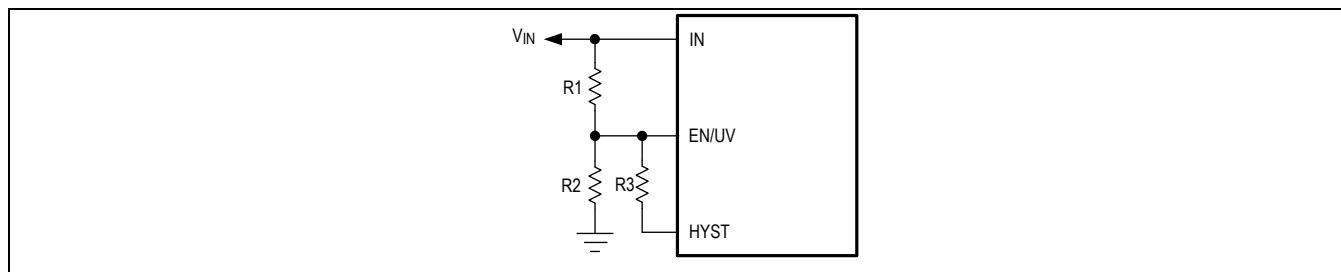

Figure 2. Setting the Input Undervoltage Level with Hysteresis

Adjusting the Output Voltage

The output voltage of MAX17555C can be programmed from 0.8V to $0.9 \times V_{IN}$. Set the output voltage by using a resistive feedback divider from output to GND (see [Figure 3](#)). Connect the center node of the divider to the FB/VO pin. Choose R_B less than or equal to 100kΩ and calculate R_U with the following equation:

$$R_U = R_B \times \left[\frac{V_{OUT}}{0.8} - 1 \right]$$

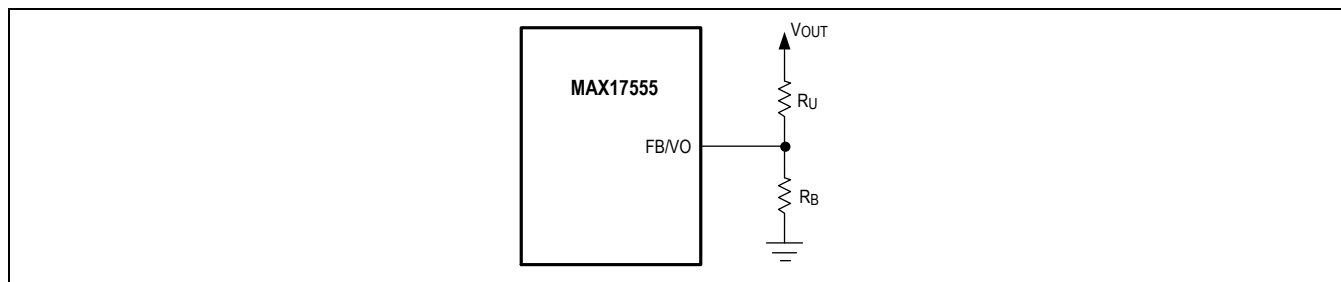

Figure 3. Setting the Output Voltage

RESET Output

The MAX17555C **RESET** pin has a maximum 6V voltage rating. The EV kit provides a VEXT PCB pad for connecting the pullup voltage of the **RESET** pin. The EV kit also provides a **RESET** PCB pad to monitor the stepdown converter output. **RESET** goes to high impedance 30 μ s after the step-down converter outputs rise above 95% of the programmed output voltage. **RESET** goes low when the regulator output voltage drops below 92% (typ) of the programmed output voltage. **RESET** also goes low when EN/UV voltage falls below its threshold value. Refer to the MAX17555 IC data sheet for more information.

Hot Plug-In and Long Input Cables

The MAX17555CEVKIT# PCB layout provides an optional electrolytic capacitor (C5). This capacitor limits the peak voltage at the input of the converter when the DC input source is hot-plugged to the EV kit input terminals with long input cables. The equivalent series resistance (ESR) of the electrolytic capacitor dampens the oscillations caused by interaction between the inductance of the long input cables and the ceramic capacitors at the buck converter input.

Electromagnetic Interference

Compliance to conducted emission (CE) standards requires an electromagnetic interference (EMI) filter at the input of a switching power converter. The EMI filter attenuates high-frequency currents drawn by the switching power converter and limits the noise injected back into the input power source.

The MAX17555CEVKIT# has designated footprints for the placement of conducted EMI filter components as per the bill of materials (BOM). Use of these filter components results in lower conducted EMI below CISPR32 Class B limits. Cut open the trace at L2 before installing conducted EMI filter components. The EV kit layout is also designed to limit radiated emissions from switching nodes of the power converter and complies with CISPR32 Class B RE limits.

MAX17555C EV Kit Typical Operating Characteristics

($V_{IN} = V_{EN} = 24V$, $T_A = +25^\circ C$, unless otherwise noted.)

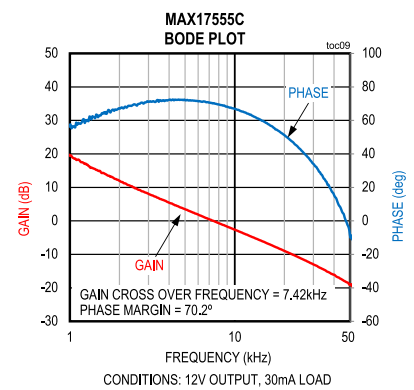
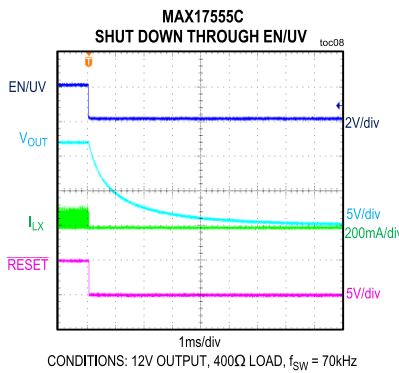
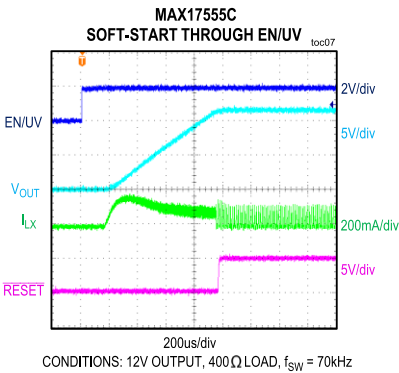
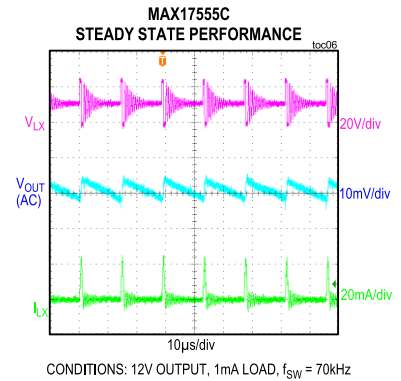
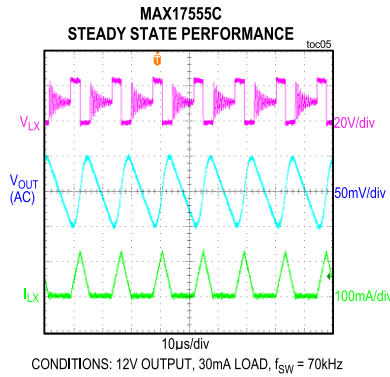
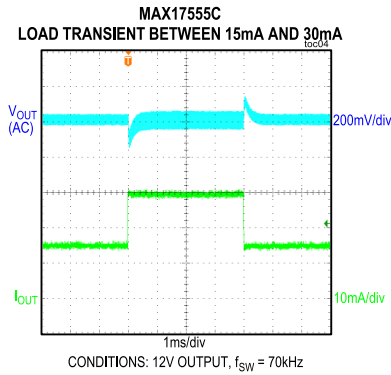
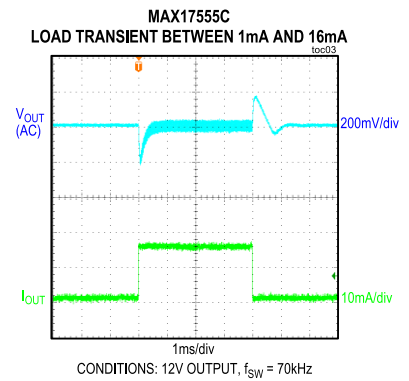
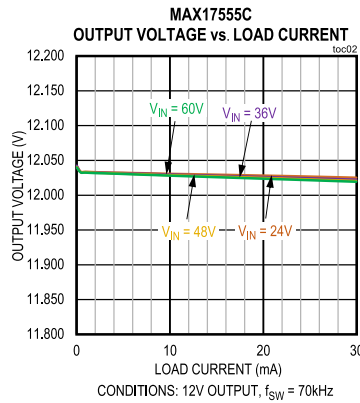
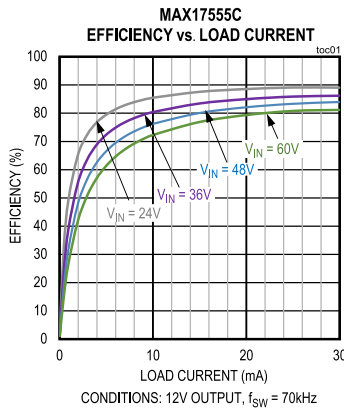

MAX17555C EV Kit Bill of Materials

ITEM	QTY	DESIGNATOR	DESCRIPTION	MANUFACTURER PART NUMBER
1	1	C1	0.1 μ F, 10%, 100V, X7R, Ceramic capacitor (0603)	MURATA GRM188R72A104KA35
2	1	C3	10 μ F, 10%, 25V, X7R, Ceramic capacitor (0805)	MURATA GRM21BZ71E106KE15
3	1	C4	1 μ F, 10%, 100V, X7R, Ceramic capacitor (1206)	TDK C3216X7R2A105K160AA
4	1	C5	22 μ F, 20%, 100V, Electrolytic capacitor	PANASONIC EEE-TG2A220UP
5	1	C10	0.1 μ F, 10%, 16V, X7R, Ceramic capacitor (0402)	MURATA GRM155R71C104KA88
6	1	R1	3.32M Ω , \pm 1%, 1/16W, resistor (0402)	VISHAY CRCW04023M32FK
7	1	R2	287k Ω , \pm 1%, 1/16W, resistor (0402)	VISHAY CRCW0402287KFK
8	1	R3	953k Ω , \pm 1%, 1/16W, resistor (0402)	VISHAY CRCW0402953KFKEDC
9	1	R5	100k Ω , \pm 1%, 1/16W, resistor (0402)	VISHAY CRCW0402100KFK
10	1	R6	698k Ω , \pm 1%, 1/16W, resistor (0402)	PANASONIC ERJ-2RK6983
11	1	R7	49.9k Ω , \pm 1%, 1/16W, resistor (0402)	PANASONIC ERJ-2RK4992
12	1	L1	INDUCTOR, 270 μ H, 0.42A	COILCRAFT MSS5131H-274ME
13	1	U1	4V to 60V, 50mA, Step-Down DC-DC Converter	ANALOG DEVICE MAX17555CATA+
14	0	L2	INDUCTOR, 15 μ H, 0.58A	COILCRAFT LPS3015-153MR
15	0	C2	4.7 μ F, 10%, 100V, X7R, Ceramic capacitor (1206)	MURATA GRM31CZ72A475KE11
16	0	C8	Ceramic capacitor (1206)	NA

MAX17555C EV Kit Schematic

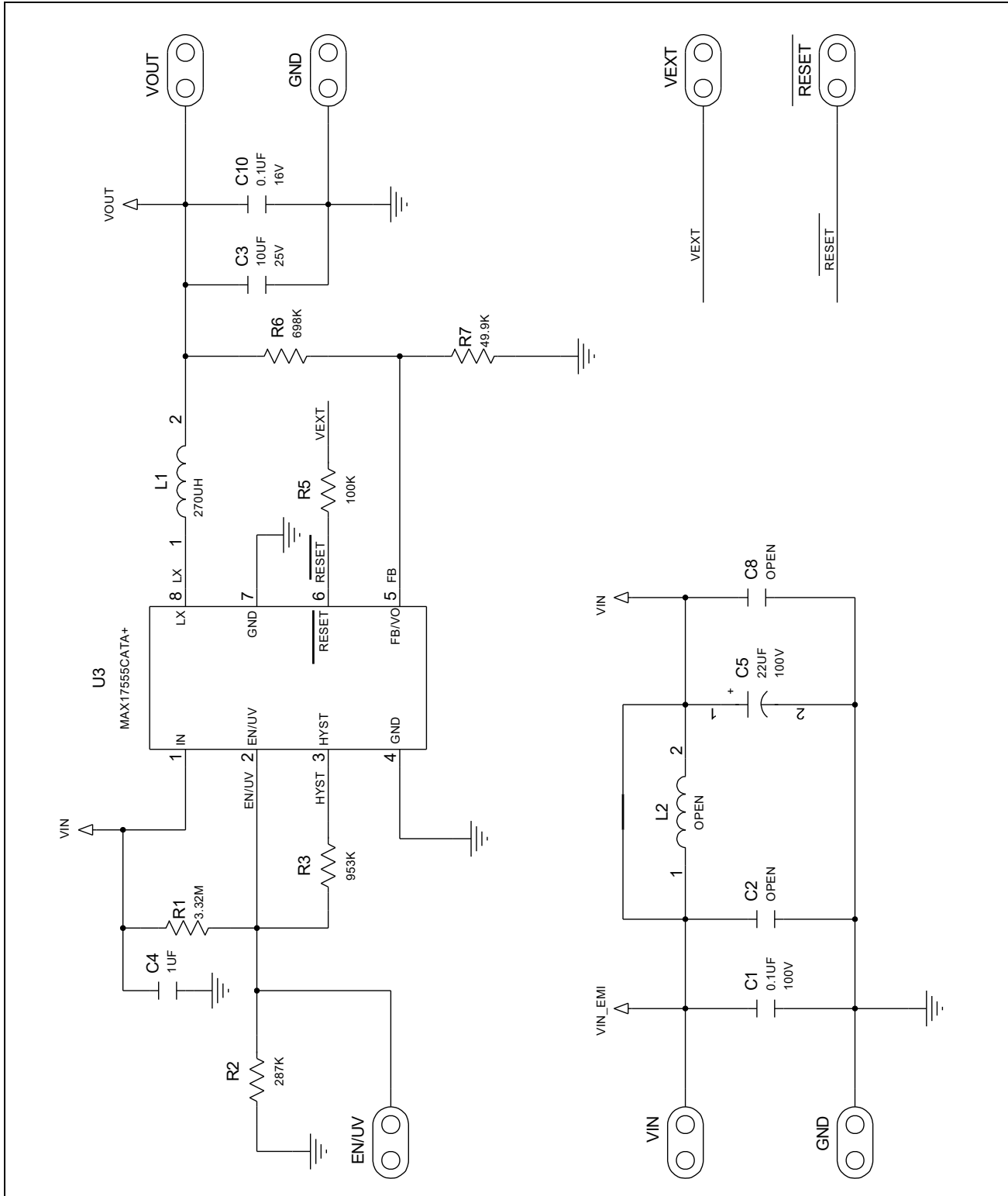

MAX17555C EV Kit PCB Layout

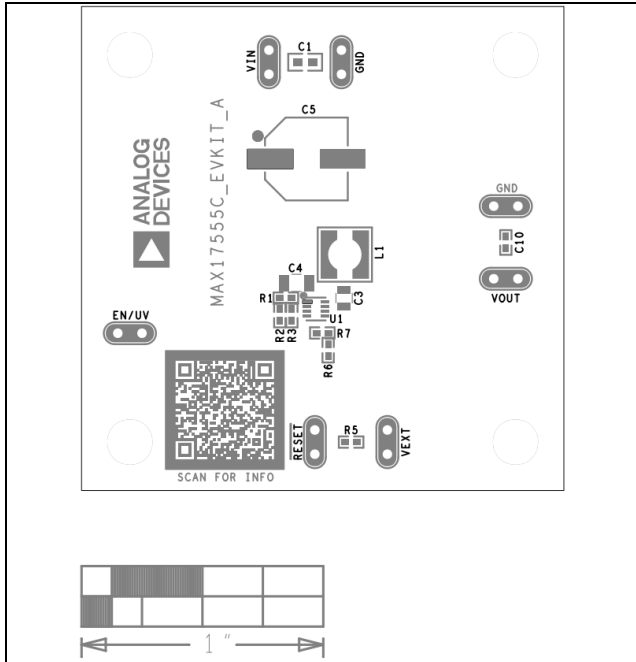

MAX17555C EV Kit PCB Layout—Top Silkscreen

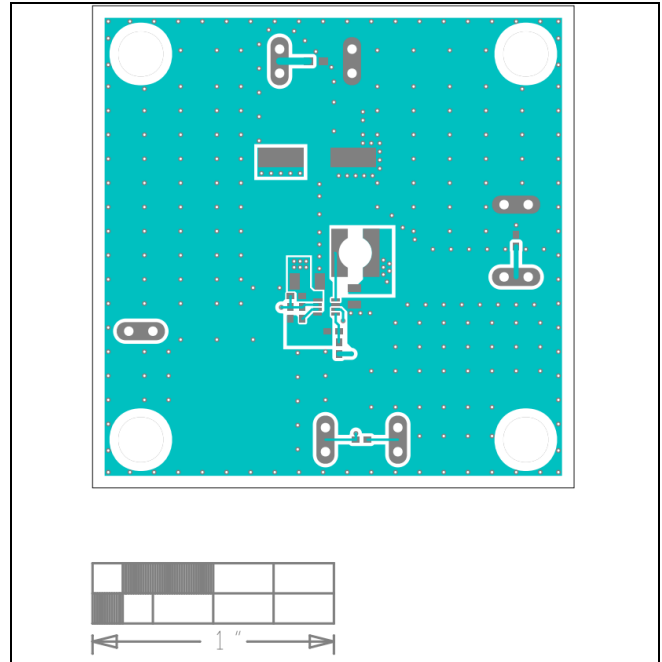

MAX17555C EV Kit PCB Layout—Top Layer

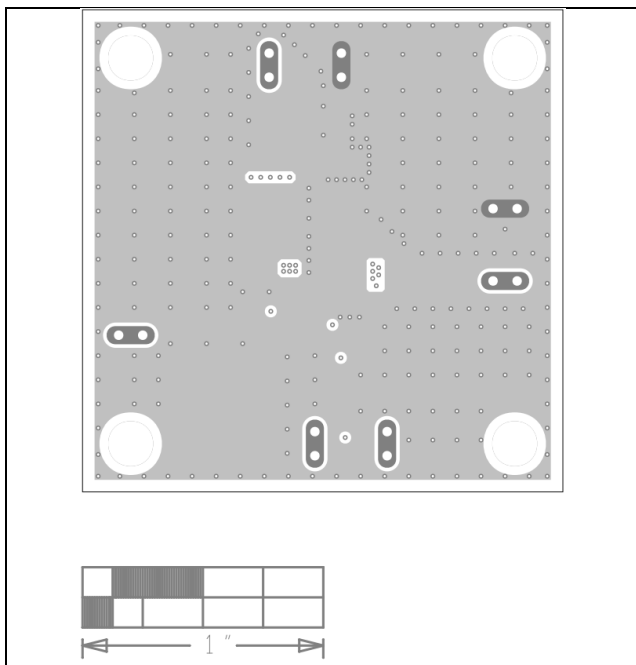

MAX17555C EV Kit PCB Layout—Layer 2

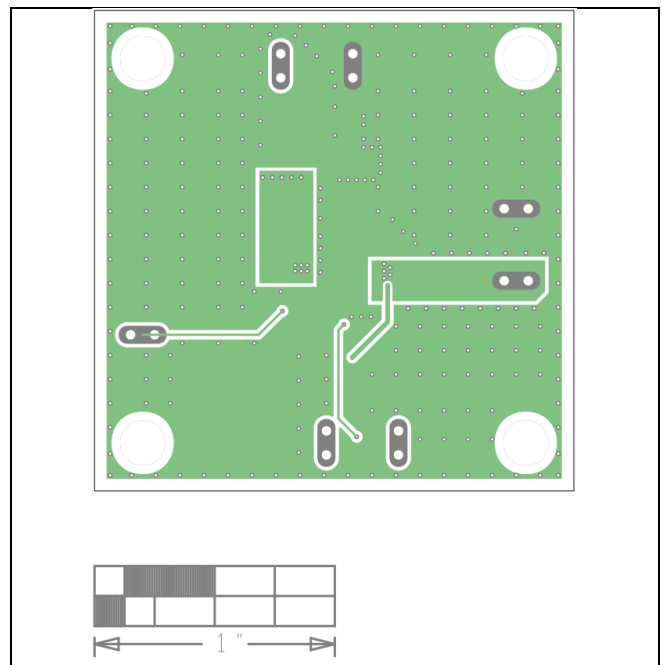

MAX17555C EV Kit PCB Layout—Layer 3

MAX17555C EV Kit PCB Layout (continued)

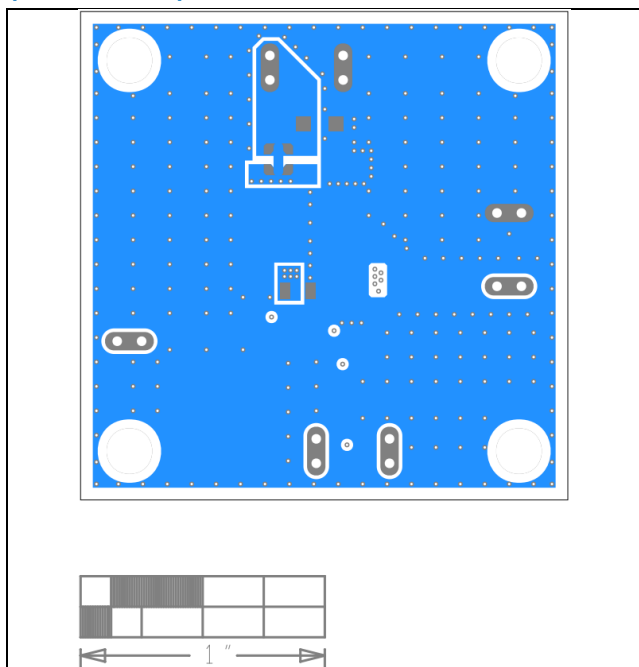

MAX17555C EV Kit PCB Layout—Bottom Layer

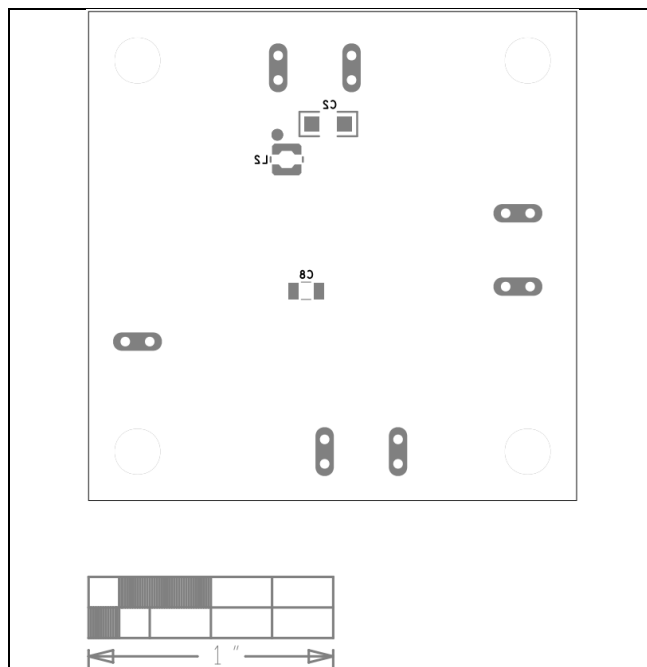

MAX17555C EV Kit PCB Layout—Bottom Silkscreen

Ordering Information

PART NUMBER	TYPE
MAX17555CEVKIT#	EV Kit

#Denotes RoHS compliance.

Component Suppliers

SUPPLIER	WEBSITE
Coilcraft Inc	www.coilcraft.com
Murata Americas	www.murata.com
Vishay Intertechnology	www.vishay.com
Panasonic Corp	www.panasonic.com

Revision History

REVISION NUMBER	REVISION DATE	DESCRIPTION	PAGES CHANGED
0	7/22	Initial release	—

