

Nano Power, Tiny Supervisor with Manual Reset Input

MAX16180–MAX16183

General Description

The MAX16180–MAX16183 are ultra-low-current, single-channel supervisory ICs that monitor the V_{CC} voltage from 1.7V to 4.85V in 50mV increments and assert a reset when the V_{CC} voltage falls below the reset threshold. The reset output remains asserted for the reset timeout period after the V_{CC} voltage rises above the factory-set $V_{CC_TH} + V_{HYS}$. See the [Selector Guide](#) for available reset timeout options.

The MAX16180–MAX16183 include a factory-programmable manual reset input (MR) that can be configured to assert a reset when it receives a rising-edge, falling-edge, active-low, or active-high input signal. The MAX16180/MAX16181 features an open-drain reset output, while the MAX16182/MAX16183 features a push-pull reset output. See the [Selector Guide](#) for reset output configurations.

All devices are specified over the -40°C to $+125^{\circ}\text{C}$ temperature range. The MAX16180–MAX16183 are available in a tiny $0.97\text{mm} \times 0.97\text{mm} \times 0.5\text{mm}$, 4-bump WLP (0.35mm pitch).

Applications

- Chargers
- Portable/Battery-Powered Equipment
- e-Readers/Tablets
- Wearable/Portable Accessories
- Smart Phones

Benefits and Features

- 240nA Quiescent Current, Extends Battery Life
- Edge/Level Trigger MR Input
- Factory-Set Reset Timeout Period
- MR Debounce Circuitry
- Factory-Set Threshold: 1.7V to 4.85V
- WLP Package
- -40°C to $+125^{\circ}\text{C}$ Temperature Range

[Ordering Information](#) appears at end of data sheet.

Typical Application Diagram

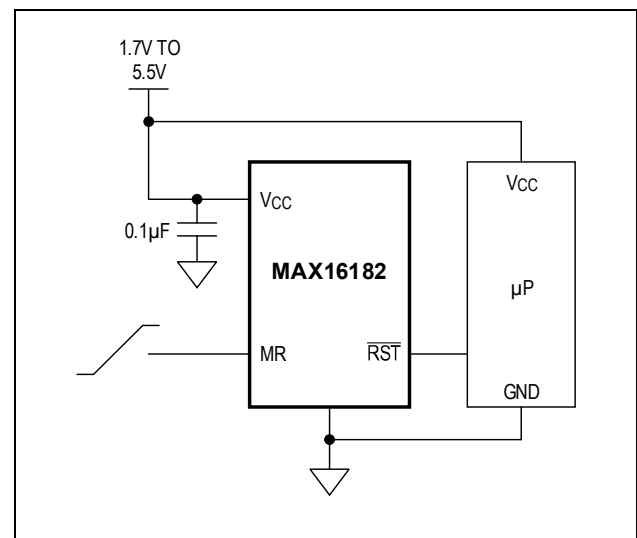

Absolute Maximum Ratings

V _{CC} to GND	-0.3V to +6V	Operating Temperature Range	-40°C to +125°C
MR, $\overline{\text{RST}}$ to GND	-0.3V to +6V	Junction Temperature	+150°C
Continuous Sink/Source Current (All Pins)	-20mA to +20mA	Soldering Temperature (reflow).....	+300°C
Continuous Power Dissipation (Multilayer Board) WLP (T _A = +70°C, derate 9.58mW/C above +70°C.....	766.4mW	Storage Temperature Range	-65°C to +150°C

Stresses beyond those listed under "Absolute Maximum Ratings" may cause permanent damage to the device. These are stress ratings only, and functional operation of the device at these or any other conditions beyond those indicated in the operational sections of the specifications is not implied. Exposure to absolute maximum rating conditions for extended periods may affect device reliability.

Package Information

WLP

Package Code	N40G0+1
Outline Number	21-100638
Land Pattern Number	Application Note 1891
Thermal Resistance, Four Layer Board:	
Junction-to-Ambient (θ_{JA})	104.41°C/W
Junction-to-Case Thermal Resistance (θ_{JC})	N/A

For the latest package outline information and land patterns (footprints), go to www.maximintegrated.com/packages. Note that a "+", "#", or "-" in the package code indicates RoHS status only. Package drawings may show a different suffix character, but the drawing pertains to the package regardless of RoHS status.

Package thermal resistances were obtained using the method described in JEDEC specification JESD51-7, using a four-layer board. For detailed information on package thermal considerations, refer to www.maximintegrated.com/thermal-tutorial.

Electrical Characteristics

($V_{CC} = 1.7V$ to $5.5V$, $T_A = T_J = -40^{\circ}C$ to $125^{\circ}C$, unless otherwise noted. Typical Values are at $T_A = +25^{\circ}C$.)

PARAMETER	SYMBOL	CONDITIONS	MIN	TYP	MAX	UNITS
INPUT VOLTAGE						
Input Voltage Range	V_{CC}	Operating range	1.7		5.5	V
		Reset output is guaranteed to be at known state	1.5			
Supply Current	I_{CC}	$T_A = -40^{\circ}C$ to $+85^{\circ}C$, reset not asserted, $V_{CC} = V_{TH} + 10\%$		240	600	nA
V_{CC} Threshold Accuracy	V_{TH}	V_{CC} falling	-1.0		+1.0	%
V_{CC} Threshold Resolution		Threshold range = 1.7V to 4.85V		50		mV
V_{CC} Threshold Hysteresis	V_{TH_HYS}	$V_{CC} =$ rising, $1.7V \leq V_{CC} \leq 4.85V$		38		mV
V_{CC} to Reset Output Delay	t_D	Measured with 2.5% threshold overdrive		184		μs
Reset Timeout Period Accuracy	t_{RP}	Measured from point where V_{CC} is above V_{TH} (Note 1)	-25		+25	%
RESET OUTPUT VOLTAGE						
Reset Output Voltage Low (Note 2)	V_{OL}	$V_{CC} = 4.25V$, $I_{SINK} = 10mA$			0.4	V
		$V_{CC} = 2.5V$, $I_{SINK} = 3.2mA$			0.4	
		$V_{CC} = 1.7V$, $I_{SINK} = 1mA$			0.4	
Reset Output Voltage High	V_{OH}	$V_{CC} = 4.50V$, $I_{SOURCE} = 800\mu A$	$0.8 \times V_{CC}$			V
MANUAL RESET INPUT						
Manual Reset Debounce Period	MR_{DB}	MR input configured as level trigger	$t_{RP} = 0.01s - 2s$	20		ms
			$t_{RP} = 0.31ms$	0.6		
MR to Reset Delay	t_{DELAY}	MR configured as edge triggered input		1.1		μs
MR Input Voltage Low	V_{IL}				$0.3 \times V_{CC}$	V
MR Input Voltage High	V_{IH}		$0.7 \times V_{CC}$			V
MR Internal Pullup Resistor		MR configured as active-low input		50		k Ω
MR Internal Pulldown Resistor		MR configured as active-high input		50		k Ω

Note 1: The reset timeout period is affected by the V_{CC} rise time during power-up. For a V_{CC} rise time of $10\mu s$ or faster, the additional t_{RP} is about $8.5ms$ (typ).

Note 2: The Reset Output Voltage Low spec applies to open-drain and push-pull versions

Typical Operating Characteristics

($V_{CC} = 5V$, $T_A = 25^\circ C$, unless otherwise noted)

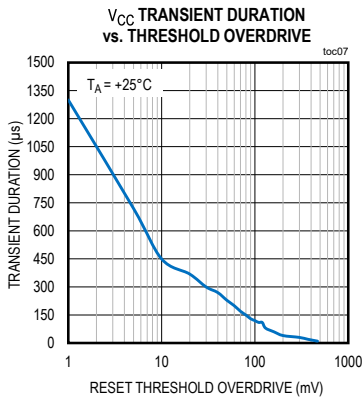
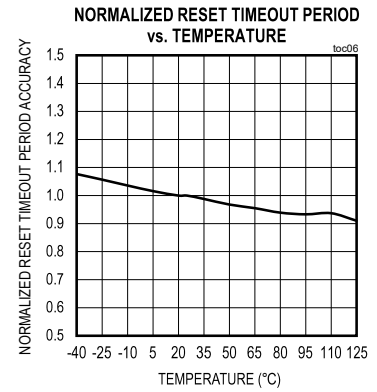
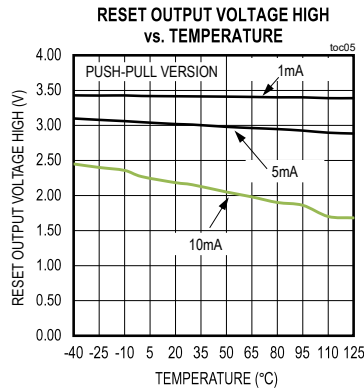
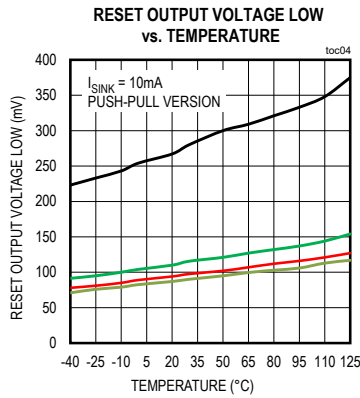
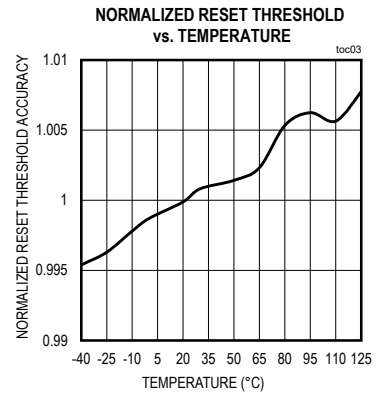
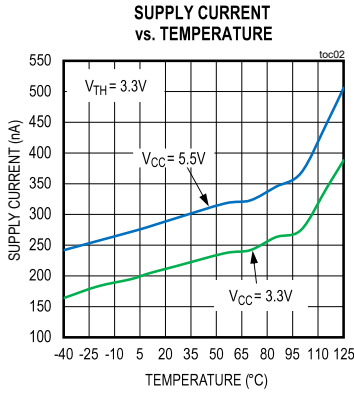
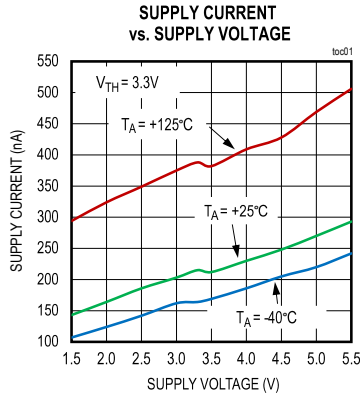

Pin Configuration

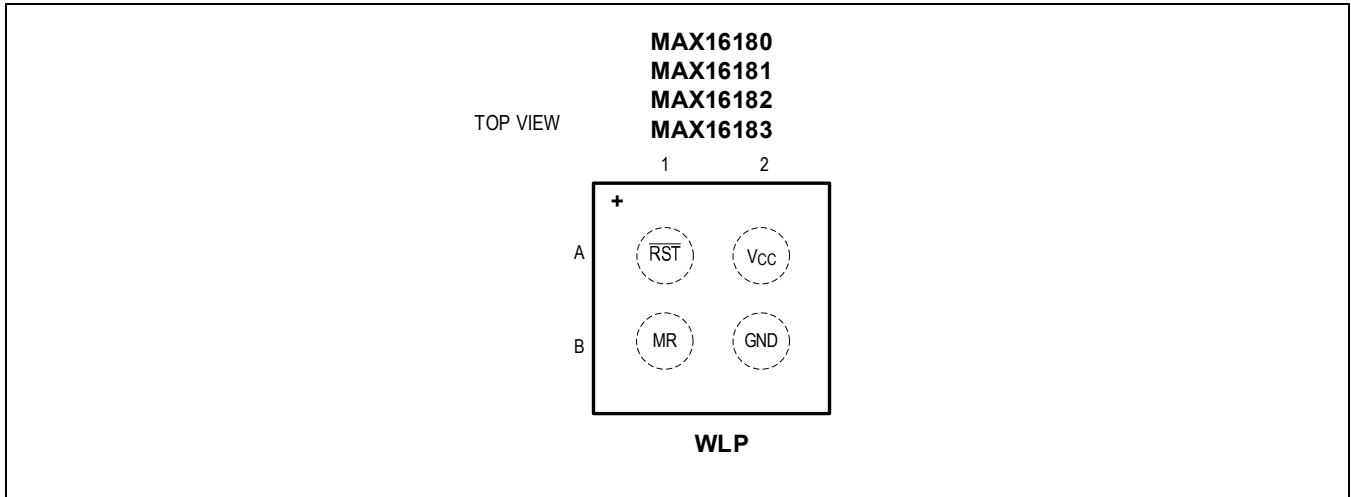

Pin Descriptions

PIN	NAME	FUNCTION
A1	\overline{RST}	Reset Output. Reset asserts when V_{CC} drops below factory set threshold or when MR receives either an edge-triggered or level-triggered signal. For the open-drain versions, connect a pullup resistor for active-low option and a pulldown resistor for active-high option.
A2	V_{CC}	Positive Supply Input Voltage. Connect V_{CC} to the positive side of the input voltage. Bypass V_{CC} with a 0.1 μ F ceramic capacitor to GND.
B1	MR	Manual Reset Input. See Manual Reset Input for more details.
B2	GND	Ground

Functional Diagram

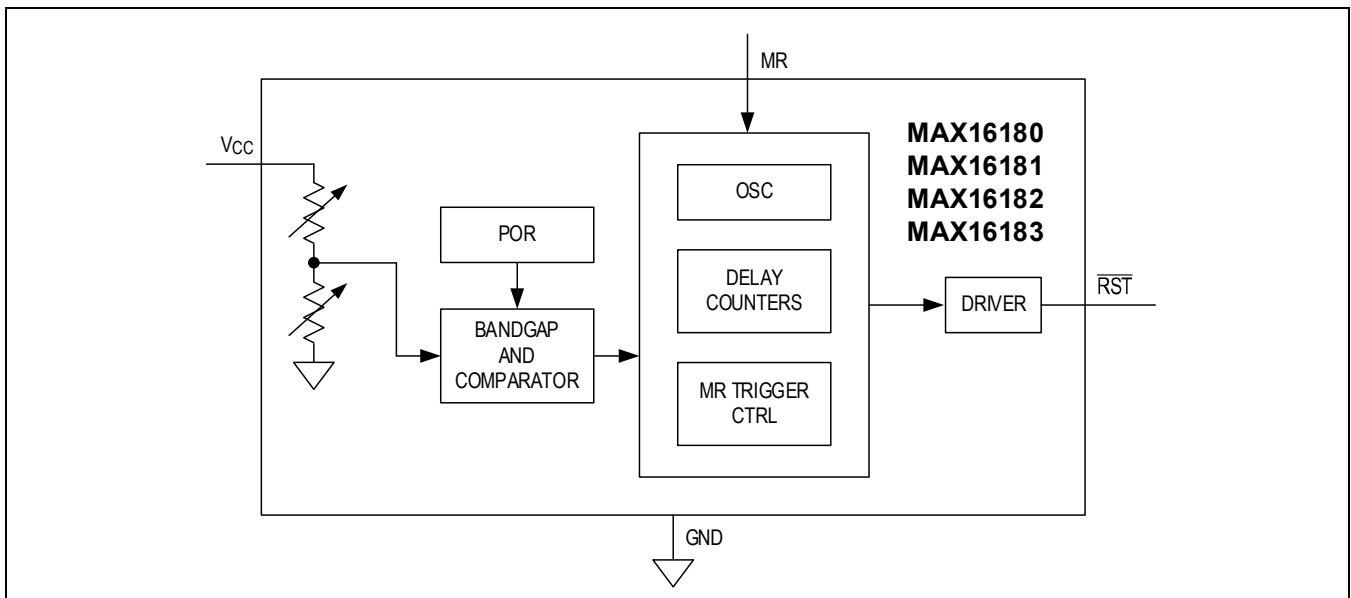

Detailed Description

The MAX16180–MAX16183 are 240nA supervisor ICs that monitor the V_{CC} voltage from 1.7V to 4.85V in 50mV increments. The manual reset input is factory-programmable to assert the reset output using an edge-trigger or level-trigger input. During normal operation, when the V_{CC} voltage falls below the factory-set threshold, the reset output asserts and remains asserted for the reset timeout period after the V_{CC} voltage rises above the threshold voltage. The MAX16180/MAX16181 feature an open-drain reset output, while the MAX16182/MAX16183 features a push-pull reset output. See [Q](#) for more details.

Manual Reset Input

Many μ P-based products require manual reset capability, allowing the operator, a test technician, or external logic circuit to initiate a reset. The MAX16180–MAX16183 feature four factory-programmable manual reset input configurations. See [Q](#) for available options.

For the edge-triggered manual reset input configuration, the MAX16180–MAX16183 assert the reset output on either the falling or rising of the MR input (see the [Selector Guide](#) table for MR configurations. Any subsequent transition on MR is ignored until after the expiration of the reset timeout period. See [Figure 1](#) and [Figure 2](#) for more detail.

For the level-trigger manual reset input configuration, the MAX16180–MAX16183 assert the reset output after MR stays in an active state longer than the debounce period (t_{DB}). The reset output deasserts after the reset timeout period when MR becomes inactive. See [Figure 3](#) and [Figure 4](#) for more details.

Manual Reset Input Configurations

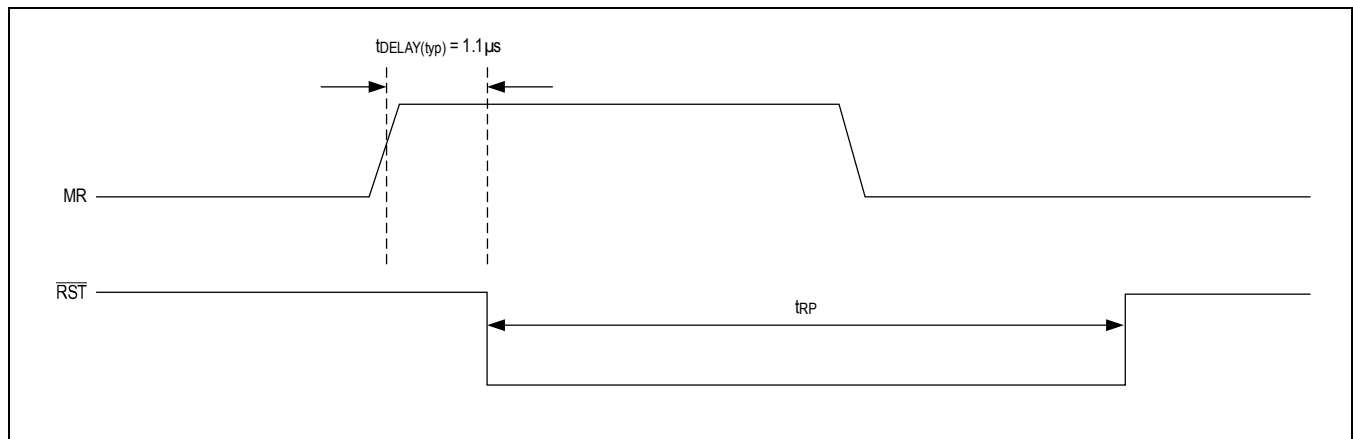

Figure 1. Falling-Edge Trigger Manual Reset Input

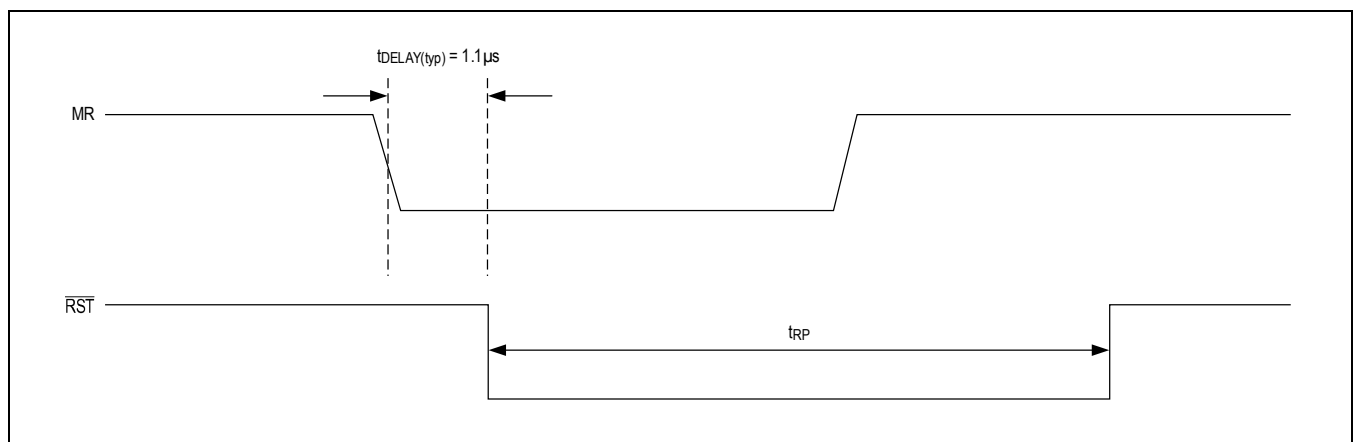

Figure 2. Rising-Edge Trigger Manual Reset Input

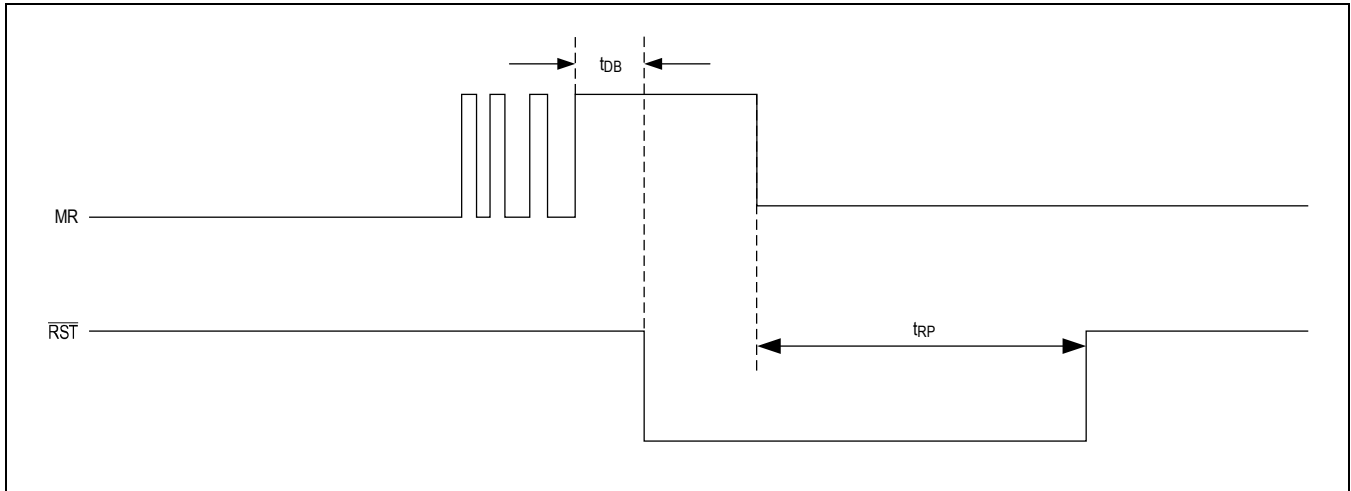

Figure 3. Active-High Trigger Manual Reset Input

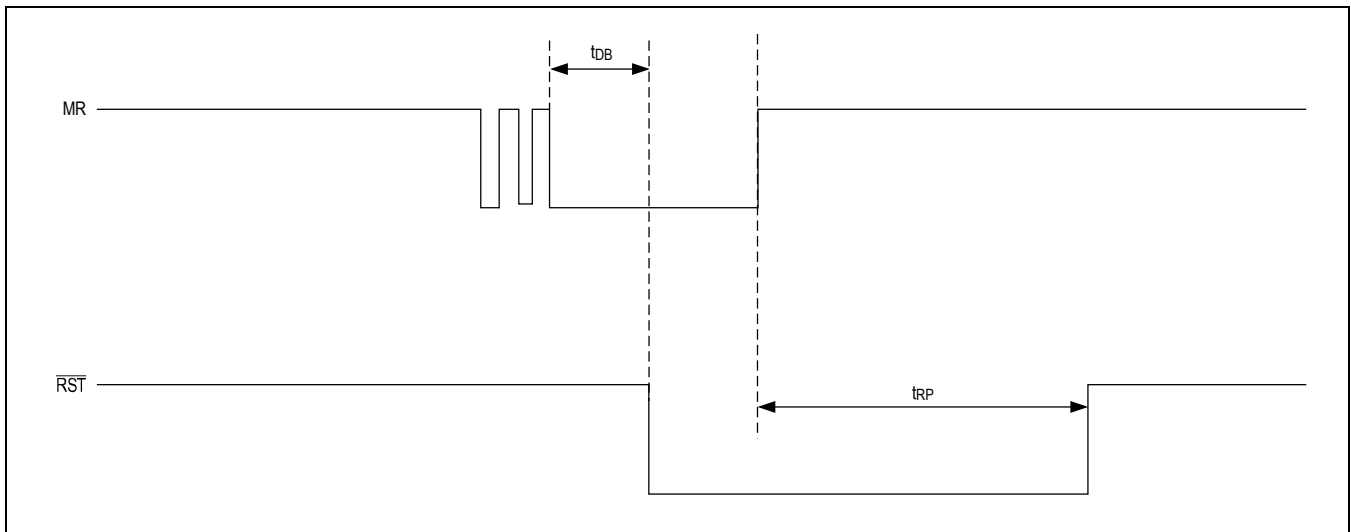

Figure 4. Active-Low Trigger Manual Reset Input

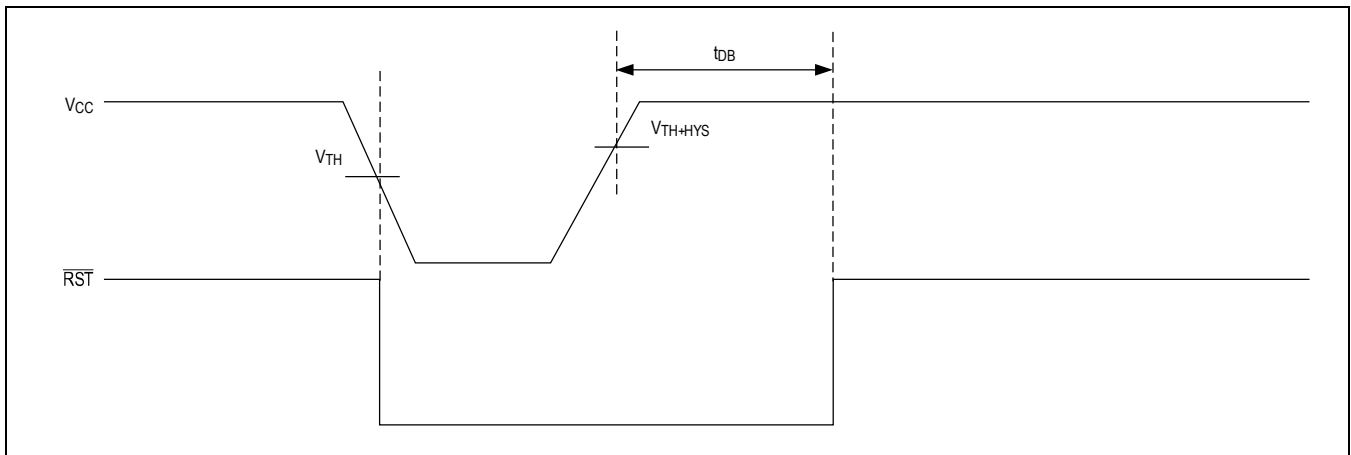

Figure 5. Reset Response to V_{CC} Rising-Edge Above Threshold Voltage + Hysteresis

V_{CC} Threshold Input

The MAX16180–MAX16183 monitor V_{CC} from 1.7V to 4.85V in approximately 50mV increments. The reset output asserts when V_{CC} falls below V_{TH}. See [0](#) for threshold options.

The reset output stays asserted for the reset timeout period when V_{CC} rises above V_{TH} + V_{HYST}. See the timing diagram in [Figure 5](#).

Reset Output

The MAX16180–MAX16183 μ P supervisor circuits assert a reset to prevent code execution errors during power-up, power-down, and brownout conditions. For active-low reset output configuration, the reset output is guaranteed to be valid for V_{CC} down to 1.1V. For active-high reset output configuration, the reset output is guaranteed to be valid for V_{CC} down 1.5V.

The MAX16180–MAX16183 offer eight factory-programmable reset timeout period options from 0.31ms to 2s. See [0](#) for available options.

Applications Information

Power Supply Bypassing and Grounding

The MAX16180–MAX16183 operates from a 1.70V to 5.5V supply. An undervoltage lockout ensures that the outputs are in the correct states when the UVLO is exceeded. Bypass V_{CC} to ground with a 0.1 μ F capacitor as close to the device as possible. The additional capacitor improves transient immunity. For fast-rising V_{CC} transients, additional capacitance may be required.

Configuration Tables

Factory-Set Reset Output Configuration Options

PART NUMBER	RESET OUTPUT CONFIGURATION
MAX16180	Open-Drain, Active-Low
MAX16181	Open-Drain, Active-High
MAX16182	Push-Pull, Active-Low
MAX16183	Push-Pull, Active-High

Contact factory for available options.

Factory-Set Manual Trigger Input Options

SUFFIX	MR TRIGGER INPUT
I	Falling Edge
J	Rising Edge
K	Active-Low
L	Active-High

Contact factory for available options.

V_{CC} Threshold Options

SUFFIX	V _{TH,CC} (V)	SUFFIX	V _{TH,CC} (V)
170	1.70	330	3.30
175	1.75	335	3.35
180	1.80	340	3.40
185	1.85	345	3.45
190	1.90	350	3.50
195	1.95	355	3.55
200	2.00	360	3.60
205	2.05	365	3.65

SUFFIX	V _{TH,CC} (V)	SUFFIX	V _{TH,CC} (V)
210	2.10	370	3.70
215	2.15	375	3.75
220	2.20	380	3.80
225	2.25	385	3.85
230	2.30	390	3.90
235	2.35	395	3.95
240	2.40	400	4.00
245	2.45	405	4.05
250	2.50	410	4.10
255	2.55	415	4.15
260	2.60	420	4.20
265	2.65	425	4.25
270	2.70	430	4.30
275	2.75	435	4.35
280	2.80	440	4.40
285	2.85	445	4.45
290	2.90	450	4.50
295	2.95	455	4.55
300	3.00	460	4.60
305	3.05	465	4.65
310	3.10	470	4.70
315	3.15	475	4.75
320	3.20	480	4.80
325	3.25	485	4.85

Reset Timeout Period Options

SUFFIX	RESET TIMEOUT PERIOD			UNITS
	T _A = +25°C	T _A = -40°C TO +125°C		
	TYP	MIN	MAX	
A	0.31	0.24	0.38	ms
B	10	7.5	12.5	ms
C	50	35.5	62.5	ms
D	100	75	125	ms
E	250	187.5	312.5	ms
F	500	475	625	ms
G	1000	750	1250	ms
H	2000	1500	2500	ms

Contact factory for available options.

Selector Guide

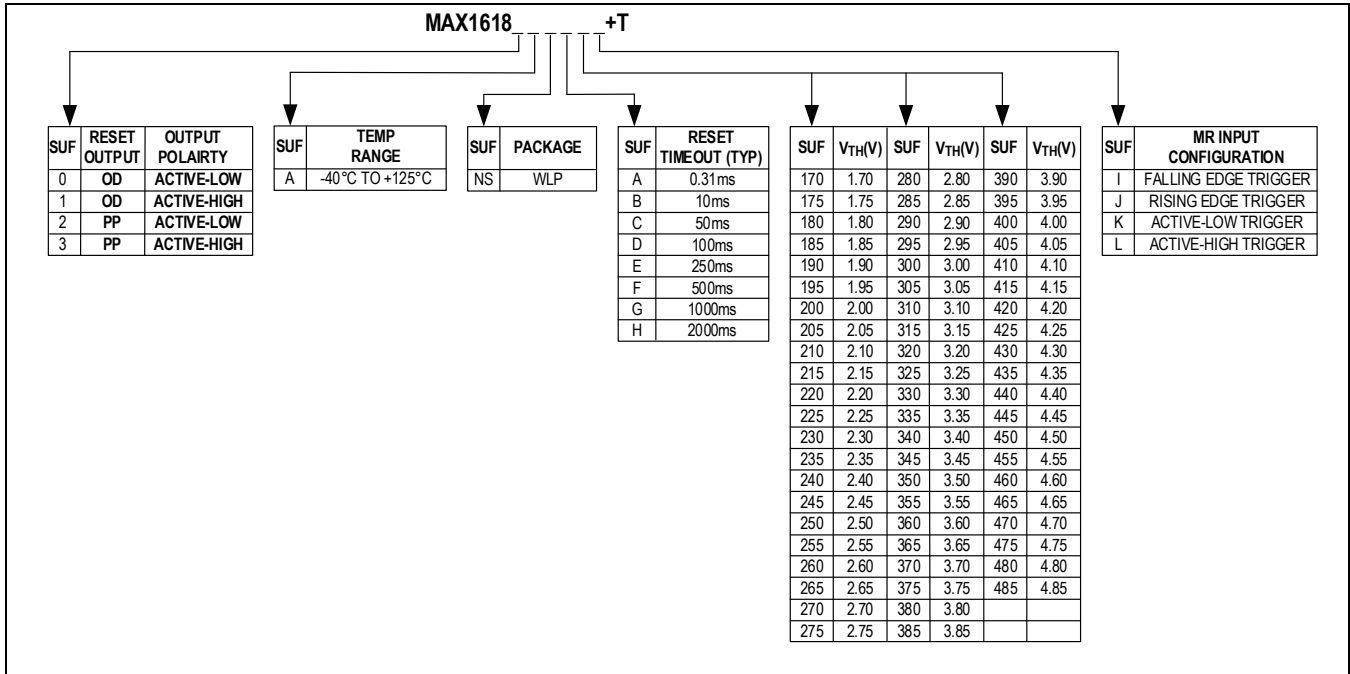

Typical Application Circuit

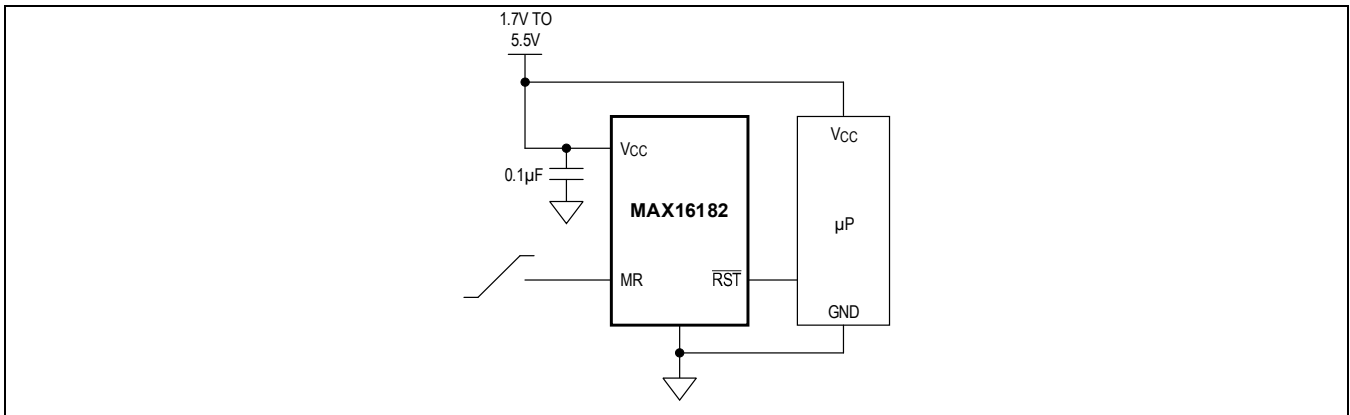

Ordering Information

PART NUMBER	TEMP RANGE	PIN-PACKAGE
MAX16182ANSE330K+T	-40°C to +125°C	4-BUMP WLP
MAX1618 _____ +T*	-40°C to +125°C	4-BUMP WLP

Note: See the [Selector Guide](#) for reset output, reset timeout period, and threshold voltage options.

For additional options and future products, visit www.maximintegrated.com.

+ Denotes a lead (Pb)-free/RoHS-compliant package.

T = Tape and reel.

* Future Product—contact factory for availability.

Revision History

REVISION NUMBER	REVISION DATE	DESCRIPTION	PAGES CHANGED
0	11/22	Release for Market intro	—

