

36V Low Cost High Side Current Sense in a SOT-23

FEATURES

- Gain Configurable with Two Resistors
- Low Offset Voltage: 250 μ V Maximum
- Full Scale Output Current: 1mA
- Supply Range: 2.7V to 36V, 44V Absolute Maximum
- Low Input Bias Current: 40nA Maximum
- PSRR: 106dB Minimum
- Low Supply Current: 65 μ A Typical, $V^+ = 12$ V
- Operating Temperature Range: -40° C to 125° C
- Low Profile (1mm) ThinSOT™ Package
- AEC-Q100 Qualified for Automotive Applications

APPLICATIONS

- Current Shunt Measurement
- Battery Monitoring
- Power Management
- Motor Control
- Lamp Monitoring
- Overcurrent and Fault Detection

DESCRIPTION

The LT[®]6106 is a versatile high side current sense amplifier. Design flexibility is provided by the excellent device characteristics: 250 μ V maximum offset and 40nA maximum input bias current. Gain for each device is set by two resistors and allows for accuracy better than 1%.

The LT6106 monitors current via the voltage across an external sense resistor (shunt resistor). Internal circuitry converts input voltage to output current, allowing for a small sense signal on a high common mode voltage to be translated into a ground referenced signal. The low DC offset allows for monitoring very small sense voltages. As a result, a small valued shunt resistor can be used, which minimizes the power loss in the shunt.

The wide 2.7V to 44V input voltage range, high accuracy and wide operating temperature range make the LT6106 ideal for automotive, industrial and power management applications. The very low power supply current of the LT6106 also makes it suitable for low power and battery operated applications.

All registered trademarks and trademarks are the property of their respective owners.

TYPICAL APPLICATION

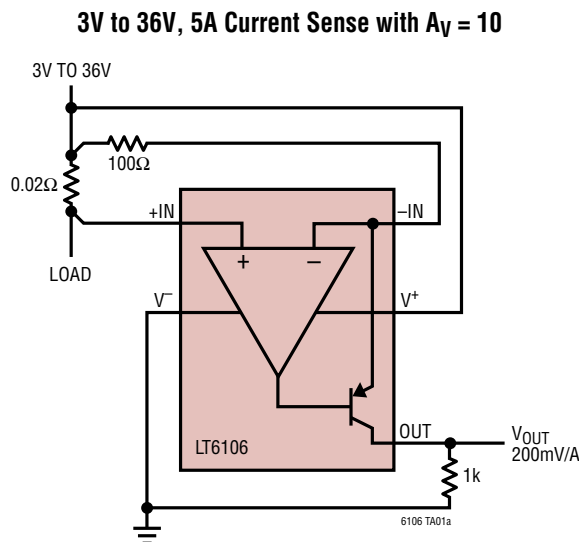

Measurement Accuracy vs Load Current

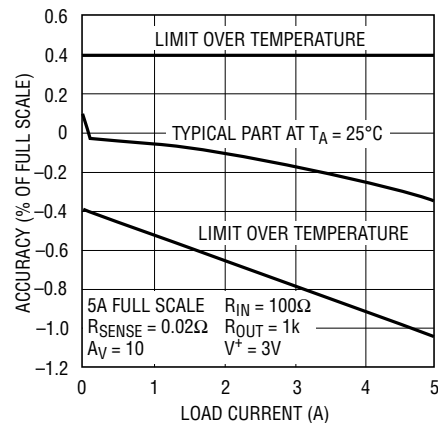

ELECTRICAL CHARACTERISTICS The ● denotes the specifications which apply over the full specified operating temperature range, otherwise specifications are at $T_A = 25^\circ\text{C}$. $V^+ = 12\text{V}$, $V^+ = V_{\text{SENSE}^+}$, $R_{\text{IN}} = 100\Omega$, $R_{\text{OUT}} = 10\text{k}$, Gain = 100 unless otherwise noted.

SYMBOL	PARAMETER	CONDITIONS	MIN	TYP	MAX	UNITS
$V_{\text{OUT(HIGH)}}$	Output Swing High (Referred to V^+)	$V_{\text{SENSE}} = 120\text{mV}$	●		1.2	V
					1.4	V
	Minimum Output Voltage (Note 5)	$V_{\text{SENSE}} = 0\text{mV}$, $R_{\text{IN}} = 100\Omega$, $R_{\text{OUT}} = 10\text{k}$	●	12	45	mV
					65	mV
		$V_{\text{SENSE}} = 0\text{mV}$, $R_{\text{IN}} = 500\Omega$, $R_{\text{OUT}} = 10\text{k}$, $V^+ = 12\text{V}$, 36V	●	7	16	mV
					22	mV
BW	Signal Bandwidth (-3dB)	$I_{\text{OUT}} = 1\text{mA}$, $R_{\text{IN}} = 100\Omega$, $R_{\text{OUT}} = 5\text{k}$		200		kHz
t_r	Input Step Response (to 50% of Output Step)	$\Delta V_{\text{SENSE}} = 100\text{mV}$ Step, $R_{\text{IN}} = 100\Omega$, $R_{\text{OUT}} = 5\text{k}$, Rising Edge		3.5		μs
I_S	Supply Current	$V^+ = 2.7\text{V}$, $I_{\text{OUT}} = 0\mu\text{A}$, ($V_{\text{SENSE}} = -5\text{mV}$)	●	60	85	μA
					115	
		$V^+ = 12\text{V}$, $I_{\text{OUT}} = 0\mu\text{A}$, ($V_{\text{SENSE}} = -5\text{mV}$)	●	65	95	μA
					120	
		$V^+ = 36\text{V}$, $I_{\text{OUT}} = 0\mu\text{A}$, ($V_{\text{SENSE}} = -5\text{mV}$)	●	70	100	μA
					130	

Note 1: Stresses beyond those listed under Absolute Maximum Ratings may cause permanent damage to the device. Exposure to any Absolute Maximum Rating condition for extended periods may affect device reliability and lifetime. In addition to the Absolute Maximum Ratings, the output current of the LT6106 must be limited to insure that the power dissipation in the LT6106 does not allow the die temperature to exceed 150°C . See the Applications Information section "Power Dissipation Considerations" for further information.

Note 2: Guaranteed by the gain error test.

Note 3: Gain error refers to the contribution of the LT6106 internal circuitry and does not include errors in the external gain setting resistors.

Note 4: The LT6106C is guaranteed functional over the operating temperature range of -40°C to 85°C . The LT6106C is designed,

characterized and expected to meet specified performance from -40°C to 85°C but is not tested or QA sampled at these temperatures. The LT6106I is guaranteed to meet specified performance from -40°C to 85°C . The LT6106H is guaranteed to meet specified performance from -40°C to 125°C .

Note 5: The LT6106 output is an open collector current source. The minimum output voltage scales directly with the ratio $R_{\text{OUT}}/10\text{k}$.

Note 6: V_{SENSE^+} is the voltage at the high side of the sense resistor, R_{SENSE} . See Figure 1.

Note 7: $V_{\text{SENSE (MAX)}}$ is the maximum sense voltage for which the Electrical Characteristics will apply. Higher voltages can affect performance but will not damage the part provided that the output current of the LT6106 does not exceed the allowable power dissipation as described in Note 1.

TYPICAL PERFORMANCE CHARACTERISTICS

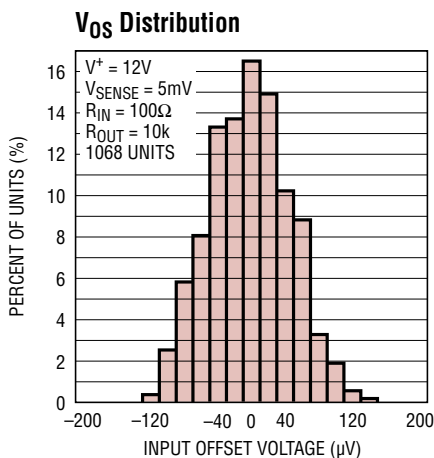

6106 G23

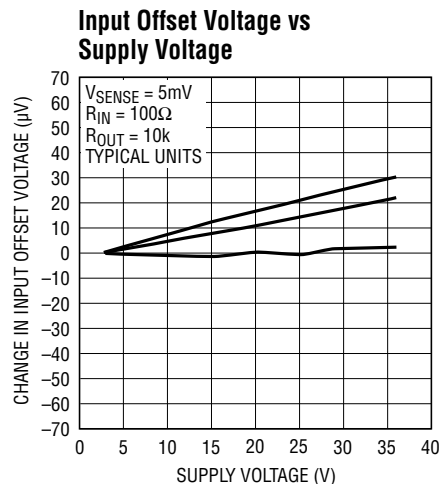

6106 G02

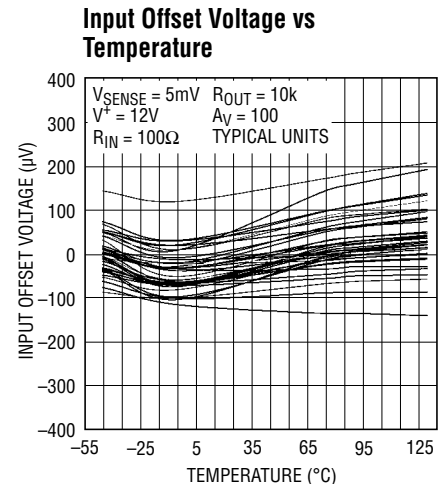

6106 G03

TYPICAL PERFORMANCE CHARACTERISTICS

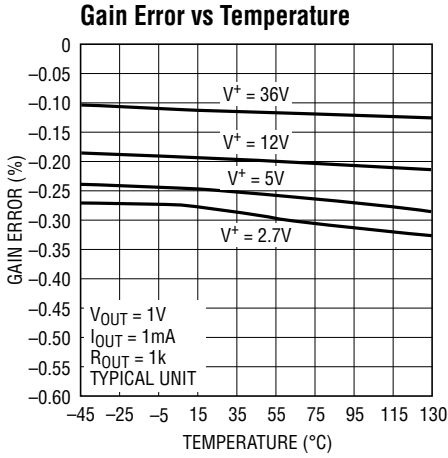

6106 G04

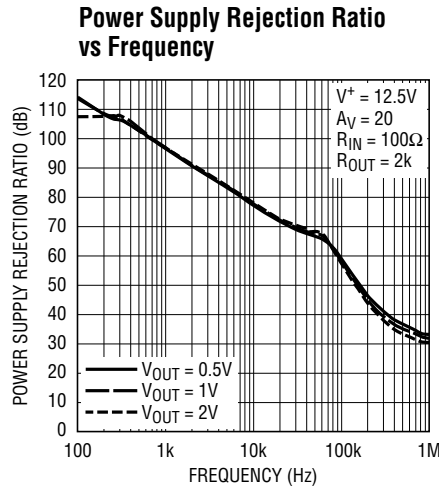

6106 G08

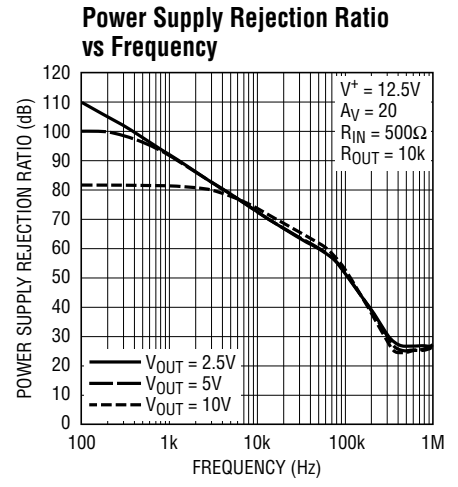

6106 G06

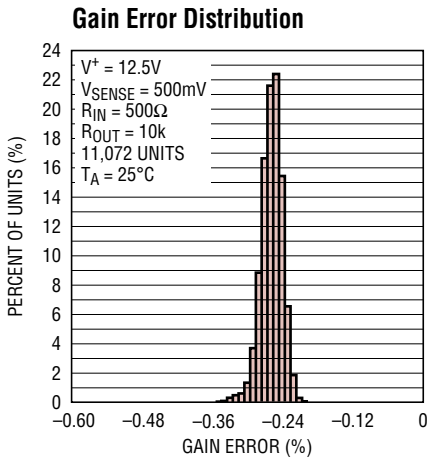

6106 G24

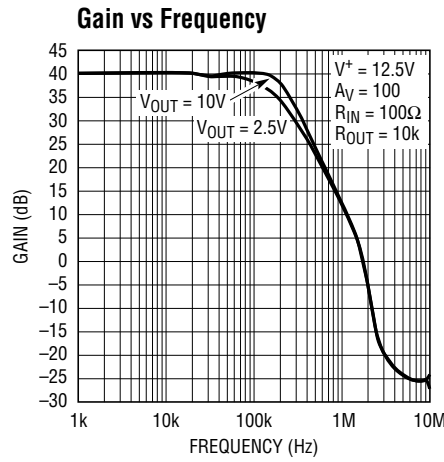

6106 G09

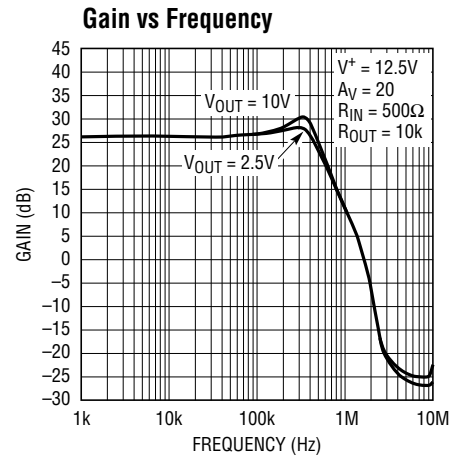

6106 G14

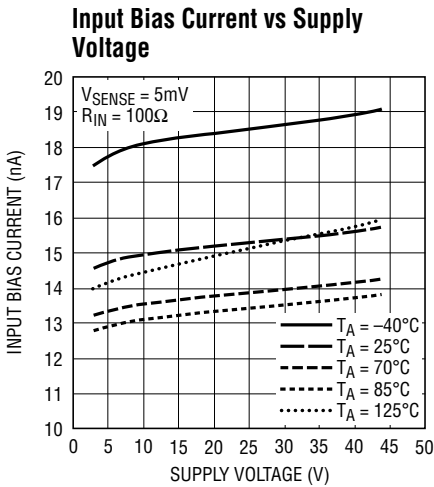

6106 G05

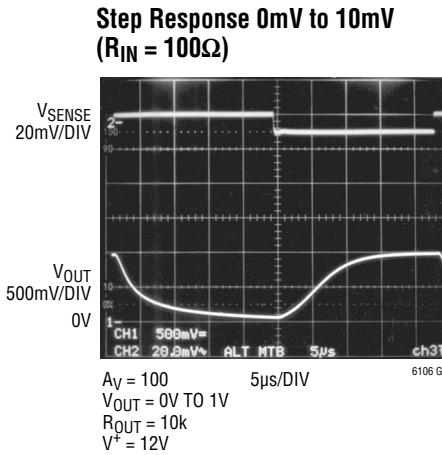

6106 G11

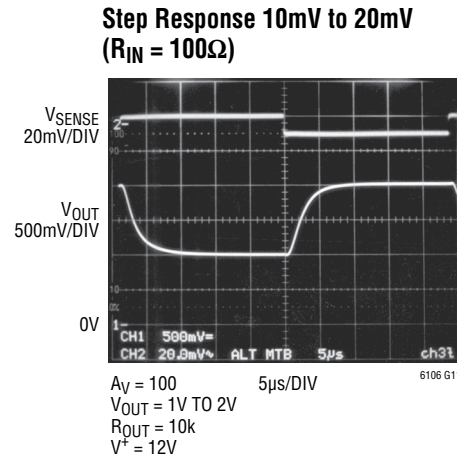

6106 G1

TYPICAL PERFORMANCE CHARACTERISTICS

Step Response 0mV to 100mV
($R_{IN} = 100\Omega$)

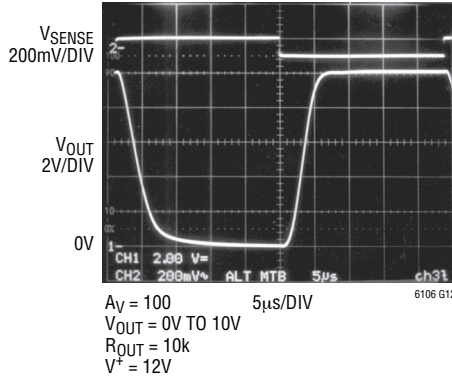

Step Response 10mV to 100mV
($R_{IN} = 100\Omega$)

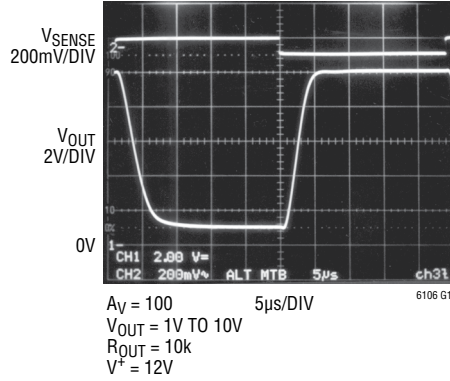

Step Response 50mV to 100mV
($R_{IN} = 500\Omega$)

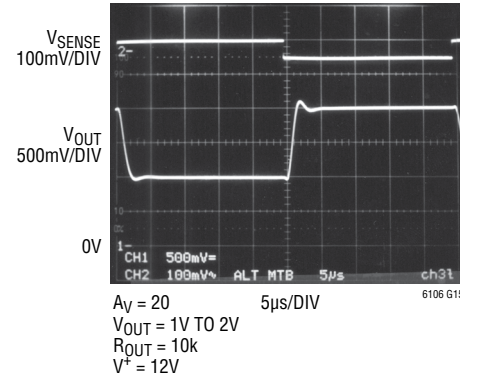

Step Response 0mV to 50mV
($R_{IN} = 500\Omega$)

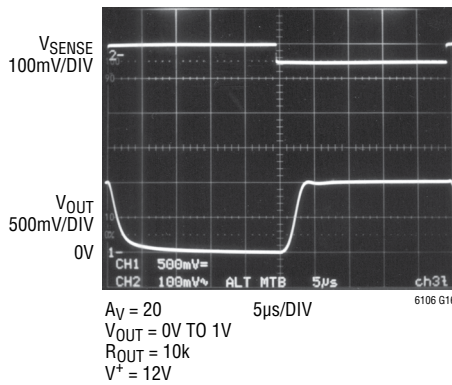

Step Response 50mV to 500mV
($R_{IN} = 500\Omega$)

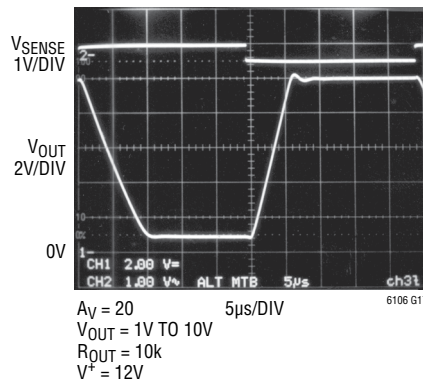

Step Response 0mV to 500mV
($R_{IN} = 500\Omega$)

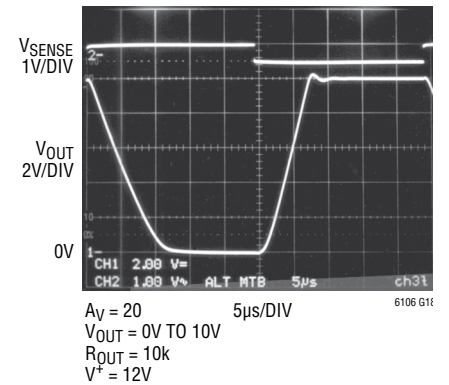

Output Voltage Swing vs Temperature

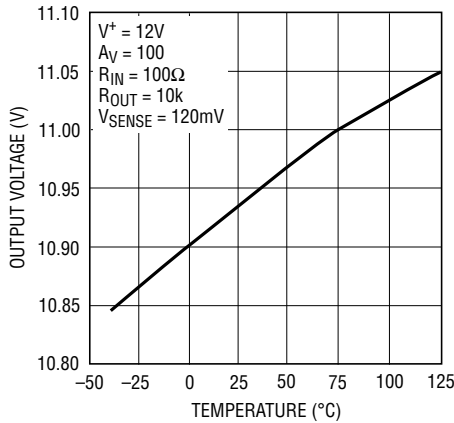

6106 G07

Output Voltage vs Input Sense Voltage ($0mV \leq V_{SENSE} \leq 10mV$)

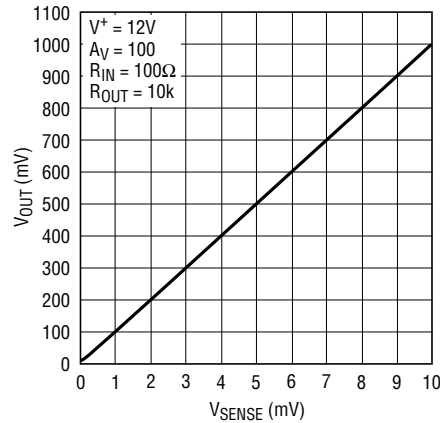

6106 G19

Output Voltage vs Input Sense Voltage ($0mV \leq V_{SENSE} \leq 10mV$)

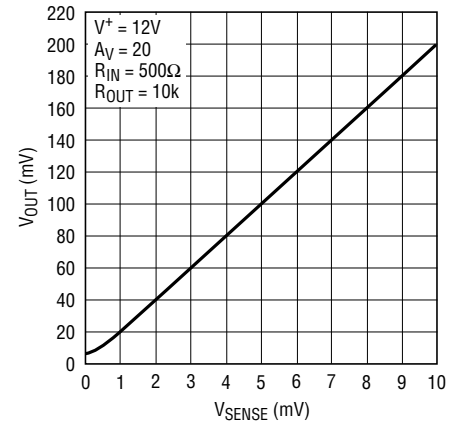

6106 G20

TYPICAL PERFORMANCE CHARACTERISTICS

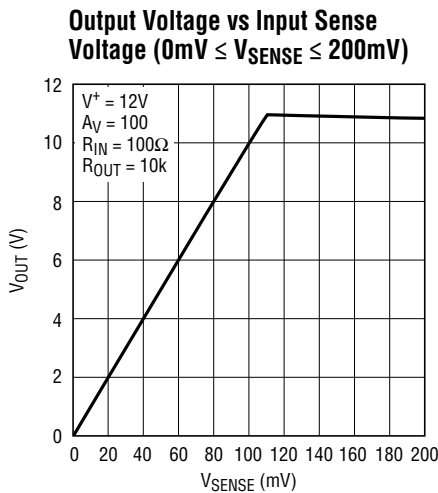

6106 G21

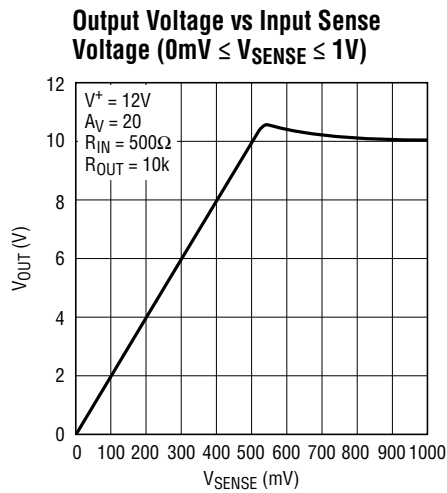

6106 G22

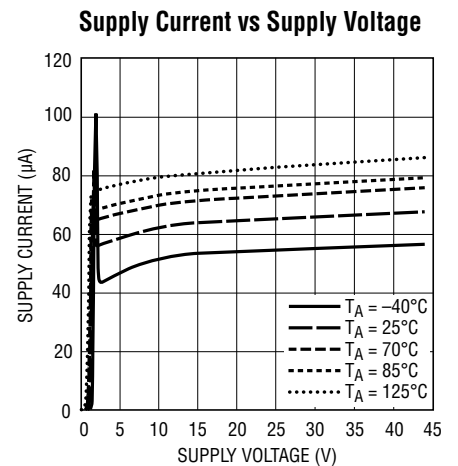

6106 G01

PIN FUNCTIONS

OUT (Pin 1): Current Output. OUT will source a current that is proportional to the sense voltage into an external resistor.

V⁻ (Pin 2): Normally Connected to Ground.

-IN (Pin 3): The internal sense amplifier will drive -IN to the same potential as +IN. A resistor (R_{IN}) tied from V^+ to -IN sets the output current $I_{\text{OUT}} = V_{\text{SENSE}}/R_{\text{IN}}$. V_{SENSE} is the voltage developed across R_{SENSE} .

+IN (Pin 4): Must be tied to the system load end of the sense resistor, either directly or through a resistor.

V⁺ (Pin 5): Positive Supply Pin. The V^+ pin should be connected directly to either side of the sense resistor, R_{SENSE} . Supply current is drawn through this pin. The circuit may be configured so that the LT6106 supply current is or is not monitored along with the system load current. To monitor only the system load current, connect V^+ to the more positive side of the sense resistor. To monitor the total current, including that of the LT6106, connect V^+ to the more negative side of the sense resistor.

BLOCK DIAGRAM

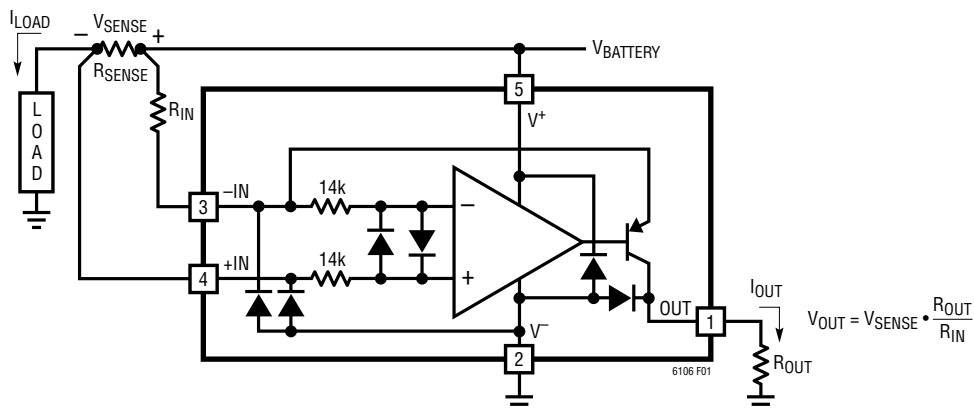

Figure 1. LT6106 Block Diagram and Typical Connection

APPLICATIONS INFORMATION

Introduction

The LT6106 high side current sense amplifier (Figure 1) provides accurate monitoring of current through a user-selected sense resistor. The sense voltage is amplified by a user-selected gain and level shifted from the positive power supply to a ground-referred output. The output signal is analog and may be used as is, or processed with an output filter.

Theory of Operation

An internal sense amplifier loop forces $-IN$ to have the same potential as $+IN$. Connecting an external resistor, R_{IN} , between $-IN$ and V^+ forces a potential across R_{IN} that is the same as the sense voltage across R_{SENSE} . A corresponding current, V_{SENSE}/R_{IN} , will flow through R_{IN} . The high impedance inputs of the sense amplifier will not conduct this current, so it will flow through an internal PNP to the output pin as I_{OUT} .

The output current can be transformed into a voltage by adding a resistor from OUT to V^- . The output voltage is then $V_O = V^- + I_{OUT} \cdot R_{OUT}$.

Table 1. Useful Gain Configurations

GAIN	R_{IN}	R_{OUT}	V_{SENSE} at $V_{OUT} = 5V$	I_{OUT} at $V_{OUT} = 5V$
20	499 Ω	10k	250mV	500 μA
50	200 Ω	10k	100mV	500 μA
100	100 Ω	10k	50mV	500 μA
GAIN	R_{IN}	R_{OUT}	V_{SENSE} at $V_{OUT} = 2.5V$	I_{OUT} at $V_{OUT} = 2.5V$
20	249 Ω	5k	125mV	500 μA
50	100 Ω	5k	50mV	500 μA
100	50 Ω	5k	25mV	500 μA

Selection of External Current Sense Resistor

The external sense resistor, R_{SENSE} , has a significant effect on the function of a current sensing system and must be chosen with care.

First, the power dissipation in the resistor should be considered. The system load current will cause both heat and voltage loss in R_{SENSE} . As a result, the sense resistor should be as small as possible while still providing the input dynamic range required by the measurement. Note that input dynamic range is the difference between the maximum input signal and the minimum accurately measured signal, and is limited primarily by input DC offset of the internal amplifier of the LT6106. In addition, R_{SENSE}

must be small enough that V_{SENSE} does not exceed the maximum input voltage specified by the LT6106, even under peak load conditions. As an example, an application may require that the maximum sense voltage be 100mV. If this application is expected to draw 2A at peak load, R_{SENSE} should be no more than 50m Ω .

Once the maximum R_{SENSE} value is determined, the minimum sense resistor value will be set by the resolution or dynamic range required. The minimum signal that can be accurately represented by this sense amplifier is limited by the input offset. As an example, the LT6106 has a typical input offset of 150 μV . If the minimum current is 20mA, a sense resistor of 7.5m Ω will set V_{SENSE} to 150 μV . This is the same value as the input offset. A larger sense resistor will reduce the error due to offset by increasing the sense voltage for a given load current. Choosing a 50m Ω R_{SENSE} will maximize the dynamic range and provide a system that has 100mV across the sense resistor at peak load (2A), while input offset causes an error equivalent to only 3mA of load current. Peak dissipation is 200mW. If a 5m Ω sense resistor is employed, then the effective current error is 30mA, while the peak sense voltage is reduced to 10mV at 2A, dissipating only 20mW.

The low offset and corresponding large dynamic range of the LT6106 make it more flexible than other solutions in this respect. The 150 μV typical offset gives 60dB of dynamic range for a sense voltage that is limited to 150mV maximum, and over 70dB of dynamic range if the rated input maximum of 0.5V is allowed.

Sense Resistor Connection

Kelvin connection of the $-IN$ and $+IN$ inputs to the sense resistor should be used in all but the lowest power applications. Solder connections and PC board interconnections that carry high current can cause significant error in measurement due to their relatively large resistances. One 10mm \times 10mm square trace of one-ounce copper is approximately 0.5m Ω . A 1mV error can be caused by as little as 2A flowing through this small interconnect. This will cause a 1% error in a 100mV signal. A 10A load current in the same interconnect will cause a 5% error for the same 100mV signal. By isolating the sense traces from the high current paths, this error can be reduced

APPLICATIONS INFORMATION

by orders of magnitude. A sense resistor with integrated Kelvin sense terminals will give the best results. Figure 2 illustrates the recommended method.

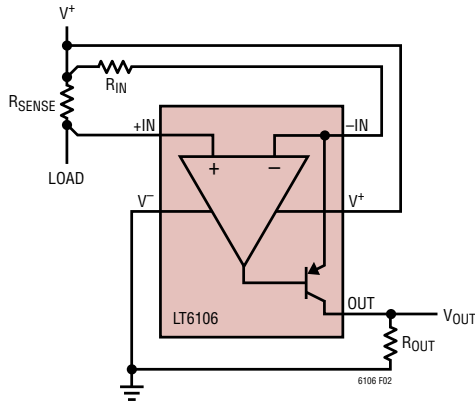

Figure 2. Kelvin Input Connection Preserves Accuracy with Large Load Currents

Selection of External Input Resistor, R_{IN}

R_{IN} should be chosen to allow the required resolution while limiting the output current to 1mA. In addition, the maximum value for R_{IN} is 500Ω. By setting R_{IN} such that the largest expected sense voltage gives I_{OUT} = 1mA, then the maximum output dynamic range is available. Output dynamic range is limited by both the maximum allowed output current and the maximum allowed output voltage, as well as the minimum practical output signal. If less dynamic range is required, then R_{IN} can be increased accordingly, reducing the maximum output current and power dissipation. If low sense currents must be resolved accurately in a system that has a very wide dynamic range, a smaller R_{IN} than the maximum current spec allows may be used if the maximum current is limited in another way, such as with a Schottky diode across R_{SENSE} (Figure 3). This will reduce the high current measurement accuracy by limiting the result, while increasing the low current measurement resolution.

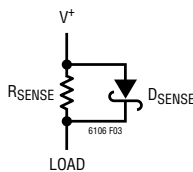

Figure 3. Shunt Diode Limits Maximum Input Voltage to Allow Better Low Input Resolution Without Overranging

This approach can be helpful in cases where occasional bursts of high currents can be ignored.

Care should be taken when designing the board layout for R_{IN}, especially for small R_{IN} values. All trace and interconnect resistances will increase the effective R_{IN} value, causing a gain error.

Selection of External Output Resistor, R_{OUT}

The output resistor, R_{OUT}, determines how the output current is converted to voltage. V_{OUT} is simply I_{OUT} • R_{OUT}.

In choosing an output resistor, the maximum output voltage must first be considered. If the following circuit is a buffer or ADC with limited input range, then R_{OUT} must be chosen so that I_{OUT(MAX)} • R_{OUT} is less than the allowed maximum input range of this circuit.

In addition, the output impedance is determined by R_{OUT}. If the circuit to be driven has high enough input impedance, then almost any useful output impedance will be acceptable. However, if the driven circuit has relatively low input impedance, or draws spikes of current such as an ADC might do, then a lower R_{OUT} value may be required in order to preserve the accuracy of the output. As an example, if the input impedance of the driven circuit is 100 times R_{OUT}, then the accuracy of V_{OUT} will be reduced by 1% since:

$$V_{OUT} = I_{OUT} \cdot \frac{R_{OUT} \cdot R_{IN(DRIVEN)}}{R_{OUT} + R_{IN(DRIVEN)}}$$

$$= I_{OUT} \cdot R_{OUT} \cdot \frac{100}{101} = 0.99 \cdot I_{OUT} \cdot R_{OUT}$$

Error Sources

The current sense system uses an amplifier and resistors to apply gain and level shift the result. The output is then dependent on the characteristics of the amplifier, such as gain and input offset, as well as resistor matching.

Ideally, the circuit output is:

$$V_{OUT} = V_{SENSE} \cdot \frac{R_{OUT}}{R_{IN}}; V_{SENSE} = R_{SENSE} \cdot I_{SENSE}$$

In this case, the only error is due to resistor mismatch, which provides an error in gain only. However, offset voltage and bias current cause additional errors.

APPLICATIONS INFORMATION

Output Error Due to the Amplifier DC Offset Voltage, V_{OS}

$$E_{OUT(VOS)} = V_{OS} \cdot \frac{R_{OUT}}{R_{IN}}$$

The DC offset voltage of the amplifier adds directly to the value of the sense voltage, V_{SENSE} . This is the dominant error of the system and it limits the low end of the dynamic range. The paragraph “Selection of External Current Sense Resistor” provides details.

Output Error Due to the Bias Currents, I_B^+ and I_B^-

The bias current I_B^+ flows into the positive input of the internal op amp. I_B^- flows into the negative input.

$$E_{OUT(IBIAS)} = R_{OUT} \left(I_B^+ \cdot \frac{R_{SENSE}}{R_{IN}} - I_B^- \right)$$

Assuming $I_B^+ \cong I_B^- = I_{BIAS}$, and $R_{SENSE} \ll R_{IN}$ then:

$$E_{OUT(IBIAS)} \cong -R_{OUT} \cdot I_{BIAS}$$

It is convenient to refer the error to the input:

$$E_{IN(IBIAS)} \cong -R_{IN} \cdot I_{BIAS}$$

For instance if I_{BIAS} is 60nA and R_{IN} is 1k, the input referred error is 60 μ V. Note that in applications where $R_{SENSE} \cong R_{IN}$, I_B^+ causes a voltage offset in R_{SENSE} that cancels the error due to I_B^- and $E_{OUT(IBIAS)} \cong 0mV$. In most applications, $R_{SENSE} \ll R_{IN}$, the bias current error can be similarly reduced if an external resistor $R_{IN}^+ = (R_{IN} - R_{SENSE})$ is connected as shown in Figure 4. Under both conditions:

$$E_{IN(IBIAS)} = \pm R_{IN} \cdot I_{OS}; \text{ where } I_{OS} = I_B^+ - I_B^-$$

If the offset current, I_{OS} , of the LT6106 amplifier is 6nA, the 60 μ V error above is reduced to 6 μ V.

Adding R_{IN}^+ as described will maximize the dynamic range of the circuit. For less sensitive designs, R_{IN}^+ is not necessary.

Output Error Due to Gain Error

The LT6106 exhibits a typical gain error of -0.25% at 1mA output current. The primary source of gain error is due to the finite gain to the PNP output transistor, which results in a small percentage of the current in R_{IN} not appearing in the output load R_{OUT} .

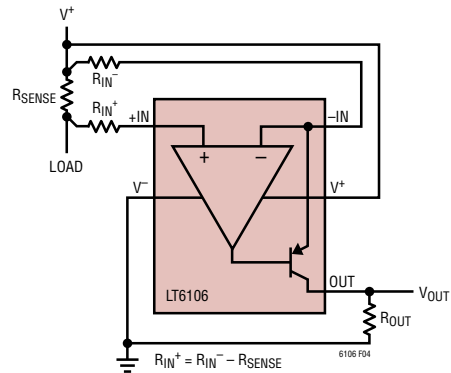

Figure 4. Second Input R Minimizes Error Due to Input Bias Current

Minimum Output Voltage

The curves of the Output Voltage vs Input Sense Voltage show the behavior of the LT6106 with low input sense voltages. When $V_{SENSE} = 0V$, the output voltage will always be slightly positive, the result of input offset voltages and of a small amount of quiescent current (0.7 μ A to 1.2 μ A) flowing through the output device. The minimum output voltage in the Electrical Characteristics table include both these effects.

Power Dissipation Considerations

The power dissipated by the LT6106 will cause a small increase in the die temperature. This rise in junction temperature can be calculated if the output current and the supply current are known.

The power dissipated in the LT6106 due to the output signal is:

$$P_{OUT} = (V_{IN}^- - V_{OUT}) \cdot I_{OUT}$$

Since $V_{IN}^- \cong V^+$, $P_{OUT} \cong (V^+ - V_{OUT}) \cdot I_{OUT}$

The power dissipated due to the quiescent supply current is:

$$P_Q = I_S \cdot (V^+ - V^-)$$

The total power dissipated is the output dissipation plus the quiescent dissipation:

$$P_{TOTAL} = P_{OUT} + P_Q$$

The junction temperature is given by:

$$T_J = T_A + \theta_{JA} \cdot P_{TOTAL}$$

At the maximum operating supply voltage of 36V and the maximum guaranteed output current of 1mA, the total

APPLICATIONS INFORMATION

power dissipation is 41mW. This amount of power dissipation will result in a 10°C rise in junction temperature above the ambient temperature.

It is important to note that the LT6106 has been designed to provide at least 1mA to the output when required, and can deliver more depending on the conditions. Care must be taken to limit the maximum output current by proper choice of sense resistor and R_{IN} and, if input fault conditions exist, external clamps.

Output Filtering

The output voltage, V_{OUT} , is simply $I_{OUT} \cdot Z_{OUT}$. This makes filtering straightforward. Any circuit may be used which generates the required Z_{OUT} to get the desired filter response. For example, a capacitor in parallel with R_{OUT} will give a lowpass response. This will reduce unwanted noise from the output, and may also be useful as a charge reservoir to keep the output steady while driving a switching circuit such as a MUX or ADC. This output capacitor in parallel with an output resistor will create a pole in the output response at:

$$f_{-3dB} = \frac{1}{2 \cdot \pi \cdot R_{OUT} \cdot C_{OUT}}$$

Useful Equations

Input Voltage: $V_{SENSE} = I_{SENSE} \cdot R_{SENSE}$

Voltage Gain: $\frac{V_{OUT}}{V_{SENSE}} = \frac{R_{OUT}}{R_{IN}}$

Current Gain: $\frac{I_{OUT}}{I_{SENSE}} = \frac{R_{SENSE}}{R_{IN}}$

Transconductance: $\frac{I_{OUT}}{V_{SENSE}} = \frac{1}{R_{IN}}$

Transimpedance: $\frac{V_{OUT}}{I_{SENSE}} = R_{SENSE} \cdot \frac{R_{OUT}}{R_{IN}}$

Power Supply Connection

For normal operation, the V^+ pin should be connected to either side of the sense resistor. Either connection will meet the constraint that $+IN \leq V^+$ and $-IN \leq V^+$. During

normal operation, V_{SENSE} should not exceed 500mV (see $V_{SENSE(MAX)}$ under Electrical Characteristics). This additional constraint can be stated as $V^+ - (+IN) \leq 500mV$. Referring to Figure 5, feedback will force the voltages at the inputs $-IN$ and $+IN$ to be equal to $(V_S - V_{SENSE})$. Connecting V^+ to the load side of the shunt results in equal voltages at $+IN$, $-IN$ and V^+ . Connecting V^+ to the supply end of the shunt results in the voltages at $+IN$ and $-IN$ to be V_{SENSE} below V^+ .

If the V^+ pin is connected to the supply side of the shunt resistor the supply current drawn by the LT6106 is not included in the monitored current. If the V^+ pin is connected to the load side of the shunt resistor (Figure 5), the supply current drawn by the LT6106 is included in the monitored current. It should be noted that in either configuration, the output current of the LT6106 will not be monitored since it is drawn through the R_{IN} resistor. Contact the factory for operation of the LT6106 with a V^+ outside of the recommended operating range.

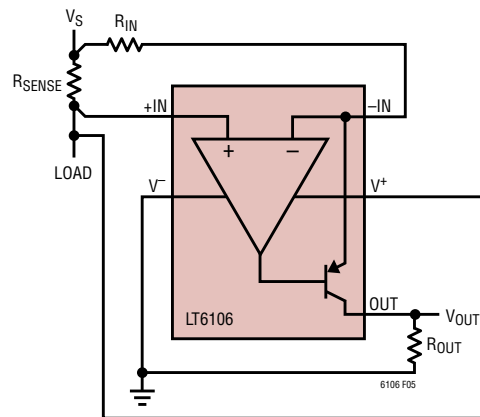

Figure 5. LT6106 Supply Current Monitored with the Load

Reverse Supply Protection

Some applications may be tested with reverse-polarity supplies due to an expectation of the type of fault during operation. The LT6106 is not protected internally from external reversal of supply polarity. To prevent damage that may occur during this condition, a Schottky diode should be added in series with V^- (Figure 6). This will limit the reverse current through the LT6106. Note that this diode will limit the low voltage performance of the LT6106 by effectively reducing the supply voltage to the part by V_D .

Rev. D

APPLICATIONS INFORMATION

In addition, if the output of the LT6106 is wired to a device that will effectively short it to high voltage (such as through an ESD protection clamp) during a reverse supply condition, the LT6106's output should be connected through a resistor or Schottky diode (Figure 7).

Demo Board

Demo board DC1240 is available for evaluation of the LT6106.

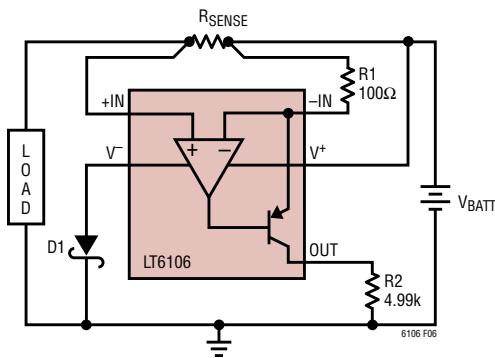

Figure 6. Schottky Diode Prevents Damage During Supply Reversal

Response Time

The photos in the Typical Performance Characteristics show the response of the LT6106 to a variety of input conditions and values of R_{IN} . The photos show that if the output current is very low or zero and an input transient occurs, there will be an increased delay before the output voltage begins changing while internal nodes are being charged.

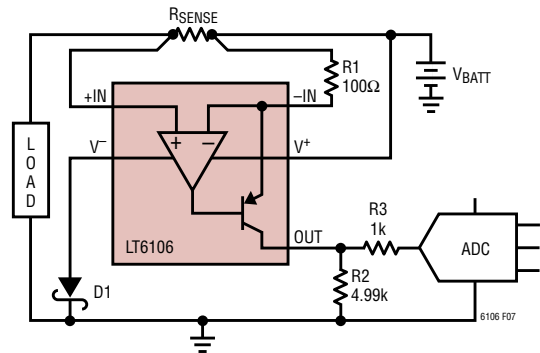
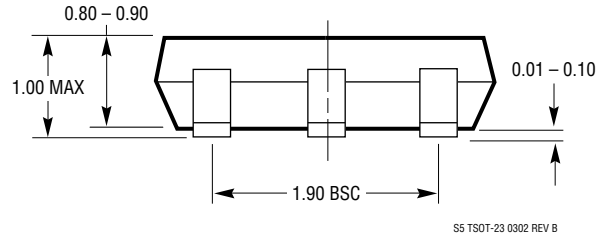
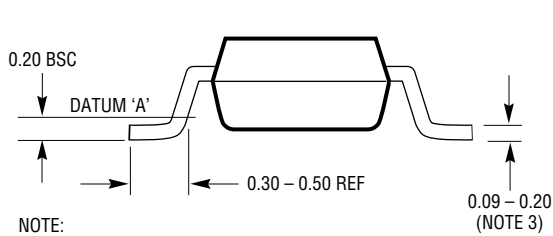
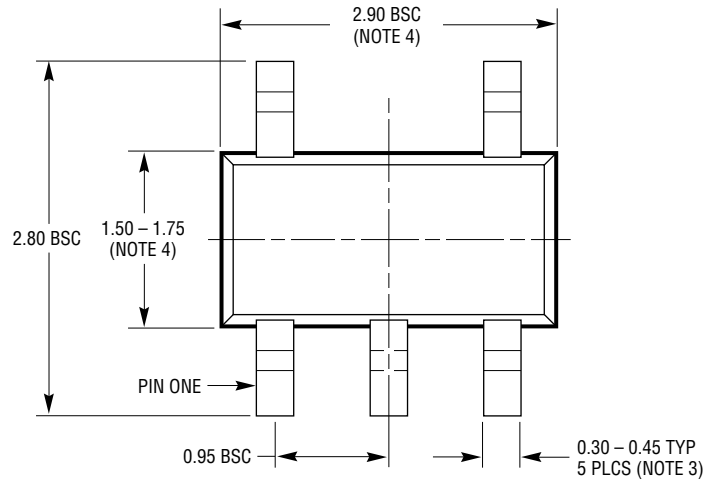
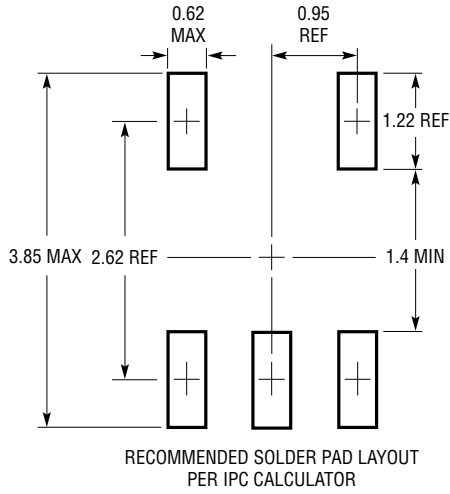

Figure 7. Additional Resistor R3 Protects Output During Supply Reversal

PACKAGE DESCRIPTION

S5 Package
5-Lead Plastic TSOT-23
 (Reference LTC DWG # 05-08-1635 Rev B)



- NOTE:
1. DIMENSIONS ARE IN MILLIMETERS
 2. DRAWING NOT TO SCALE
 3. DIMENSIONS ARE INCLUSIVE OF PLATING
 4. DIMENSIONS ARE EXCLUSIVE OF MOLD FLASH AND METAL BURR
 5. MOLD FLASH SHALL NOT EXCEED 0.254mm
 6. JEDEC PACKAGE REFERENCE IS MO-193

S5 TSOT-23 0302 REV B

REVISION HISTORY (Revision history begins at Rev B)

REV	DATE	DESCRIPTION	PAGE NUMBER
B	03/16	Reformat of Order Information.	2
		Addition of industrial temp (I) version.	2, 3
		Addition of Web links.	All
		Reformat of Package Description information.	12
		Related Parts list updated and appended.	14
C	03/20	Addition of Automotive Qualified Parts	All
D	06/26	Updated Maximum to Full Scale Output Current	1, 2

TYPICAL APPLICATION

Simple 400V Current Monitor

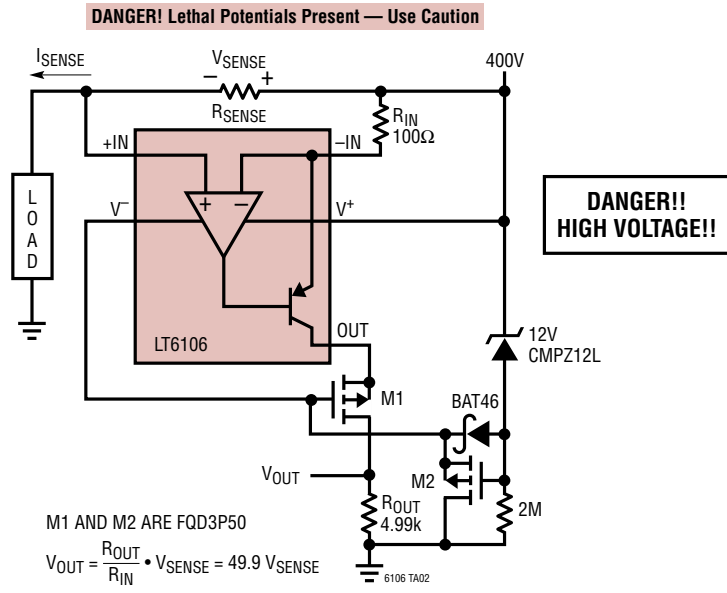

RELATED PARTS

PART NUMBER	DESCRIPTION	COMMENTS
LT1787	Bidirectional High Side Current Sense Amplifier	V_{IN} : 2.7V to 60V, 75μV Offset, 8V/V Gain
LTC4150	Coulomb Counter/Battery Gas Gauge	Indicates Charge Quantity and Polarity
LT6100	Gain-Selectable High Side Current Sense Amplifier	V_{IN} : 4.1V to 48V, Gain Settings: 10V, 12.5V, 20V, 25V, 40V, 50V/V
LTC6101	High Voltage High Side Current Sense Amplifier	V_{IN} : 4V to 100V, Resistor-Set Gain, 300μV Offset, SOT-23
LTC6102	Zero-Drift High Side Current Sense Amplifier	V_{IN} : 4V to 100V, Resistor-Set Gain, 10μV Offset, MSOP8/DFN
LTC6103	Dual High Side Current Sense Amplifier	V_{IN} : 4V to 60V, Resistor-Set Gain, Independent Amps, MSOP8
LTC6104	Bidirectional High Side Current Sense Amplifier	V_{IN} : 4V to 60V, Resistor-Set Gain Each Direction, MSOP8
LT6105	High Side or Low Side Current Sense Amplifier	V_{IN} : -0.3V to 44V, 300μV Offset, Resistor-Set Gain
LT6107	High Temp High Side Current Sense Amplifier	V_{IN} : 2.7V to 36V, 250μV Offset, -55°C to 150°C
LT6108	High Side Current Sense Amplifier, Reference and Comparator with Shutdown	V_{IN} : 2.7V to 60V, 125μV Offset, Resistor-Set Gain, ±1.25% Threshold Error
LT6109	High Side Current Sense Amplifier, Reference and 2 Comparators with Shutdown	V_{IN} : 2.7V to 60V, 125μV Offset, Resistor-Set Gain, ±1.25% Threshold Error
LT6118	High Side Current Sense Amplifier, Reference and Comparator with Power-On Reset Capability	V_{IN} : 2.7V to 60V, 200μV Offset, Resistor-Set Gain, ±1.25% Threshold Error
LT6119	High Side Current Sense Amplifier, Reference and 2 Comparators with Power-On Reset Capability	V_{IN} : 2.7V to 60V, 200μV Offset, Resistor-Set Gain, ±1.25% Threshold Error