

E-Band, Upconverter SiP, 71GHz to 86GHz

FEATURES

- ▶ **Maximum conversion gain: 42dB**
- ▶ **Gain tuning range: 32dB minimum**
- ▶ **P_{SAT}: 30dBm**
- ▶ **OIP3: 36dBm at total P_{OUT} at 20dBm**
- ▶ **OP1dB: 28dBm**
- ▶ **Three-wire SPI control for power-up/power-down and bias adjust**
- ▶ **Multiple envelope/power detectors in signal chain**
- ▶ **Built-in temperature sensors**
- ▶ **Independent analog VGA and PA bias adjust**
- ▶ **Surface-mount, 20mm × 19mm, LGA_CAV package**

APPLICATIONS

- ▶ **E-band communication systems**
- ▶ **High-capacity wireless backhauls**
- ▶ **Satellite feeder link**

GENERAL DESCRIPTION

The ADMV7315 is a fully-integrated, system-in-package (SiP), in-phase/quadrature (I/Q) upconverter that operates over an intermediate frequency (IF) input range of DC to 5GHz and a radio frequency (RF) output range of 71GHz to 86GHz. The device uses an image rejection mixer driven by a 6× local oscillator (LO) multiplier chain. The mixer RF output is followed by a variable gain amplifier (VGA) and two power amplifiers PA_A (PA1) and PA_B (PA2), providing a conversion gain of 42dB typical. A single envelope detector and power detectors are integrated within each variable gain amplifier and PA_B power amplifier to detect power levels and enable a reference for LO nulling. Differential I and Q mixer inputs are provided, and can be driven with differential I and Q baseband waveforms for direct conversion applications. Alternatively, the inputs can be driven using an external 90° hybrid and two external 180° hybrids for single-ended applications.

The ADMV7315 comes in a fully-integrated, surface-mount, 75-terminal, 20mm × 19mm, land-grid array (LGA) package. The ADMV7315 operates over the -40°C to +85°C temperature range.

For more information on the ADMV7315, contact eband@analog.com.

E-Band, Upconverter SiP, 71GHz to 86GHz

FUNCTIONAL BLOCK DIAGRAM

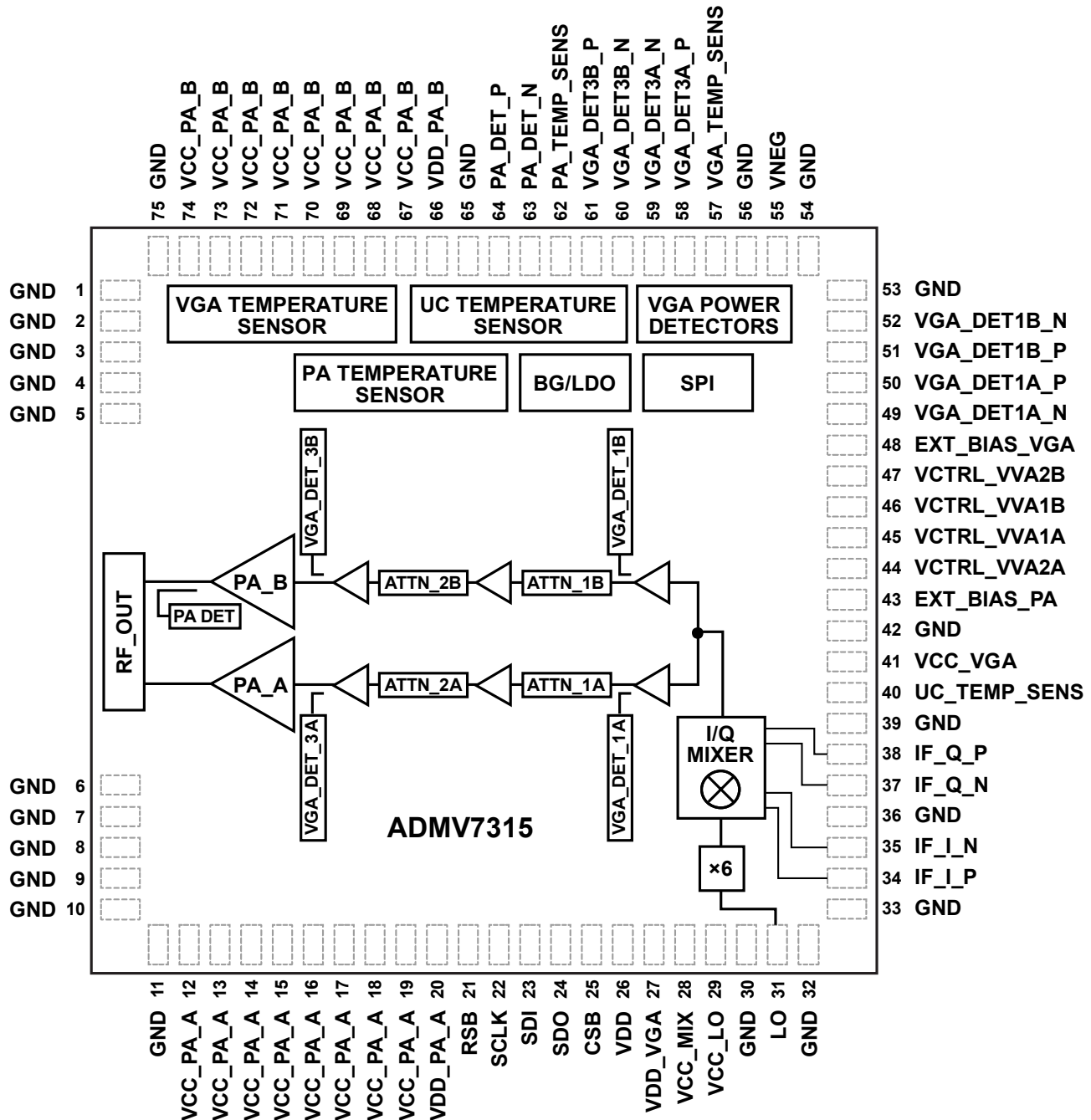

Figure 1. Functional Block Diagram

001

ALL INFORMATION CONTAINED HEREIN IS PROVIDED “AS IS” WITHOUT REPRESENTATION OR WARRANTY. NO RESPONSIBILITY IS ASSUMED BY ANALOG DEVICES FOR ITS USE, NOR FOR ANY INFRINGEMENTS OF PATENTS OR OTHER RIGHTS OF THIRD PARTIES THAT MAY RESULT FROM ITS USE. SPECIFICATIONS ARE SUBJECT TO CHANGE WITHOUT NOTICE. NO LICENCE, EITHER EXPRESSED OR IMPLIED, IS GRANTED UNDER ANY ADI PATENT RIGHT, COPYRIGHT, MASK WORK RIGHT, OR ANY OTHER ADI INTELLECTUAL PROPERTY RIGHT RELATING TO ANY COMBINATION, MACHINE, OR PROCESS, IN WHICH ADI PRODUCTS OR SERVICES ARE USED. TRADEMARKS AND REGISTERED TRADEMARKS ARE THE PROPERTY OF THEIR RESPECTIVE OWNERS. ALL ANALOG DEVICES PRODUCTS CONTAINED HEREIN ARE SUBJECT TO RELEASE AND AVAILABILITY.