

MAX2029 Evaluation Kit

Evaluates: MAX2029

General Description

The MAX2029 evaluation kit (EV kit) simplifies the evaluation of the MAX2029 815MHz to 1000MHz RF frequency range, GSM/cellular base-station transmitter, or receiver application MAX2029 upconversion/downconversion mixer. It is fully assembled and tested at the factory. Standard 50Ω SMA connectors are included on the EV kit's input and output ports to allow quick and easy evaluation on the test bench.

This document provides a list of test equipment required to evaluate the device, a straight-forward test procedure to verify functionality, a description of the EV kit circuit, the circuit schematic, a bill of materials (BOM) for the kit, and images for each layer of the PC board.

Features

- Fully Assembled and Tested
- 50Ω SMA Connectors on Input and Output Ports
- 815MHz to 1000MHz RF Frequency Range
- 570MHz to 900MHz LO Frequency Range
- 960MHz to 1180MHz LO Frequency Range (Refer to the MAX2029 Data Sheet)
- DC to 250MHz IF Frequency Range
- 6dB/6.5dB (Upconverter/Downconverter) Conversion Loss
- 36.5dBm/39dBm (Downconverter/Upconverter) Input IP3
- +25dBm/+27dBm (Upconverter/Downconverter) Input 1dB Compression Point
- 6.7dB Noise Figure
- Integrated LO Buffer
- Integrated RF and LO Baluns
- Low -3dBm to +3dBm LO Drive
- Built-In SPDT LO Switch with 43dB LO1 to LO2 Isolation and 50ns Switching Time
- External Current-Setting Resistor Provides Option for Operating Mixer in Reduced Power/Reduced Performance Mode

Ordering Information appears at end of data sheet.

Quick Start

The MAX2029 EV kit is fully assembled and factory tested. Follow the instructions in the [Connections and Setup](#) section for proper device evaluation.

Required Equipment

This section lists the recommended test equipment to verify the operation of the MAX2029. It is intended as a guide only, and substitutions can be possible:

- DC supply capable of delivering +5.0V and 175mA
- Three RF signal generators capable of delivering 10dBm of output power in the 1GHz to 3GHz frequency range (e.g., HP 8648)
- RF spectrum analyzer with a minimum 100kHz to 3GHz frequency range (HP 8561E)
- RF power meter (HP 437B)
- Power sensor (HP 8482A)

Connections and Setup

This section provides a step-by-step guide to testing the basic functionality of the EV kit. As a general precaution to prevent damaging the outputs by driving high-VSWR loads, do not turn on DC power or RF signal generators until all connections are made.

This procedure is specific to operation in the GSM/cellular band with a low side injected LO for a 90MHz IF. Choose the test frequency based on the particular system's frequency plan and adjust the following procedure accordingly.

- 1) Calibrate the power meter for 920MHz. For a safety margin, use a power sensor rated to at least +20dBm or use padding to protect the power head as necessary.
- 2) Connect 3dB pads to the DUT ends of each of the two RF signal generators' SMA cables. This padding improves VSWR and reduces the errors due to mismatch.

- 3) Use the power meter to set the RF signal generators according to the following:
 - RF signal source: 0dBm into DUT at 920MHz (this should be approximately +3dBm before the 3dB pad).
 - LO1 signal source: 0dBm into DUT at 830MHz (this should be approximately +3dBm before the 3dB pad).
 - LO2 signal source: 0dBm into DUT at 831MHz (this should be approximately +3dBm before the 3dB pad).
- 4) Disable the signal generator outputs.
- 5) Connect the RF source (with pad) to the RF port.
- 6) Connect the LO1 and LO2 signal sources to the EV kit's LO1 and LO2 inputs, respectively.
- 7) Measure the loss in the 3dB pad and cable that are going to be connected to the IF port. Losses are frequency dependent, so test this at 90MHz (the IF frequency). Use this loss as an offset in all output power/gain calculations.
- 8) Connect this 3dB pad to the EV kit's IF port connector and connect a cable from the pad to the spectrum analyzer.
- 9) Set the DC supply to +5.0V and set a current limit around 175mA if possible. Disable the output voltage and connect the supply to the EV kit (through an ammeter, if desired). Enable and readjust the supply to get +5.0V at the EV kit. There can be a voltage drop across the ammeter when the mixer is drawing current.
- 10) Select LO1 by connecting LOSEL (TP3) to GND.
- 11) Enable the LO and the RF sources.

Testing the Mixer

Adjust the center and span of the spectrum analyzer to observe the IF output tone at 90MHz. The level should be about -9dBm (6dB conversion loss, 3dB pad loss). The spectrum analyzer's absolute magnitude accuracy is typically no better than ± 1 dB; use the power meter to get an accurate output power measurement.

Disconnect the GND connection to LOSEL, it is going to be pulled high by a pullup resistor on the board to select LO2. Observe that the 91MHz signal increases while the 90MHz decreases.

Reconfigure the test setup using a combiner or hybrid to sum the two LO inputs to do a two-tone IP3 measurement if desired. Terminate the unused LO input in 50 Ω .

Detailed Description

The MAX2029 is a high-linearity upconverter/downconverter integrated with RF and LO baluns, a LO buffer, and a SPDT LO input select switch. The EV kit circuit uses the MAX2029 and consists mostly of supply-decoupling capacitors, DC-blocking capacitors, a current-setting resistor, and an IF balun. The MAX2029 EV kit circuit allows for thorough analysis and a simple design-in.

Detailed Description of Hardware

Supply-Decoupling Capacitors

Capacitors C2, C7, C8, and C11 are 82pF supply decoupling capacitors used to filter high-frequency noise. Capacitors C3, C6, and C9 are larger 0.01 μ F capacitors used for filtering lower frequency noise on the supply.

DC-Blocking Capacitors

The MAX2029 has internal baluns at the RF and LO inputs. These inputs have almost 0 Ω resistance at DC, and so DC-blocking capacitors C1, C10, and C12 are used to prevent any external bias from being shunted directly to ground.

LO Bias

Bias current for the integrated LO buffer is set with resistor R1 (523 $\Omega \pm 1\%$). The DC current of the device can be reduced by increasing the value of R1, but the device would operate at reduced performance levels (see the [Modifying the EV Kit](#) section).

Tap Network

Capacitor C5 helps to terminate the second-order intermodulation products.

IF \pm

The MAX2029 mixer has an IF frequency range of DC to 250MHz. Note that these differential ports are ideal for providing enhanced IIP2 performance. Single ended IF applications require a 1:1 balun to transform the 50 Ω differential output impedance to a 50 Ω single ended output. After the balun, the IF return loss is better than 15dB. The differential IF is used as an input port for upconverter operation. The user can use a differential IF amplifier following the mixer, but a DC block is required on both IF pins. In this configuration, the IF+ and IF- pins need to be returned to ground through high resistance (about

1kΩ). This ground return can also be accomplished by grounding the RF tap (pin 3) and AC-coupling the IF+ and IF- ports (pins 19 and 18).

LOSEL

The EV kit includes a 47kΩ pullup resistor (R2) for easy selection of the LO port. Providing a ground at TP3 selects LO1 and leaving TP3 open selects LO2. To drive TP3 from an external source, follow the limits called out in the MAX2029 device data sheet. Logic voltages should not be applied to LOSEL without the +5V supply voltage. Doing so can cause the on-chip ESD diodes to conduct and could damage the device.

Layout Considerations

The MAX2029 evaluation board can be a guide for the board layout. Pay close attention to thermal design and close placement of components to the IC. The MAX2029 package exposed paddle (EP) conducts heat from the device and provides a low-impedance electrical connection to the ground plane. The EP must be attached to the PC board ground plane with a low thermal and electrical impedance contact. Ideally, this is achieved by soldering the backside of the package directly to a top metal

ground plane on the PC board. Alternatively, the EP can be connected to an internal or bottom-side ground plane using an array of plated vias directly below the EP. The MAX2029 EV kit uses nine evenly spaced 0.016in diameter, plated-through holes to connect the EP to the lower ground planes.

Depending on the ground-plane spacing, large surface-mount pads in the IF path might need to have the ground plane relieved under them to reduce parasitic shunt capacitance.

Modifying the EV Kit

The RF, LO, and IF ports are broadband matched, so there is no need to modify the circuit for use anywhere in the 815MHz to 1000MHz RF range, 570MHz to 900MHz LO range, and DC to 250MHz IF range.

The DC current of the device can be lowered if reduced performance is acceptable. Reducing the current is accomplished by increasing the value of R1. Doubling the value of R1 reduces the DC current approximately by half. Approximately 10% of the overall IC current is used for basic operation of the device (R1 set at 523Ω) and cannot be reduced.

Component List

PART	QTY	DESCRIPTION
C1, C2, C7, C8, C10, C11, C12	7	82pF ±5% 50V C0G CER CAP (0603) Murata: GRM1885C1H820J
C3, C6, C9	3	0.01µF ±10% 50V X7R CER CAP (0603) Murata: GRM188R71H103K
C5	1	3.3pF ±0.1pF 50V C0G CER CAP (0603) Murata: GRM1885C1H3R3B
C4	0	Not Installed
L1	0	Not Installed
R1	1	523Ω ±1% Resistor (0603) Any, Lead-free only
R2	1	47kΩ ±5% Resistor (0603) Any, Lead-free only
J1, J2, J3, J4	4	PCB Edge Mount SMA RF Connector (Flat tab launch) Johnson: 142-0741-85
T1	1	1:1 Transformer (50:50) M/A-COM: MABAES0029

PART	QTY	DESCRIPTION
U1	1	Active Mixer IC (5x5mm QFN20 exp paddle) Maxim: MAX2029ETP+ NOTE: U1 HAS AN EXPOSED PADDLE CONDUCTOR WHICH REQUIRES IT TO BE SOLDER ATTACHED TO A GROUNDED PAD ON THE CIRCUIT BOARD TO ENSURE A PROPER ELECTRICAL/THERMAL DESIGN
TP1	1	Large Test Point for 0.062" PCB (Red) Kobiconn: 151-107-RC Mouser: 151-107-R
TP2	1	Large Test Point for 0.062" PCB (Black) Kobiconn: 151-103-RC Mouser: 151-103-RC
TP3	1	Large Test Point for 0.062" PCB (White) Kobiconn: 151-101-RC Mouser: 151-101-R

Component Suppliers

SUPPLIER	PHONE	WEBSITE
Johnson	507-833-8822	www.johnsoncomponents.com
M/A-Com	800-366-2266	www.macom.com
Murata	770-436-1300	www.murata.com

Note: Indicate that you are using the MAX2029 when contacting these component suppliers.

Ordering Information

PART	TYPE
MAX2029EVKIT#	EV KIT

#Denotes RoHS compliant with exemption.

MAX2029 EV Kit Schematic

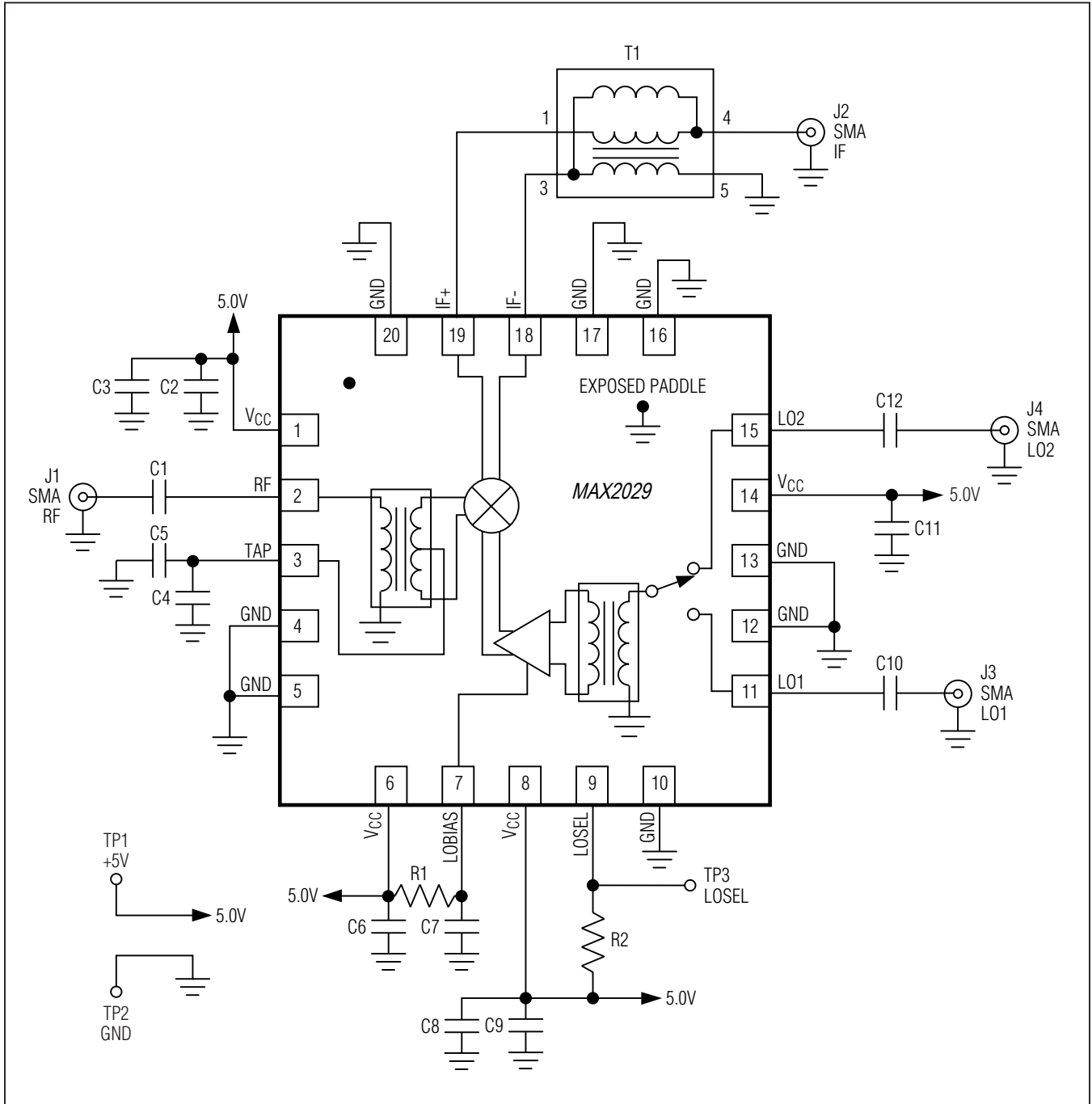

MAX2029 EV Kit PCB Layout

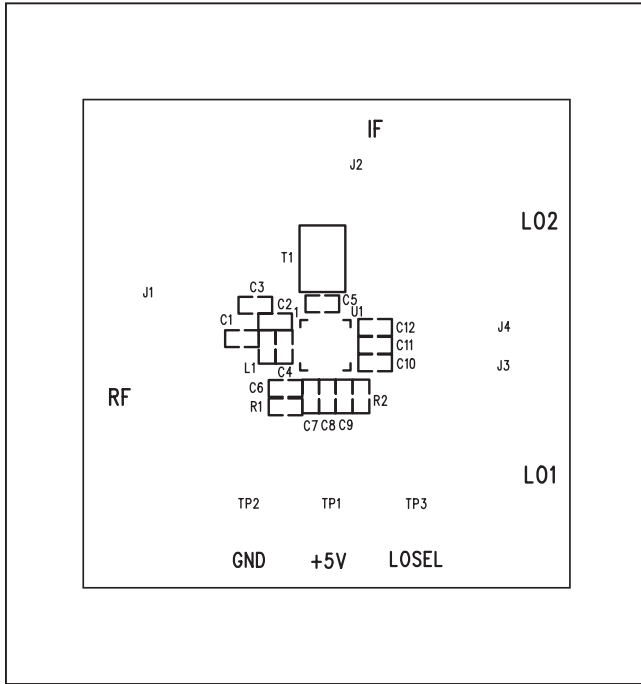

MAX2029 EV Kit PCB Layout—Top Silkscreen

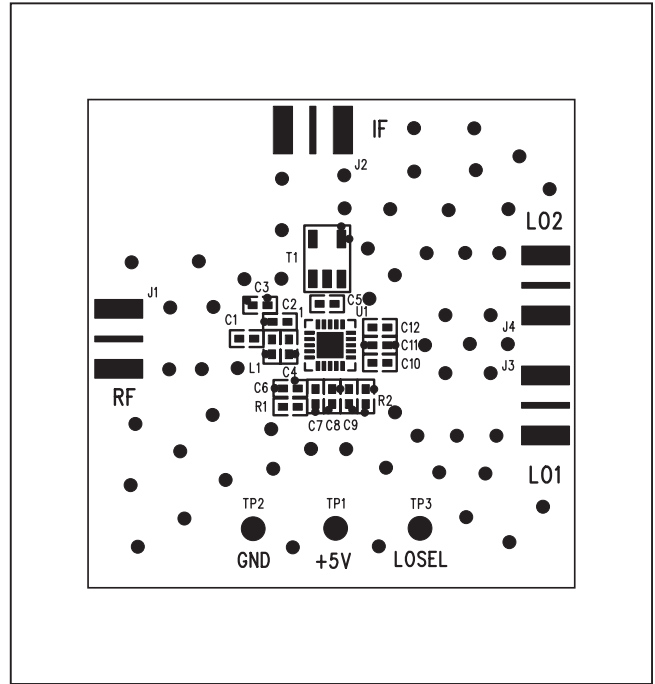

MAX2029 EV Kit PCB Layout—Top View

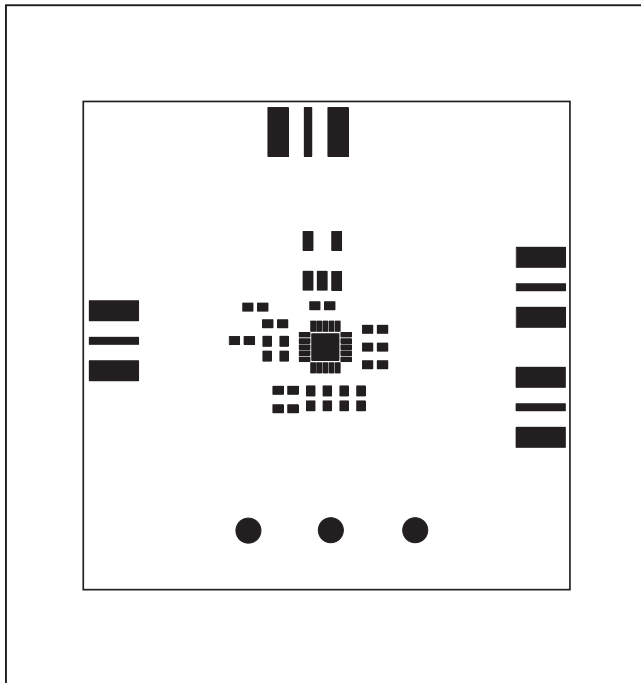

MAX2029 EV Kit PCB Layout—Top Mask

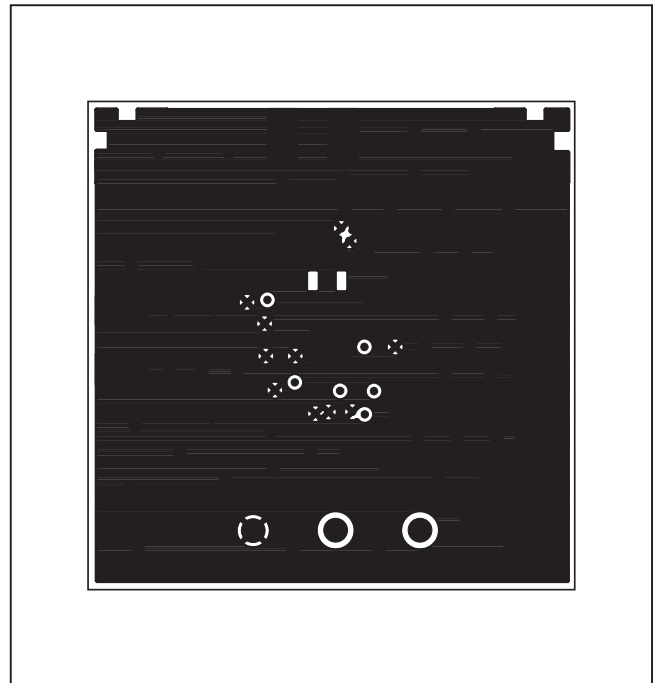

MAX2029 EV Kit PCB Layout—Layer 2

MAX2029 EV Kit PCB Layout (continued)

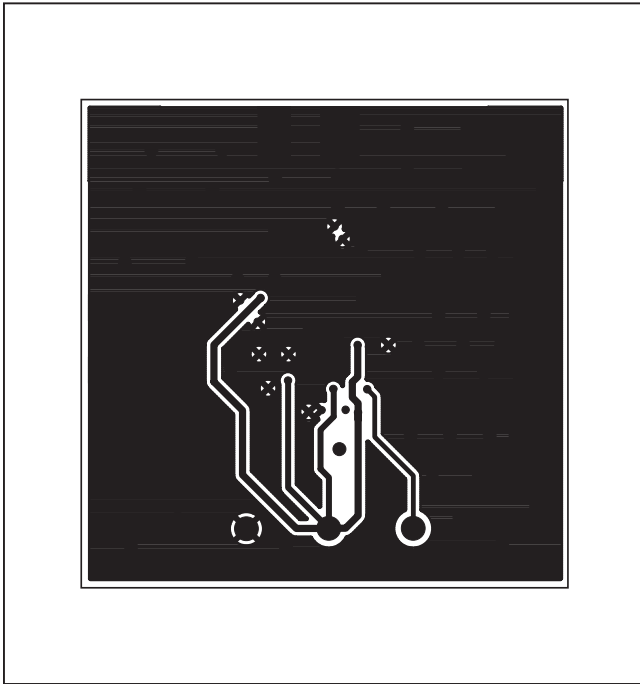

MAX2029 EV Kit PCB Layout—Layer 3

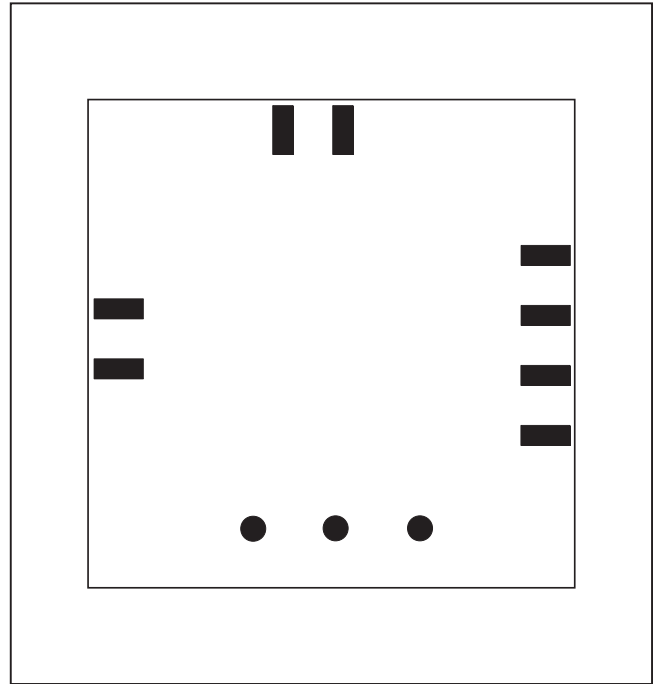

MAX2029 EV Kit PCB Layout—Bottom Mask

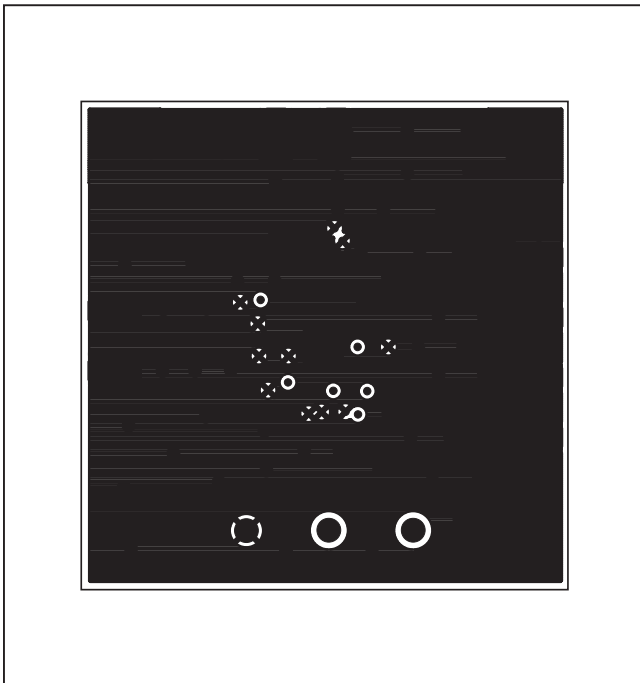

MAX2029 EV Kit PCB Layout—Bottom View

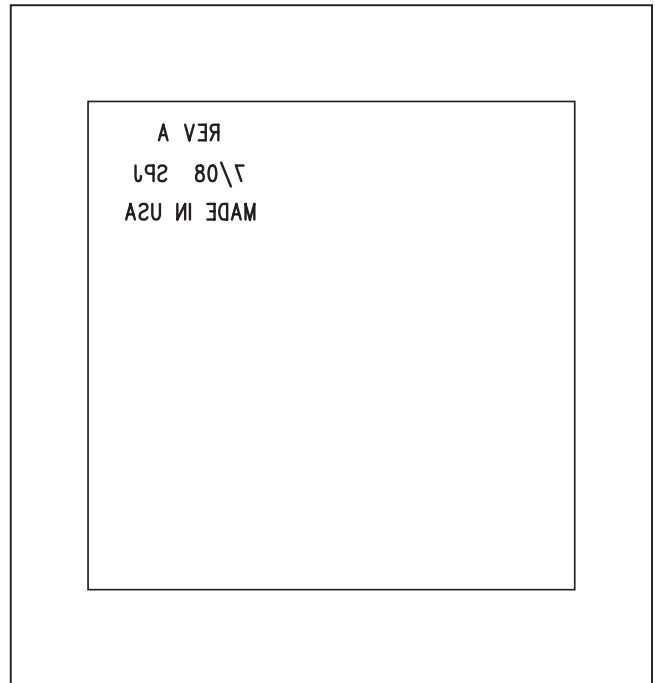

MAX2029 EV Kit PCB Layout—Bottom Silkscreen

Revision History

REVISION NUMBER	REVISION DATE	DESCRIPTION	PAGES CHANGED
0	3/21	Initial release	—

For pricing, delivery, and ordering information, please visit Maxim Integrated's online storefront at <https://www.maximintegrated.com/en/storefront/storefront.html>.

Maxim Integrated cannot assume responsibility for use of any circuitry other than circuitry entirely embodied in a Maxim Integrated product. No circuit patent licenses are implied. Maxim Integrated reserves the right to change the circuitry and specifications without notice at any time.