

### FEATURES

- Flexible board layout
- Accommodates AD8131/AD8132/AD8138/AD8139
- Accommodates various circuit configurations:
  - 4-resistor
  - Two different feedback loops
  - Input and output transformers
  - Filters

### GENERAL DESCRIPTION

An Analog Devices differential driver evaluation board makes it easy for designers to get quick performance results for their particular differential driver application circuits. The board layout is very flexible and allows for many circuit configurations, including traditional 4-resistor circuits, circuits with two different feedback loops, circuits with input and output transformers, filters, and many others. Most resistors and capacitors are in 1206 packages.

The board accommodates the [AD8131](#), [AD8132](#), [AD8138](#), and [AD8139](#). Use the data sheets for these devices with this evaluation board data sheet.

The [AD8131](#) is a special case because it has internal feedback networks but can, nonetheless, be evaluated on the board by:

- Omitting the R19 and R20 feedback resistors and C3 and C4 capacitors.
- Using 0  $\Omega$  resistors for Gain Resistor R17 and Gain Resistor R18.
- Ignoring all further references to these components.

### DIFFERENTIAL DRIVER EVALUATION BOARD SCHEMATIC

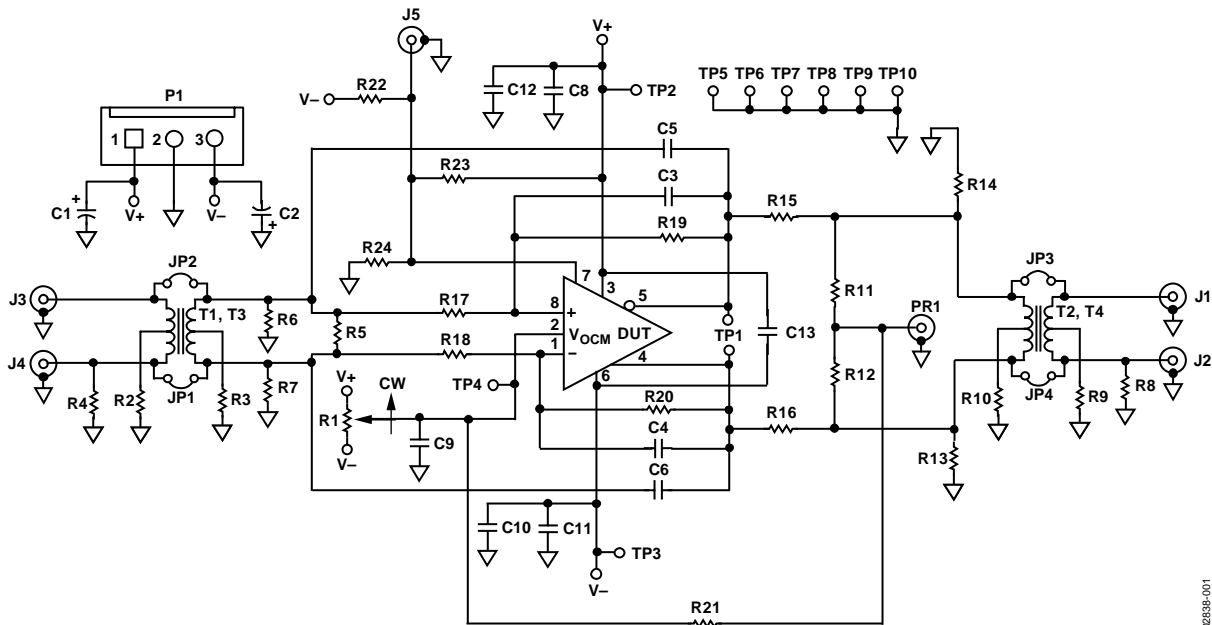

Figure 1.

#### Rev. A

Information furnished by Analog Devices is believed to be accurate and reliable. However, no responsibility is assumed by Analog Devices for its use, nor for any infringements of patents or other rights of third parties that may result from its use. Specifications subject to change without notice. No license is granted by implication or otherwise under any patent or patent rights of Analog Devices. Trademarks and registered trademarks are the property of their respective owners.

## HARDWARE

### POWER SUPPLIES

Power is applied to the board through P1, a Molex® 22-11-2032 3-pin header. Pin 1 (square footprint) is for the positive supply, Pin 3 is for the negative supply, and Pin 2 is connected to the ground plane of the board. Alternatively, looped test points can be used; Test Point TP2 connects to the positive supply, TP3 connects to the negative supply, and TP7 and TP8 connect to the ground plane. The TP5, TP6, TP9, and TP10 test points also connect to the ground plane.

The board accommodates single or dual supplies. For single-supply operation, simply connect the negative supply to the ground plane.

It is very important that the power supply pins of the device under test (DUT) have broadband decoupling circuitry. The board layout facilitates this with footprints for two 1206 ceramic capacitors on each supply. At frequencies beyond the resonant frequency of the first capacitor and its associated internal and external inductance, the second capacitor provides the required low impedance return current path. For optimum performance, place the smaller of the two capacitances closest to the DUT, in positions C8 and C11. C13 provides the user with the option of adding differential decoupling between the supplies. Bulk decoupling is provided by C1 and C2; 10  $\mu$ F tantalum capacitors are recommended.

### FEEDBACK NETWORKS AND INPUT/OUTPUT TERMINATIONS

R19 and R17 compose the upper resistive feedback loop (see Figure 1), and R20 and R18 compose the lower feedback loop. C3 and C4 are included across the feedback resistors to provide frequency-dependent feedback, typically used to introduce a real-axis pole in the closed-loop frequency response.

To minimize summing node capacitances, void the ground plane under and around Pin 1 and Pin 8 of the DUT and the copper that connects to them.

R6 and R7 are included as input termination resistors for applications that have single-ended inputs. Having a place for a shunt resistor on each input makes it simple to match the two feedback factors. A common example of how this is used is when the input signal originates from an unbalanced 50  $\Omega$  source. In this case, the single-ended termination resistance is 50  $\Omega$  and the Thevenin equivalent resistance seen looking back to the source is 25  $\Omega$ . For the traditional 4-resistor configuration, where R19 = R20 and R17 = R18, the feedback networks are matched by making the shunt resistor on the input leg opposite the termination resistor equal to 25  $\Omega$ . R5 is provided for differential termination.

R15 and R16 series termination resistors are provided on each of the outputs for impedance matching, analog-to-digital converter (ADC) driving, and other system requirements.

### V<sub>OCM</sub> INPUT

The V<sub>OCM</sub> input can be set to a dc level by adjusting Potentiometer R1 that spans the power supplies. For the dc case, C9 is provided at the wiper for decoupling.

An external voltage can be applied to V<sub>OCM</sub> via TP4 (referenced to the ground plane of the board). In ADC driving applications, it is convenient to apply the ADC dc reference voltage output directly to TP4.

It is also possible to drive the V<sub>OCM</sub> input from an external ac source. In this case, omit C9 or reduce it to a value that allows the desired signal to be passed. For high frequency signals on V<sub>OCM</sub>, connect the center conductor of a coaxial cable to TP4 and ground its shield at TP10.

R21 is provided for the high common-mode output impedance application illustrated in Figure 77 of the AD8132 data sheet.

### MEASURING OUTPUT COMMON-MODE VOLTAGE

The internal common-mode feedback loop used in the differential drivers forces the output common-mode voltage to be equal to the voltage applied to the V<sub>OCM</sub> input, thereby providing excellent output balance. R11 and R12 form a voltage divider across the differential output, and the voltage at the divider tap is equal to the output common-mode voltage, provided R11 and R12 are exactly matched in value. If R11 and R12 are used to evaluate the output common-mode voltage, they should be measured and matched to better than 300 ppm to obtain results commensurate with the DUT output balance error performance of -70 dB. The Test Point PR1 accepts coaxial-type oscilloscope test points, such as the Berg Electronics 33JR135-1.

### INPUT/OUTPUT TRANSFORMERS

The board has the added flexibility of allowing the user to incorporate transformers on its input and output. This capability can be especially useful when connecting to single-ended test equipment. Because both input and output transformers have dual, nested footprints, the user can select from a wide array of transformers available from companies such as Mini-Circuits® and Coilcraft®. The layout provides footprints for connecting resistors to ground on the primary and secondary transformer center taps, offering the user a number of options with regard to the common-mode properties of the evaluation circuit.

JP1, JP2, JP3, and JP4 are jumpers on the backside of the board that provide direct shunts across their associated transformers.

When not using a transformer, bypassing the transformer is a simple matter of shorting the appropriate jumpers. Clearly, when using a transformer, it is a good idea to verify that the associated jumpers are open.

## **SMA INPUT/OUTPUT CONNECTORS**

The inputs and outputs have edge-mounted SMA connectors for straightforward connection to coaxial cables. The recommended connector type is Johnson Components™ part number 142-0701-801, or equivalent.

## **OTHER COMPONENTS**

The components discussed in this data sheet pertain mostly to traditional amplifier topologies. There are footprints provided for a number of other components on the board to allow the

user to be more creative than the traditional designs. Clearly, a component labeled as a capacitor need not be a capacitor provided it fits the user's application circuit and to the footprint on the board.

In application circuits where footprints for desired components are not available on the board, the user is encouraged to find ways to include them. For example, if an additional shunt element were required, the user could scrape some solder mask away from the ground plane and trace (if necessary) to make a place for the additional part. Furthermore, 1206 elements can be stacked on top of each other to implement a parallel circuit. An example of this would be stacking capacitors across R17 and R18 to realize a zero in the closed-loop transfer function. This is one way to insert pre-emphasis in a line-driver application.

# EVAL-ADDIFFAMP

## ORDERING INFORMATION

### ORDERING GUIDE

Model	Description
EVAL-ADDIFFAMP-1R	Differential Driver Evaluation Board (SOIC)
EVAL-ADDIFFAMP-1RM	Differential Driver Evaluation Board (MSOP)

### ESD CAUTION

ESD (electrostatic discharge) sensitive device. Electrostatic charges as high as 4000 V readily accumulate on the human body and test equipment and can discharge without detection. Although this product features proprietary ESD protection circuitry, permanent damage may occur on devices subjected to high energy electrostatic discharges. Therefore, proper ESD precautions are recommended to avoid performance degradation or loss of functionality.



## REVISION HISTORY

### 1/06—Rev. 0 to Rev. A

Updated Format ..... Universal

Change to Figure 1 ..... 1

### 10/03—Revision 0: Initial Version