

REVISION RECORD		
REV	DESCRIPTION	DATE
0	INITIAL RELEASE	06/15/00
A	PAGE 12, ADDED VERBIAGE TO HEADING OF TABLE II	12/11/00
B	<ul style="list-style-type: none"> REMOVED THE “M” FROM THE DEVICE TITLE, THROUGHOUT THE SPEC, TO MATCH THE DATA SHEET AND RPL. PAGE 3, PARAGRAPH 3.7.1, CHANGED THE DOSAGE RATE FROM “APPROXIMATELY 20 RADS PER SECOND” TO “LESS THAN OR EQUAL TO 10 RADS PER SECOND”. PAGE 4, PARAGRAPH 6.1 CHANGED QUALITY ASSURANCE PROVISIONS TO STATE THAT LTC IS QML CERTIFIED AND THAT RAD HARD CANDIDATES ARE ASSEMBLED ON QUALIFIED CLASS S MANUFACTURING LINES. PAGES 6 THROUGH 10, ALL FIGURE TITLES CHANGED TO HAVE DEVICE OPTIONS AND PACKAGE TYPES AT TOP OF PAGE, AND HAVE ALL FIGURES AT BOTTOM OF PAGE. CONVERSION OF SPECIFICATION FROM WORD PERFECT TO MICROSOFT WORD. 	07/16/02
C	<ul style="list-style-type: none"> PAGE 3, CHANGED INITIAL RATE OF RADS TO 240 RADS/SEC. 	03/21/05
D	<ul style="list-style-type: none"> PAGE 3, PARAGRAPH 3.7.1 CHANGED VERBIAGE. 	05/05/08
E	<ul style="list-style-type: none"> PAGE 13, CHANGED RH CANNED SAMPLE TABLE III FOR QUALIFYING DICE SALES ADDED TEMPERATURE CYCLE, CONSTANT ACCELERATION & REMOVED PIND TEST. 	02/10/09
F	Page 2, amended section 3.3, <u>Special Handling of Dice</u> , to more accurately describe our current procedures and requirements.	03/30/12
G	Page 13, Changed RH Canned Sample Table for Qualifying Dice Sales: Subgroup 6 Sample Size Series changed from 45 (3) to 65 (3). First note had the Sample Size Series from “15%” to “10%”.	07/02/13
H	Updated Die Sales table on pg 13.	05/22/15
J	Changed cage code from 94155 to 64155	08/28/17
K	Replace burnin circuit in figure 3 to reflect changes to burn-in ambient temperature and addition of thermal shutdown temperature	12/01/17
L	Removed Source Inspection (6.4.1)	01/15/19

CAUTION: ELECTROSTATIC DISCHARGE SENSITIVE PART

REVISION	PAGE NO.	1	2	3	4	5	6	7	8	9	10	11	12	13	14		
INDEX	REVISION	L	L	L	L	L	L	L	L	L	L	L	L	L	L		
REVISION	PAGE NO.																
INDEX	REVISION																
		ORIG								ANALOG DEVICES INC. MILPITAS, CALIFORNIA TITLE: MICROCIRCUIT, LINEAR, RH1013 DUAL PRECISION OPERATIONAL AMPLIFIER DICE							
		DSGN															
		ENGR															
		MFG															
		CM															
		QA															
		PROG									64155	05-08-5112	L				
APPLICATION	FUNCT	SIGNOFFS		DATE		CONTRACT:											

FOR OFFICIAL USE ONLY

1.0 SCOPE:

- 1.1 This specification defines the performance and test requirements for a microcircuit processed to a space level manufacturing flow.

2.0 APPLICABLE DOCUMENTS:

- 2.1 Government Specifications and Standards: the following documents listed in the Department of Defense Index of Specifications and Standards, of the issue in effect on the date of solicitation, form a part of this specification to the extent specified herein.

SPECIFICATIONS:

MIL-PRF-38535 Integrated Circuits (Microcircuits) Manufacturing, General Specification for

MIL-STD-883 Test Method and Procedures for Microcircuits

MIL-STD-1835 Microcircuits Case Outlines

- 2.2 Order of Precedence: In the event of a conflict between the documents referenced herein and the contents of this specification, the order of precedence shall be this specification, MIL-PRF-38535 and other referenced specifications.

3.0 REQUIREMENTS:

- 3.1 General Description: This specification details the requirements for the RH1013 Operational Amplifier Dice and Element Evaluation Test Samples, processed to space level manufacturing flow as specified herein.

- 3.2 Part Number: **RH1013 Dice**

- 3.3 Special Handling of Dice: Rad Hard dice require special handling as compared to standard IC dice. Rad Hard dice are susceptible to surface damage due to the absence of silicon nitride passivation that is present on most standard dice. Silicon nitride protects the dice surface from scratches by its hard and dense properties. The passivation on Linear Technology's Rad Hard dice is silicon dioxide which is much "softer" than silicon nitride. During the visual and preparation for shipment, ESD safe Tweezers are used and only the edge of the die are touched.

ADI recommends that dice handling be performed with extreme care so as to protect the die surface from scratches. If the need arises to move the die in or out of the chip shipment tray (waffle pack), use an ESD-Safe-Plastic-tipped Bent Metal Vacuum Probe, preferably .020" OD x .010" ID (for use with tiny parts). The wand should be compatible with continuous air vacuums. The tip material should be static dissipative Delrin (or equivalent) plastic.

During die attach, care must be exercised to ensure no tweezers, or other equipment, touch the top of the dice.

3.4 The Absolute Maximum Ratings:

Supply Voltage	± 22V
Differential Input Voltage	± 30V
Input Voltage	Equal to Positive Supply Voltage 5V Below Negative Supply Voltage
Output Short Circuit Duration <u>1/</u>	Indefinite
Operating Temperature Range	-55°C to 125°C
Storage Temperature Range	-65°C to 150°C
Lead Temperature (soldering, 10 sec.)	300°C

Note 1/ Parameter is guaranteed by design, characterization, or correlation to other tested parameters.

- 3.5 Design, Construction, and Physical Dimensions: Detail design, construction, physical dimensions, and electrical requirements shall be specified herein.
- 3.6 Outline Dimensions and Pad Functions: Dice outline dimensions, pad functions, and locations shall be specified in **Figure 1**.
- 3.7 Radiation Hardness Assurance (RHA):
- 3.7.1 The manufacturer shall perform a lot sample test as an internal process monitor for total dose radiation tolerance. The sample test is performed with MIL-STD-883 TM1019 Condition A as a guideline.
 - 3.7.2 For guaranteed radiation performance to MIL-STD-883, Method 1019, total dose irradiation, the manufacturer will provide certified RAD testing and report through an independent test laboratory when required as a customer purchase order line item.
 - 3.7.3 Total dose bias circuit is specified in **Figure 2**.
- 3.8 Wafer (or Dice) Probe: Dice shall be 100% probed at Ta = +25°C to the limits shown in **Table I** herein. All reject dice shall be removed from the lot. This testing is normally performed prior to dicing the wafer into chips. Final specifications after assembly are sample tested during the element evaluation.
- 3.9 Wafer Lot Acceptance: Wafer lot acceptance shall be in accordance with MIL-PRF-38535, Appendix A, except for the following: Top side glassivation thickness shall be a **minimum of 4KÅ**.
- 3.10 Wafer Lot Acceptance Report: SEM is performed per MIL-STD-883, Method 2018. Copies of SEM photographs shall be supplied with the Wafer Lot Acceptance Report as part of a Space Data Pack when specified as a customer purchase order line item.
- 3.11 Traceability: Wafer Diffusion Lot and Wafer traceability shall be maintained through Quality Conformance Inspection.
- 4.0 **QUALITY CONFORMANCE INSPECTION:** Quality Conformance Inspection shall consist of the tests and inspections specified herein.

- 5.0 **SAMPLE ELEMENT EVALUATION:** A sample from **each wafer supplying dice** shall be assembled and subjected to element evaluation per **Table III** herein.
- 5.1 100 Percent Visual Inspection: All dice supplied to this specification shall be inspected in accordance with MIL-STD-883, Method 2010, Condition A. All reject dice shall be removed from the lot.
- 5.2 Electrical Performance Characteristics for Element Evaluation: The electrical performance characteristics shall be as specified in **Table I** and **Table II** herein.
- 5.3 Sample Testing: Each wafer supplying dice for delivery to this specification shall be subjected to element evaluation sample testing. No dice shall be delivered until all the lot sample testing has been performed and the results found to be acceptable unless the customer supplies a written approval for shipment prior to completion of wafer qualification as specified in this specification.
- 5.4 Part Marking of Element Evaluation Sample Includes:
- 5.4.1 LTC Logo
 - 5.4.2 LTC Part Number
 - 5.4.3 Date Code
 - 5.4.4 Serial Number
 - 5.4.5 ESD Identifier per MIL-PRF-38535, Appendix A
 - 5.4.6 Diffusion Lot Number
 - 5.4.7 Wafer Number
- 5.5 Burn-In Requirement: Burn-In circuit for TO5 package is specified in **Figure 3**.
- 5.6 Mechanical/Packaging Requirements: Case Outline and Dimensions are in accordance with **Figure 4**.
- 5.7 Terminal Connections: The terminal connections shall be as specified in **Figure 5**.
- 5.8 Lead Material and Finish: The lead material and finish shall be Kovar with hot solder dip (Finish letter A) in accordance with MIL-PRF-38535.
- 6.0 **VERIFICATION (QUALITY ASSURANCE PROVISIONS)**
- 6.1 Quality Assurance Provisions: Quality Assurance provisions shall be in accordance with MIL-PRF-38535. Linear Technology is a QML certified company and all Rad Hard candidates are assembled on qualified Class S manufacturing lines.
- 6.2 Sampling and Inspection: Sampling and Inspection shall be in accordance with **Table III** herein.
- 6.3 Screening: Screening requirements shall be in accordance with **Table III** herein.

6.4 Source Inspection:

6.4.1 The procuring activity has the right to perform source inspection at the supplier's facility prior to shipment for each lot of deliverables when specified as a customer purchase order line item. This may include wafer lot acceptance, die visual, and final data review.

6.5 Deliverable Data: Deliverable data that will ship with devices when a Space Data Pack is ordered:

6.5.1 Lot Serial Number Sheets identifying all Canned Sample devices accepted through final inspection by serial number.

6.5.2 100% attributes (completed element evaluation traveler).

6.5.3 Element Evaluation variables data, including Burn-In and Op Life

6.5.4 SEM photographs (3.10 herein)

6.5.5 Wafer Lot Acceptance Report (3.9 herein)

6.5.6 A copy of outside test laboratory radiation report if ordered

6.5.7 Certificate of Conformance certifying that the devices meet all the requirements of this specification and have successfully completed the mandatory tests and inspections herein.

Note: Items 6.5.1 and 6.5.7 will be delivered as a minimum, with each shipment.

7.0 Packaging Requirements: Packaging shall be in accordance with Appendix A of MIL-PRF-38535. All dice shall be packaged in multicavity containers composed of conductive, anti-static, or static dissipative material with an external conductive field shielding barrier.

DICE OUTLINE DIMENSIONS AND PAD FUNCTIONS

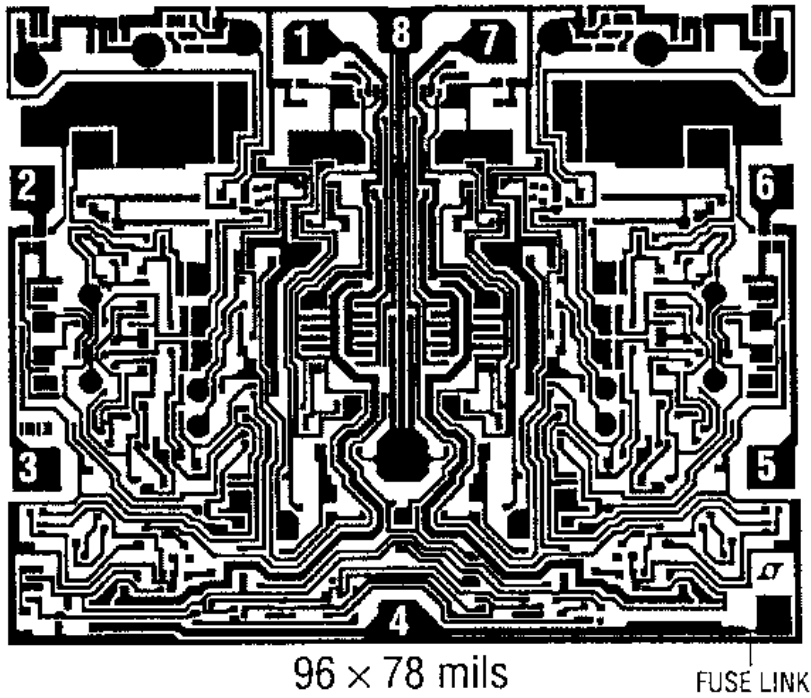

PAD FUNCTION

- 1. OUTPUT A
- 2. -INA
- 3. +INA
- 4. V⁻
- 5. +INB
- 6. -INB
- 7. OUTPUT B
- 8. V⁺

FIGURE 1

TOTAL DOSE BIAS CIRCUIT

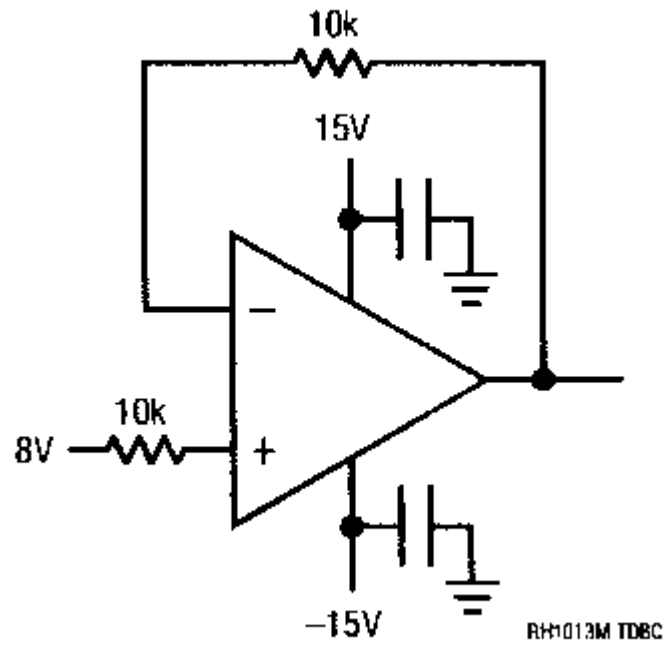

FIGURE 2

BURN-IN CIRCUIT

OVEN OPTIONS

BOARD STYLE: LTC YES
 AVI-TECH NO

LEGACY OVEN YES
 OPTIMUM OVEN YES

MCC OVEN YES
 OUTSIDE OVEN YES

RIDER CARD ASSEMBLY: N/A
 PROBE: 04-06-9252

	HARDWARE #	REV.	QUANTITY BOARDS	MAX SKTS PER BOARD
BOARD:	04-06-0035	A	1	80
EDGE CARD:	N/A			
ROW CARD:	N/A			

	MIN °C	MAX °C
AMBIENT TEMP:	125°C	133°C
JUNCTION TEMP:	137°C	141°C
AMBIENT TEMP:	150°C	158°C
JUNCTION TEMP:	162°C	166°C
THERMAL SHUTDOWN:	N/A	

<u>POWER SEQUENCE</u>				<u>DEVICE</u>			<u>EMPTY BOARD</u>			
ON	OFF	SUPPLY	MIN V	MAX V	FUSE AMPS	STARTUP CURRENT	STEADY STATE CURRENT	PER ROW CARD	PER EDGE CARD	DEDICATED BOARD PER SKT
		V1	+20.0V	+22.0V	2Amp	2mA/SKT	2mA/SKT	N/A	N/A	0mA/SKT + 50mA
		V2	-20.0V	-22.0V	2Amp	1.4mA/SKT	1.4mA/SKT	N/A	N/A	0mA/SKT + 50mA
		V3								
		V4								
		V5								

<u>TEST POINTS</u>		
T.P.#	PIN NAME	VALUE
1	OUTA	GND
2	OUTB	GND

<u>PWR/MON OPTIONS</u>	
<input checked="" type="checkbox"/> YES	V1/V4
	V2/GND

SPECIAL NOTES:
 - Do not connect V4 PWR.

CLOCKS ON VS DC	MIN V	MAX V	FREQ	DUTY CYCLE	VECTOR?

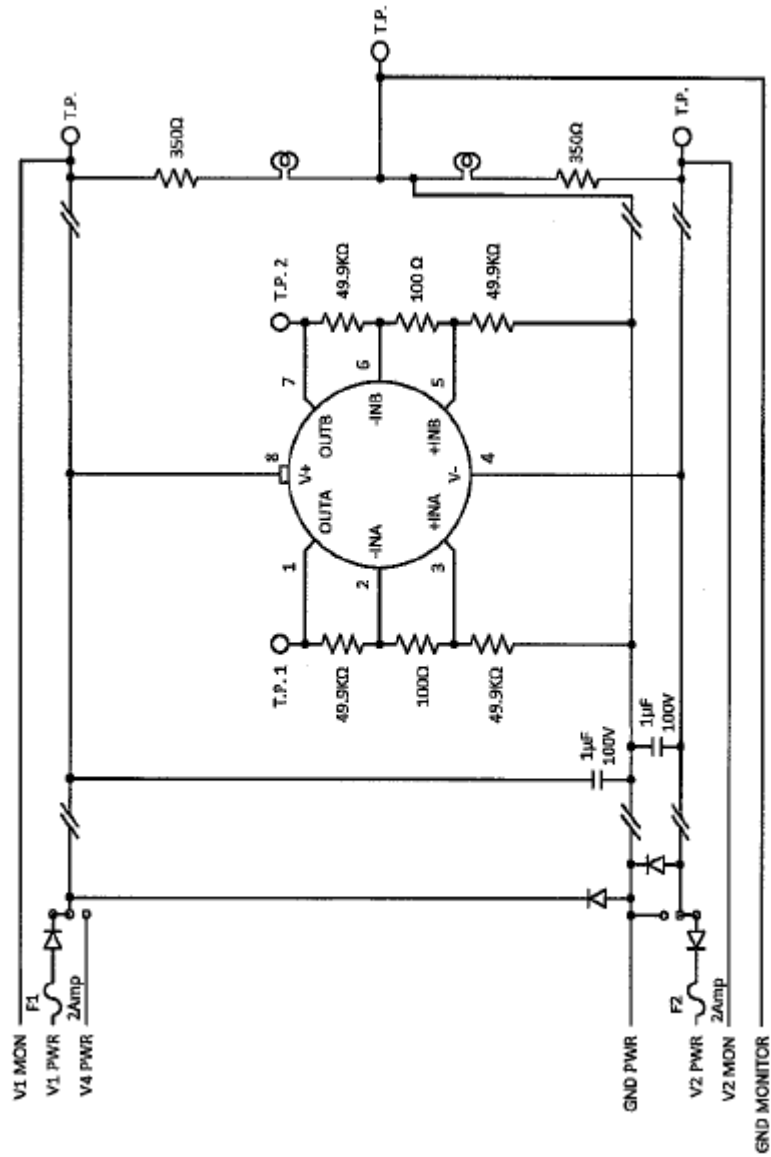
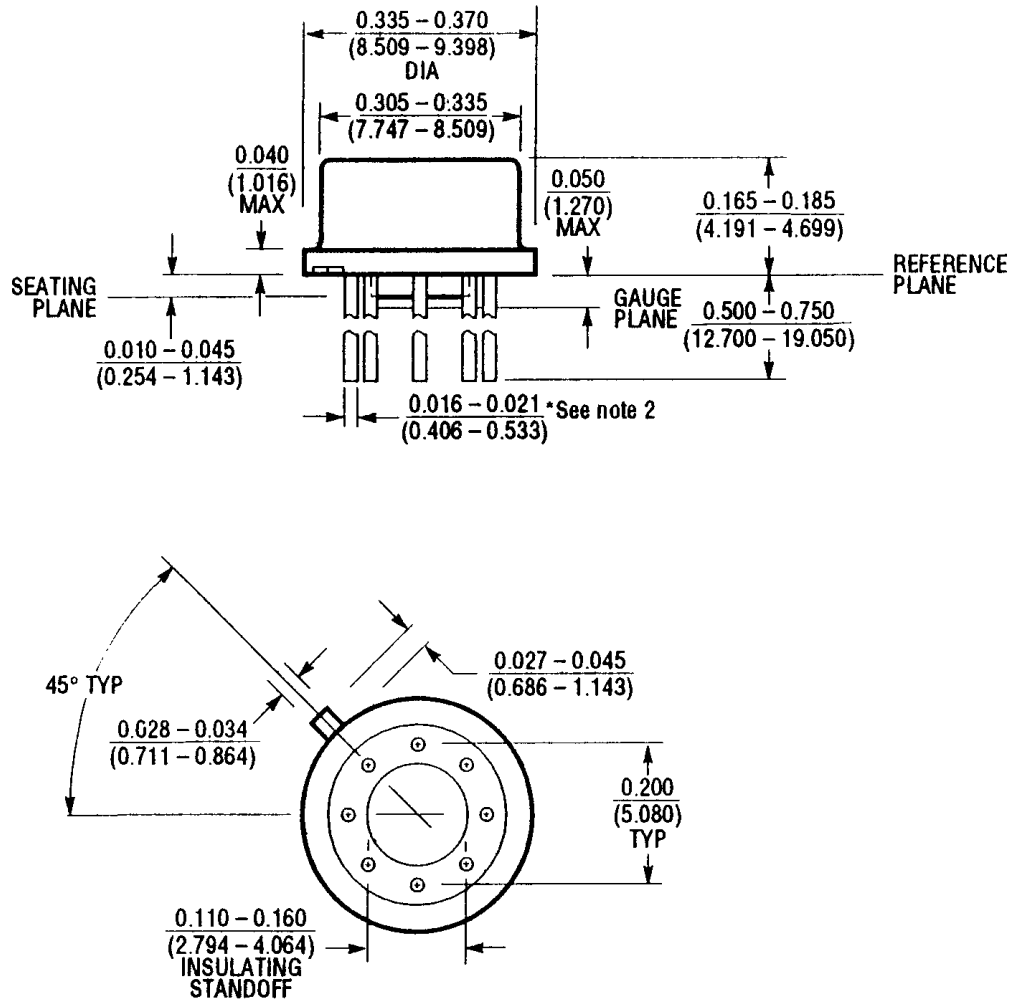

FIGURE 3

TO5, 8 LEADS, CASE OUTLINE



NOTE: 1. LEAD DIAMETER IS UNCONTROLLED BETWEEN THE REFERENCE PLANE AND SEATING PLANE.

2. FOR SOLDER DIP LEAD FINISH, LEAD DIAMETER IS $0.016 - 0.024$ (0.406 - 0.610)

FIGURE 4

$\theta_{ja} = +150^\circ\text{C/W}$
 $\theta_{jc} = +40^\circ\text{C/W}$

TERMINAL CONNECTIONS

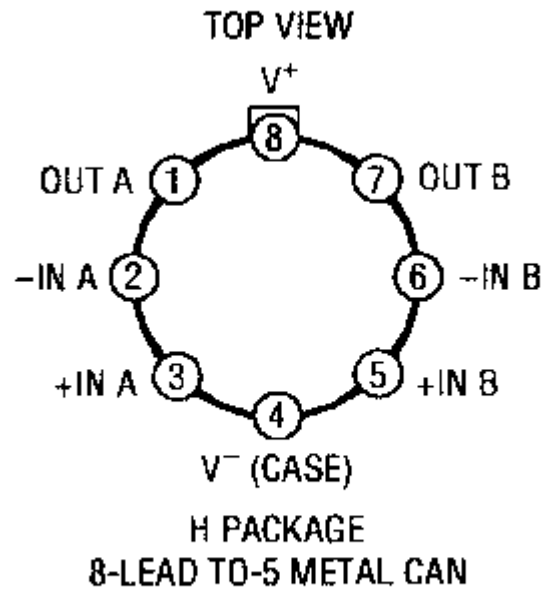

FIGURE 5

TABLE I DICE ELECTRICAL CHARACTERISTICS – Element Evaluation (Notes 1, 2) $V_S = \pm 15V$, $V_{CM} = 0V$, $T_A = 25^\circ C$ unless otherwise noted.

SYMBOL	PARAMETER	CONDITIONS	MIN	MAX	UNITS
V_{OS}	Input Offset Voltage			300	μV
		(Note 2)		450	μV
I_{OS}	Input Offset Current			10	nA
		(Note 2)		10	nA
I_B	Input Bias Current			30	nA
		(Note 2)		30	nA
A_{VOL}	Large-Signal Voltage Gain	$V_O = \pm 10V$, $R_L \geq 2k$	1.2		$V/\mu V$
		$V_O = \pm 10V$, $R_L \geq 600\Omega$	0.5		$V/\mu V$
	Input Voltage Range	(Note 1)	13.5		V
		(Notes 1, 2)	3.5		V
			0		V
CMRR	Common Mode Rejection Ratio	$V_{CM} = 13.5V, -15V$	97		dB
PSRR	Power Supply Rejection Ratio	$V_S = \pm 2V$ to $\pm 18V$	100		dB
	Channel Separation	$V_O = \pm 10V$, $R_L = 2k$	120		dB
V_{OUT}	Output Saturation Swing	$R_L \geq 2k$	± 12.5		V
		Output Low, No Load, (Note 2)		25	mV
		Output Low, 600Ω to GND, (Note 2)		10	mV
		Output Low, $I_{SINK} = 1mA$, (Note 2)		350	mV
		Output High, No Load, (Note 2)	4.0		V
Output High, 600Ω to GND, (Note 2)	3.4		V		
SR	Slew Rate		0.2		$V/\mu s$
I_S	Supply Current	Per Amplifier		0.55	mA
		(Note 2)		0.50	mA

Note 1: Guaranteed by design, characterization or correlation to other tested parameters.

Note 2: Specification applies for $V_{S+} = 5V$, $V_{S-} = 0V$, $V_{CM} = 0V$, $V_{OUT} = 1.4V$.

TABLE II ELECTRICAL CHARACTERISTICS – Post-Irradiation (Notes 1, 2)

$V_S = \pm 15V$, $V_{CM} = 0V$, $T_A = 25^\circ C$, unless otherwise noted.

SYMBOL	PARAMETER	CONDITIONS	NOTES	10KRAD(Si)		20KRAD(Si)		50KRAD(Si)		100KRAD(Si)		200KRAD(Si)		UNITS	
				MIN	MAX	MIN	MAX	MIN	MAX	MIN	MAX	MIN	MAX		
V_{OS}	Input Offset Voltage				450		450		600		750		900	μV	
			2		600		600		750		900			μV	
I_{OS}	Input Offset Current				10		10		15		20		25	nA	
			2		10		10		15		20			nA	
I_B	Input Bias Current				60		75		100		175		250	nA	
			2		80		100		125		200			nA	
	Input Voltage Range		1	13.5		13.5		13.5		13.5		13.5		V	
			1	-15.0		-15.0		-15.0		-15.0		-15.0		V	
			2	3.5		3.5		3.5		3.5				V	
			2	0		0		0		0				V	
CMRR	Common-Mode Rejection Ratio	$V_{CM} = 13V, -15V$		97		97		94		90		86		dB	
PSRR	Power Supply Rejection Ratio	$V_S = \pm 5V$ to $\pm 18V$		100		98		94		86		80		dB	
A_{VOL}	Large-Signal Voltage Gain	$R_L = 10k, V_O = \pm 10V$		500		200		100		50		25		V/mV	
V_{OUT}	Maximum Output Voltage Swing	$R_L = 10k$		± 12.5		± 12.5		± 12.5		± 12.5		± 12.5		V	
			2		25		30		40		50			mV	
			2		10		10		10		10				mV
			2		0.6		0.8		1.0		1.6				V
			2		4.0		4.0		4.0		4.0				V
			2		3.4		3.2		3.0		2.8				V
SR	Slew Rate	$R_L = 10k$		0.13		0.12		0.11		0.07		0.01		V/ μs	
I_S	Supply Current	Per Amplifier			0.55		0.55		0.55		0.55		0.55	mA	
			2		0.50		0.50		0.50		0.50			mA	

Note 1: Guaranteed by design, characterization, or correlation to other tested parameters..

Note 2: Specification applies for $V_S^+ = 5V$, $V_S^- = 0V$, $V_{CM} = 0V$, $V_{OUT} = 1.4V$.

TABLE III RH ELEMENT EVALUATION TABLE QUALIFICATION OF DICE SALE



RH CANNED SAMPLE TABLE FOR QUALIFYING DICE SALES

SUBGROUP	CLASS			OPERATION	MIL-STD-883		QUANTITY (ACCEPT NUMBER) REF. METHOD 2018 FOR S/S
	K/S	V	H/B		METHOD	CONDITION	
1	X	X		SEM	2018	N/A	100% REF. METHOD 2018 FOR S/S
2	X	X	X	ELEMENT ELECTRICAL (WAFER SORT @ 25°C)			100%
3	X	X	X	ELEMENT VISUAL (2nd OP)	2010	A	100%
4	X	X	X	INTERNAL VISUAL (3rd OP)	2010	A	ASSEMBLED PARTS ONLY
	X	X		DIE SHEAR MONITOR	2019		
5	X	X		BOND PULL MONITOR	2011		ASSEMBLED PARTS ONLY
	X	X		STABILIZATION BAKE	1008	C	
	X	X		TEMPERATURE CYCLE	1010	C	
	X	X		CONSTANT ACCELERATION	2001	E	
	X	X		FINE LEAK	1014	A	
6	X	X		GROSS LEAK	1014	C	45(0)
	X	X		FIRST ROOM ELECTRICAL - READ & RECORD (REPLACE ANY ASSEMBLY-RELATED REJECTS)			
	X	X		PRE BURN-IN ELECT. READ & RECORD @ +125°C or +150°C, -55°C			
	X	X		BURN-IN: +125°C/240 hrs. or +150°C/120 hrs.	1015	+ 125°C MINIMUM 240 HOURS	
	X	X		POST BURN-IN ELECT. READ & RECORD @ 25°C			
	X	X		POST BURN-IN ELECT. READ & RECORD @ +125°C or +150°C, -55°C			
7	X	X		TOTAL IRRADIATION DOSE	1019	A	15(0) OR 25(1) - # of wires
	X	X		PRE OP-LIFE ELECTRICAL @ 25°C READ & RECORD			
	X	X		OPERATING LIFE: +125°C/1000 hrs. or +150°C/500 hrs.	1005	+ 125°C MINIMUM 1000 HOURS	
	X	X		POST-OP-LIFE ELECT. (R & R @ 25°C, +125°C DR +150°C, -55°C)			
7	X	X	X	WIRE BOND EVALUATION	2011		

NOTE: LTC is not qualified to process to MIL-PRF-38534. This is an LTC imposed element evaluation that follows

MIL-STD-883 test methods and conditions. Please note the quantity and accept number from Sample Size Series of 5%, accept on O, and note that the actual sample and accept number does not begin until Subgroup 6 OP-LIFE.

NOTE: Tests within Subgroup 5 may be performed in any sequence.

NOTE: LTC's radiation tolerance (RH) die has a topside glassivation thickness of 4KA minimum.

NOTE: Sample sizes on the travelers may be larger than that indicated in the above table; however, the larger sample size is to accommodate extra units for replacement devices in the event of equipment or operator error and for assembly related rejects in Subgroup 6, and for Wire Bond Evaluation, Subgroup 7. The larger sample size is at all times kept segregated and, if used for qualification, has all the required processing imposed.