

Ultracompact LCD Backlight Inverters

A Svelte Beast Cuts High Voltage Down to Size

Jim Williams, Linear Technology Corporation

Jim Phillips, Gary Vaughn, CTS Wireless Components

INTRODUCTION

The liquid crystal display (LCD) has become ubiquitous. It is in use everywhere, from personal computers of all sizes to point-of-sale terminals as well as instruments, autos and medical apparatus. The LCD utilizes a cold cathode fluorescent lamp (CCFL) as a light source to back light the display. The CCFL requires a high voltage AC supply for operation. Typically, over 1000 volts RMS is required to initiate lamp operation, with sustaining voltages ranging from 200VAC to 800VAC. To date, the high voltage section of backlight "inverters" has been designed around magnetic transformers. A great deal of effort has been directed towards these ends, accompanied by a large volume of descriptive material.¹ Unfortunately, as available circuit board space continues to shrink, magnetic transformer based approaches begin to encounter difficulty. In particular, it is highly desirable to fashion laptop computers with large area screens, leaving little room for the backlight inverter board. In many cases there is so little space available that building the inverter function inside the LCD panel has become attractive, although to date impractical.

Limitations and Problems of Magnetic CCFL Transformers

Construction and high voltage breakdown characteristics of magnetic transformers present barriers to implementing them in these forthcoming space intensive designs. Additionally, as refined as magnetic technology is, other inverter problems associated with it also exist. Such problems include the necessity to optimize and calibrate the inverter for best performance with a given display type. Practically, this means that the manufacturer must, via either hardware or software, adjust inverter parameters to achieve optimum performance with a given display type. Changes in display choice must be accompanied by com-

mensurate adjustments in inverter characteristics. Another problem area is fail-safe protection due to self-destructive transformer malfunctions. Finally, the magnetic field provided by conventional transformers can interfere with operation of adjacent circuitry. With the exception of size, all of these problems are addressable, although incurring economic and circuit/system penalties.² What is really needed is high voltage generating capability that is inherently better suited to coming generations of backlight inverters. Piezoceramic transformers, an arcane and little known technology, has been tamed and made available for CCFL inverter use. This publication summarizes results of an extensive collaborative development effort between LTC and CTS Wireless Components (formerly Motorola Ceramic Products).

Piezoelectric Transformers

Piezoelectric Transformers (PZT), like magnetic devices, are basically energy converters. A magnetic transformer operates by converting an electrical input to magnetic energy and then reconverting the magnetic energy back to an electrical output. A PZT has an analogous operating mechanism. It converts an electrical input into *mechanical* energy and subsequently reconverts this mechanical energy back to an electrical output. The mechanical transport causes the PZT to vibrate, similar to quartz crystal operation, although at acoustic frequencies. The resonance associated with this acoustic activity is extraordinarily high; Q factors over 1000 are typical. This transformer action is accomplished by utilizing properties of certain

Note 1: See References 1 through 3 for examples.

Note 2: Again, see References 1 through 3.

 LTC and LT are registered trademarks of Linear Technology Corporation.

Piezoceramic inverter circuits and techniques are covered by LTC patents issued and pending. CTS Wireless Components (formerly Motorola Ceramic Products) patents, issued and pending, also apply.

Application Note 81

ceramic materials and structures. A PZT transformer's voltage gain is set by its physical configuration and the number of layers in its construction. This is obviously very different from a magnetic transformer, although some (very rough) magnetic analogs are turns ratio and core configuration. Also very different, and central to any serious drive scheme attempt, is that a PZT has a large input capacitance, as opposed to a magnetic transformer's input inductance.³

Figures 1 and 2 show PZTs; the surprisingly small size is readily apparent. The form factor is ideal for constructing space efficient CCFL backlight inverters. A complete, practical inverter appears in Figure 3.

Note 3: To call this description of PZT operation abbreviated is the kindest of verbiage. Those interested in piezoceramic theory, whether savant or scholar, will find tutorial in Appendices A and B. Appendix A is a brief treatment; B is considerably more detailed. Both sections were written by Jim Phillips of CTS Wireless Components.



Figure 1. Piezoceramic Transformers Compared to a Dime for Size. 1.5 Watt (Photo Upper) and 10 Watt (Photo Lower) Units Are Shown. Devices Are Narrower Than Magnetic Transformers

AN81 F01.tif

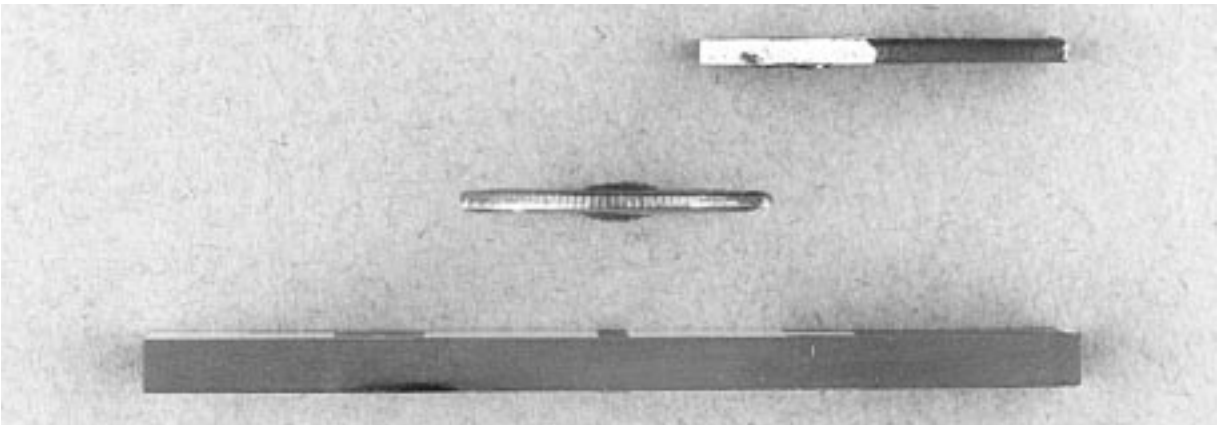

Figure 2. Figure 1's Piezoceramic Transformers Rotated to Show Height. Dime Is Photo Center. Height Is Smaller Than Magnetic Types

AN81 F02.tif

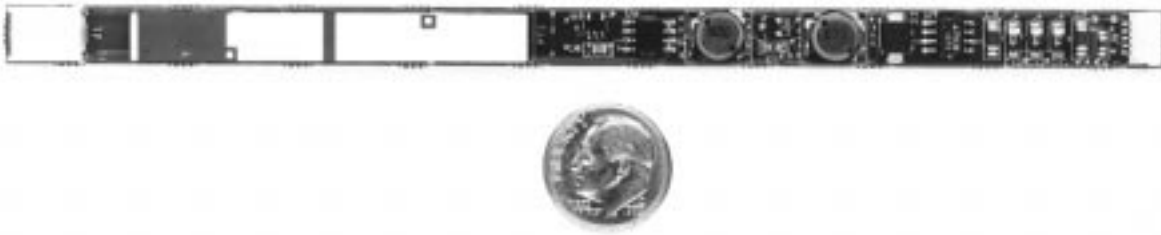

Figure 3. Complete LCD Backlight Inverter Compared to Dime for Size. Piezoceramic Transformer (Photo Left) Permits Significantly Thinner Board Size

Piezoelectric transformer technology is not new. It has been employed before, in various forms.⁴ More familiar examples of piezoelectrics are barbecue grill ignitors (direct mechanical input to the PZT produces an electrical discharge) and marine sonar transducers (electrical input produces a pronounced sonic output). Piezoelectrics are also used in speakers (tweeters), medical ultrasound transducers, mechanical actuators and fans. Piezoelectric based backlight inverters have been attempted, but previous transformer and circuit approaches could not provide power, efficiency and wide dynamic range of operation. Transformer operating regions were restricted, with complex and ill-performing electronic control schemes. Additionally, the PZT mounting schemes employed enlarged size, negating the PZT's size advantage.

Developing a PZT Transformer Control Scheme

It is instructive to review the path to a practical circuit. Figure 4 treats the PZT like a quartz crystal, placing it in a Pierce type oscillator.⁵ Self-resonance occurs and a sinusoidal AC high voltage drives the lamp. This circuit has a number of unpleasant features. Very little power is available, due to the circuit's high output impedance. Additionally, the PZT has a number of other spurious modes besides its desired 60kHz fundamental. Changes in drive level or load characteristics induce "mode-hopping," manifested by PZT resonance jumping to subharmonics or harmonics. Sometimes, several modes occur simultaneously! Operation in these modes is characterized by low efficiency and instability. Practically, this circuit was never intended as a serious candidate, only an exploratory exercise. Its contribution is demonstrating that PZT self-resonance is a potentially viable path. Figure 5, a feedback oscillator, addresses the high output impedance problem with a totem style pair. This is partially successful, al-

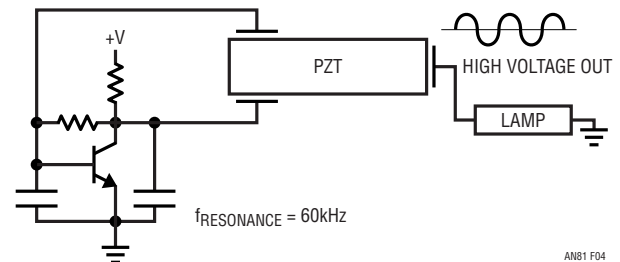

Figure 4. Pierce Type Circuit Sustains Resonance, But Cannot Deliver Power Efficiently. Circuit Also "Mode-Hops" Due to Transformer's Parasitic Resonances

though efficient totem drive devoid of simultaneous conduction requires care. Mode-hopping persists, in this case aggravated by the long acoustic transit time through the PZT and the wideband feedback. The sonic transit time produces enormous feedback phase error. Even worse, this phase error varies with line and load conditions. The alternate feedback scheme shown senses current, as opposed to voltage. This eliminates the voltage divider induced loading but does nothing to address the phase uncertainties and mode-hopping. A final problem, common to all resonant oscillators, concerns start-up. Gentle tapping of the PZT will usually start a reticent circuit but this is hardly reassuring.⁶ Figure 6 is similar but uses a ground-referred push-pull power stage, simplifying the drive scheme. This is a better approach but phase, mode-hopping and start-up problems are as before.

Figure 7 retains the drive scheme and solves the remaining problems. Central to circuit operation is a new transformer terminal labeled "feedback." This connection, precisely positioned on the transformer, provides constant-phase resonance information regardless of operating conditions.

Note 4: For examples, see References 4 through 11.

Note 5: See References 12 through 14.

Note 6: At the low voltage end, please!

Application Note 81

When power is applied, the RC oscillator drives Q1 and Q2 at a frequency outside resonance. The PZT, excited off-resonance, at first responds very inefficiently, although voltage-amplified resonant waveforms appear at the feedback and output terminals. The resonant information present at the feedback terminal injection-locks the RC oscillator, pulling it to the PZT's resonance. Now, the PZT is supplied with on-resonance drive and efficient operation commences.⁷ The feedback terminal's constant-phase characteristic is maintained over all line and load conditions, and the loop enforces resonance.

Figure 8, retaining the resonance loop, adds an amplitude control loop to stabilize lamp intensity. Lamp current is sensed and fed back to a voltage regulator to control PZT drive power. The regulator's reference point is variable, permitting lamp intensity to be set at any desired level. The amplitude and resonance loops operate simultaneously, although fully independent of each other. This two loop operation is the key to high power, wide range, reliable control.

Figure 9 is a detailed schematic of Figure 8's concept. The resonance loop is comprised of Q4 and the CMOS inverter based oscillator. The amplitude loop centers around the LT1375 switching regulator. Figure 10 shows waveforms. Traces A and B are Q2 and Q1 gate drives, respectively. Resultant Q1 and Q2 drain responses are traces C and D. The LT1375 step-down switching regulator, responding to the rectified and averaged lamp current, closes the amplitude loop by driving the L1-L2 junction (trace E). The 4.7 μ F capacitor at the V_C pin stabilizes the loop.⁸ Note that no filtering is used—the raw LT1375 500kHz PWM output directly drives the L1-L2-PZT network. This is permissible because the PZT Q factor is so high that it responds only at resonance (again, see traces C and D).

Note 7: This is the heart and soul of a bootstrapped start-up.

Note 8: This is a deceptively innocent sentence. The PZT's acoustic transport speed furnishes an almost pure delay in the loop, making compensation an interesting exercise. See Appendix C, "A Really Interesting Feedback Loop."

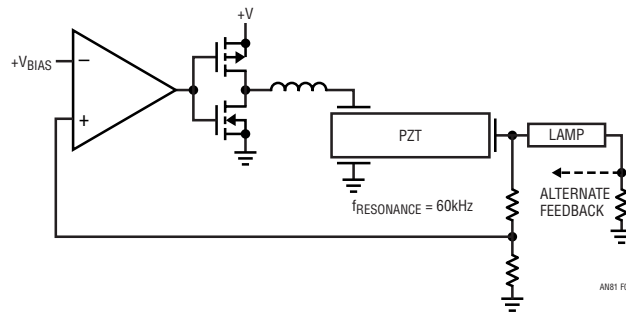

Figure 5. Feedback Based Oscillator Has More Efficient Drive Stage. Poorly Defined Transformer Phase Characteristics Cause Spurious Modes with Line and Load Variations

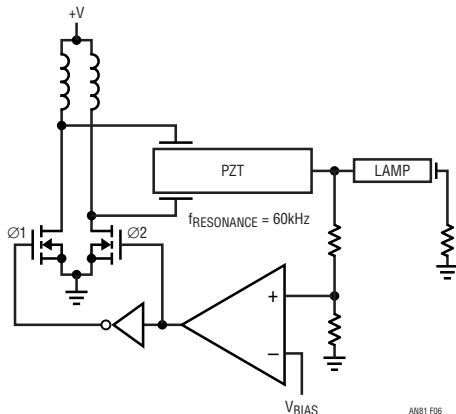

Figure 6. Push-Pull Version of Figure 5 Retains Efficiency While Permitting Simple All N-Channel Drive. Poor Phase Characteristics Still Preclude Stable Loop Operation

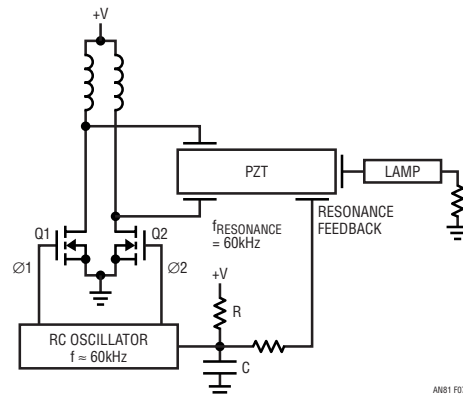

Figure 7. Feedback Tap On Transformer Synchronizes RC Oscillator, Providing Stable Phase Characteristics. Loop Maintains Fundamental Resonance Under All Conditions

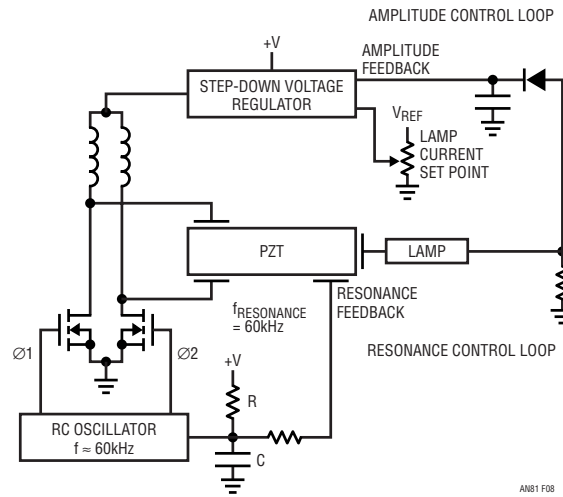

Figure 8. Previous Circuit with Amplitude Control Loop Added. New Circuitry Senses Lamp Current, Accordingly Controls PZT Drive Power. Resonance and Amplitude Control Loops Do Not Interact

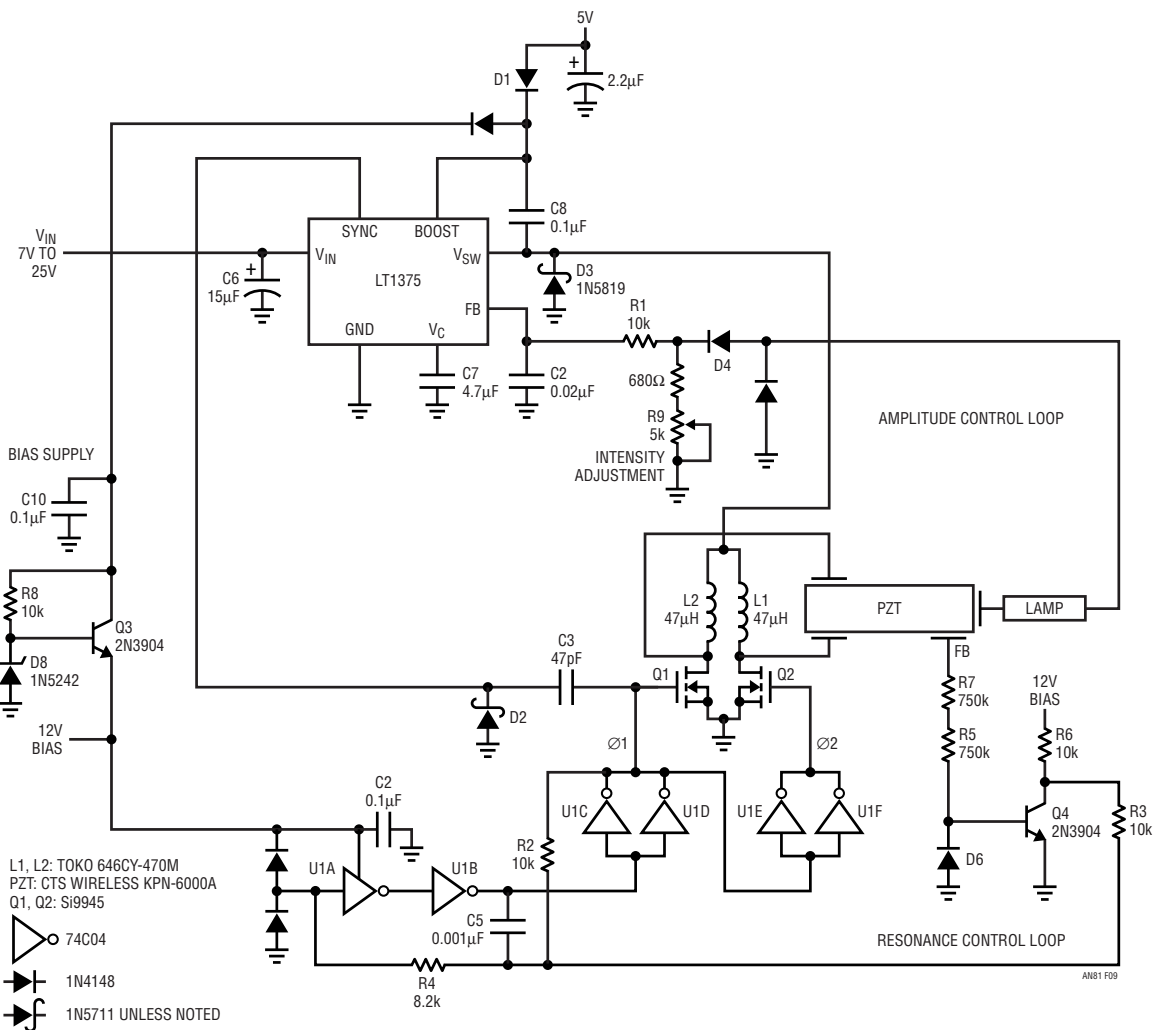

Figure 9. Complete Piezoceramic Transformer (PZT) Based Backlight Inverter. PZT's Resonant Feedback Synchronizes Inverter Based RC Oscillator Via Q4. Amplitude Control Loop Powers PZT Via LT1375 Switching Regulator

Application Note 81

The feedback tap (trace F), supplying phase coherent information, looks like a current source to Q4 under all conditions (note trace F's vertical scale factor). The 750k resistors in series minimize parasitic capacitance at the transformer feedback terminal. Q4's collector (trace G) clamps this information to a lower voltage and injection-locks the CMOS inverter based oscillator, closing the resonance loop. The oscillator insures start-up (refer to text associated with Figure 7) and effectively filters the already narrow band resonant feedback, further insuring resonance loop fidelity under all conditions. Trace H is the PZT's high voltage output delivered to the lamp.

In this example dimming is set with a potentiometer, although simple current summing to the LT1375 feedback pin allows electronic control.⁹

Additional Considerations and Benefits

As previously mentioned, the PZT has other benefits besides small size. One of these is safety. A PZT cannot fail due to output shorts or opens. Short circuits knock the PZT off-resonance and it simply stops, absorbing no energy. Open circuits do not cause arc-induced PZT failures because the PZT cannot "arc turns" like a magnetic transformer. However, it is always wise to sense and arrest an overvoltage condition. The PZT is capable of large outputs, despite its small size. Powered by a 10 volt supply, it can easily produce 3000V_{RMS} if uncontrolled. This mandates some form of overvoltage protection in a

Note 9: See Reference 1 for information on various dimming control schemes.

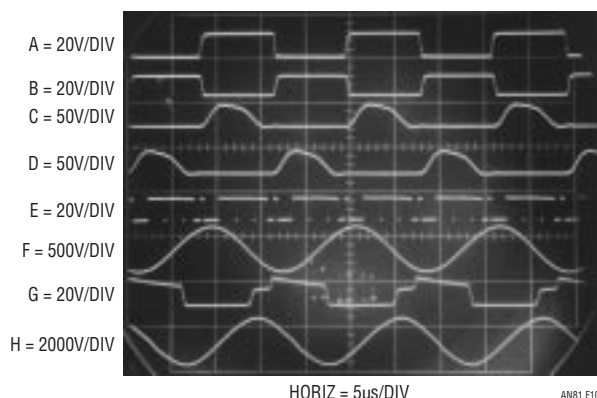

Figure 10. Waveforms for Figure 9. Traces A and B Are Q2 and Q1 Drive, Respectively. Resultant Q1 and Q2 Drain Responses Are Traces C and D. LT1375 V_{SW} Output Is Trace E. PZT Resonance Tap Is Trace F; Q4's Collector, Trace G. PZT High Voltage Output Is Trace H. PZT Acts As a Mechanical Filter, Producing Low Distortion Sine Waves

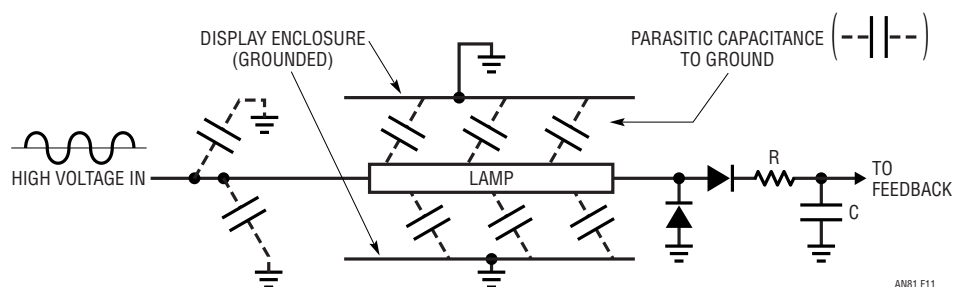

Figure 11. Parasitic Capacitance Absorbs Energy and Corrupts Drive Waveform Due to Finite Source Impedance vs Frequency in Magnetic Based Inverters. Differing Amounts of Capacitance with Various Displays Cause RC Averaging Errors, Necessitating Calibration for Each Display Type. PZT's Highly Resonant Characteristics Eliminate Calibration Requirement

production circuit. Another significant attribute is that amplitude control loop scale factor is almost completely independent of load, including parasitic capacitance. The practical advantage is that a wide range of displays may be used with no recalibration of any kind. This is in direct opposition to magnetically based inverters which require some form (either hardware or software based) of scale factor recalibration when displays are changed. Understanding why this is so requires some study.

Display Parasitic Capacitance and Its Effects

Almost all displays introduce some amount of parasitic capacitance between the lamp, its leads and electrically conductive elements within the display. Such elements may include the display enclosure, the lamp reflector or both. Figure 11 diagrams this situation. The parasitic capacitance to ground has two major impacts. It absorbs energy, causing lost power. This raises overall inverter input power because the inverter must supply both parasitic and intended load paths. Some techniques can minimize the effects of parasitic capacitance loss paths but they cannot be completely compensated.¹⁰

A second effect of parasitic capacitance, manifested in magnetically based inverters, is much more subtle. Magnetically based inverters have finite source impedance at frequency, corrupting the produced sinusoid. The amount of parasitic capacitance influences the degree of corruption. Different displays have varying amounts of parasitic capacitance, resulting in varying degrees of waveform distortion with different displays. The RC averaging time constant is *not* an RMS to DC converter and produces different outputs as distortion content in its input wave-

form changes. The amplitude loop acts on the DC output of the RC averager and the assumption is that the input waveform distortion content is constant. In a well designed magnetically based inverter this is essentially true, even as operating conditions vary. The averager's output error is consistent and can be "calibrated away" by scale factor adjustments. However, if the display type is changed, the averager is subjected to a differently distorted waveform and scale factor adjustments are required. This necessitates some form of calibration constant adjustment for each display type, complicating production and inventory requirements. PZT based inverters are largely immune to this problem because of their extraordinarily high Q factor, typically over 1000. The PZT forces the output waveform to have a consistent amount of distortion, nominally zero. The PZT's resonant mechanical filtering produces an almost pure sinusoidal output, even with widely varying parasitic and intended loads. Figure 12 shows PZT output voltage (trace A) and current (trace B) with a low parasitic loss display. Waveshapes are essentially ideal sinusoids. In Figure 13 a display with much higher parasitic losses has been substituted. Minor waveform distortion, particularly in the current trace (B), is evident, although minimal. The RC averager produces little error vs Figure 12 and less than 0.5% lamp current difference occurs between the two cases. In contrast, a magnetically based inverter can easily suffer 10% to 15% lamp current differences, impacting display luminosity and/or lamp lifetime.

Note 10: Complete treatment of this issue is sacrificed here to maintain focus. A more thorough investigation appears in Reference 1.

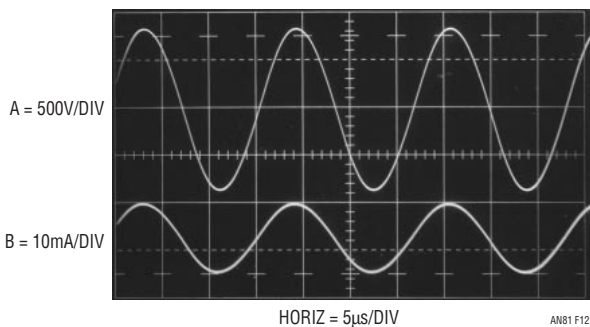

Figure 12. PZT Inverter Driving a Low Parasitic Capacitance Display. Trace A Is Lamp Voltage, Trace B Lamp Current. Waveforms Are Nearly Ideal Sinusoids

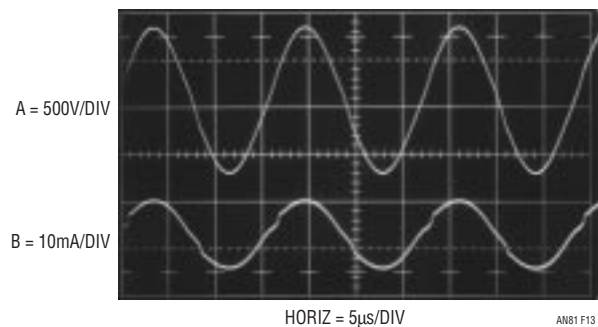

Figure 13. Display with Higher Capacitive Loss Causes Minor Distortion. Lamp RMS Current Varies Only 0.5% vs Figure 12.

Application Note 81

REFERENCES

1. Williams, J., "A Fourth Generation of LCD Backlight Technology," Linear Technology Corporation, Application Note 65, November 1995.
2. Williams, J., "Techniques for 92% Efficient LCD Illumination," Linear Technology Corporation, Application Note 55, August 1993.
3. Williams, J., "Illumination Circuitry for Liquid Crystal Displays," Linear Technology Corporation, Application Note 49, August 1992.
4. Rosen, C. A., "Ceramic Transformers and Filters," Proc. Electronic Components Symposium, 1956, pp. 205–211.
5. Mason, W. P., "Electromagnetic Transducers and Wave Filters," D. Van Nostrand Company, Inc., 1948.
6. Ohnishi, O., Kishie, H., Iwamoto, A., Sasaki, Y., Zaitzu, T., Inoue, T., "Piezoelectric Ceramic Transformer Operating in Thickness Extensional Vibration Mode for Power Supply," Ultrasonic Symposium Proc., 1992, pp. 483–488.
7. Zaitzu, T., Ohnishi, O., Inoue, T., Shoyama, M., Ninomiya, T., Hua, G., Lee, F. C., "Piezoelectric Transformer Operating in Thickness Extensional Vibration and Its Application to Switching Converter," PESC '94 Record, June 1994, pp. 585–589.
8. Zaitzu, T., Shigehisa, T., Inoue, T., Shoyama, M., Ninomiya, T., "Piezoelectric Transformer Converter with Frequency Control," INTELEC '95, October 1995.
9. Williams, J., "Piezoceramics Plus Fiber Optics Boost Isolation Voltages," *EDN*, June 24, 1981.
10. Williams, J., Huffman, B., "DC-DC Converters, Part III. Design DC-DC Converters for Power Conservation and Efficiency," "Ceramic Power Converter," *EDN*, November 10, 1988, pp. 209–224, pp. 222–224.
11. Williams, J., Huffman, B., "Some Thoughts On DC-DC Converters," "20,000V Breakdown Converter," Linear Technology Corporation, Application Note 29, October 1988, pp. 27–28.
12. Mattheys, R. L., "Crystal Oscillator Circuits," Wiley, New York, 1983.
13. Frerking, M. E., "Crystal Oscillator Design and Temperature Compensation," Van Nostrand Reinhold, New York, 1978.
14. Williams, J., "Circuit Techniques for Clock Sources," Linear Technology Corporation, Application Note 12, October 1985.

APPENDIX A

PIEZOELECTRIC TRANSFORMERS “Good Vibrations”

James R. Phillips

Sr. Member of Technical Staff

CTS Wireless Components

4800 Alameda Blvd. N.E.

Albuquerque, New Mexico 87113

(505) 348-4286

Jim.Phillips@CTSWireless1.com

Piezoelectric transformers are, in fact, not transformers. There are no wires or magnetic fields. A better analogy would actually be that of a dynamo. The piezoelectric “transformer” works exactly like a motor mechanically coupled to a generator. In order to understand this concept, one must start by understanding the basics of piezoelectricity.

Piezowhat?

Many materials exhibit some form of piezoelectric effect. The ones most commonly used are Quartz, Lithium Niobate, and PZT or Lead Zirconate Titanate with the transformer using the latter. There are two piezoelectric effects, the direct effect and the inverse effect. In the case of the direct effect, placing a force or vibration (*stress*) on the piezoelectric element will result in the generation of a charge. (Figure A1) The polarity of this charge depends upon the orientation of the stress when compared to the direction of polarization in the piezoelectric element. The polarization direction, for PZT, is set by poling or applying a high D.C. field in the range of 45KV/cm to the element during the manufacturing process.

The inverse piezoelectric effect is, as the name implies, the opposite of the direct effect. (Figure 2) Applying an electric field (voltage) to the piezoelectric element results in a dimensional change. (*strain*) The direction of the change is likewise linked to the polarization direction. Fields applied at the same polarity of the element result in a

dimensional increase, while those of opposite polarity result in a decrease. It should be noted that an increase in one dimension in a structure would result in a decrease in the other two through Poisson’s coupling. This phenomenon is an important factor in the operation of the transformer.

The piezoelectric transformer uses both the direct and inverse effects in concert to create high voltage step-up ratios. (Figure 3) The input portion of the transformer is driven by a sine wave voltage, which causes it to vibrate. (*inverse effect-motor*) The vibration is coupled through the structure to the output, which results in the generation of an output voltage. (*direct effect-generator*)

Alchemy and Black Magic

The piezoelectric transformer is constructed of PZT ceramic, but more exactly, a multilayer ceramic. The manufacture of the transformer is similar to the manufacture of ceramic chip capacitors. Layers of flexible, unfired PZT ceramic tape are printed with metallic patterns and then aligned and stacked to form the required structure. The stacks are then pressed, diced and fired to create the final ceramic device.

The input section of the transformer has, in fact, a multilayer ceramic capacitor structure. (Figure 4) The metal electrodes are patterned in such a way as to create an interdigitated plate configuration. (*section A-A*) The output section of the transformer has no electrode plates between the ceramic layers and, as a result, fires into a single ceramic structure. The end of the output section is coated with a conductive material, which forms the output electrode for the transformer.

The next step in the construction is to establish the polarization directions in the two halves of the transformer. The input section of the transformer is poled across the inter-digitated electrodes resulting in a polarization direction aligned vertically to the thickness. The output section is poled to create a horizontal or length oriented polarization direction. During operation, the input is driven in thickness mode. This means that a voltage is applied between the parallel plates of the input causing it to become thicker and thinner on alternate halves of the

Application Note 81

sine wave. The change in input thickness couples through to the output section causing it to become longer and shorter, generating the output voltage. The resulting voltage step-up ratio is then proportional to the ratio of the output length, which generates the voltage, to the thickness of the input layers, across which the drive voltage is applied.

The Fun Part

The equivalent circuit model for the piezoelectric transformer outwardly looks identical to that of its series resonant magnetic counterpart. (Figure 5) The differences, however, extend past the nominal values to what the various components represent. The input and output capacitance are simply the result of having a dielectric between two metal plates. The effective dielectric constant of PZT runs between 400 and 5,000, depending upon composition. This, unfortunately, is where basic electronics end. The rest of the components are more complicated. The inductance, L_M , is actually the mass of the transformer. The capacitance, C_M , is the compliance of the material or the inverse of spring rate. The compliance is calculated from the applicable generalized beam equation and the Young's modulus. The resistor, R_M , represents the combination of dielectric loss and the mechanical Q of the transformer. It is already obvious to most that truly understanding this device requires background in electronics, mechanics and materials, but we're not quite done yet.

The resonant frequency is related to the product of the capacitance, C_M and inductance, L_M . This, however, represents the acoustic, not electrical, resonate frequency. The transformer is designed to operate in length resonance. The associated motions are identical to that of a vibrating string. The major difference is that the frequencies are in the ultrasonic range and vary, by design, between 50kHz and 2MHz. Like the string, the transformer has displacement nodes and anti-nodes. Mechanically clamping a node will prevent vibration. This will reduce

efficiency in the best case and prevent operation in the worst. Mounting the transformer is crucial. It can not be simply reflowed to a PCB.

The final element in the model is the "ideal" transformer with ratio N. This transformer actually represents three separate transformations. The first is the transformation of electrical energy into mechanical vibration. This is a function of the piezoelectric constant, which is electric field divided by stress, the stress area and the electric field length. The second transformation is the transfer of the mechanical energy from the input section to the output section and is a function of the Poisson's ratio for the material. The final transformation is the transfer of mechanical energy back into electrical energy. This is calculated in a similar fashion to the input side.

A Resonant Personality

Resonant magnetic high voltage transformers have an electrical Q of between 20 and 30. The equivalent for the piezoelectric transformer is its mechanical Q, which approaches 1,000. This is both good and bad. The ultimate efficiency can be higher, but the usable bandwidth of the transformer is only 2.5% of that of the magnetic. In addition, as shown earlier, the resonant frequency is dependent upon the compliance of the material, which, in turn, is a function of the Young's modulus. Piezoelectric materials have the unusual effect that Young's modulus changes with electrical load. In most, if not all, cases, the shift in resonant frequency over rated load is greater than the usable bandwidth. (Figure 6) The piezoelectric transformer must be run at resonance to maintain efficiency and stability. The near-resonance designs used with magnetic transformers work poorly, if at all with piezoelectrics. Tracking oscillators are a requirement.

Rosen¹ first proposed the concept of the piezoelectric transformer in 1956. It is now evident why it took 43 years to get it right.

Note 1: See Reference 4.

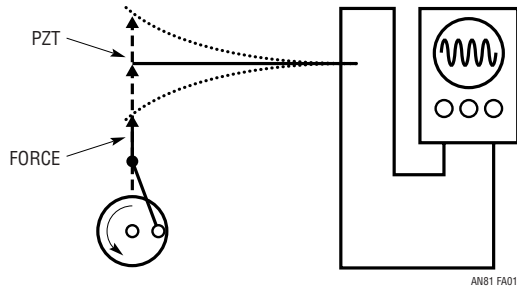

Figure 1. Direct Piezoelectric Effect: Force or Vibration Results in Output Voltage

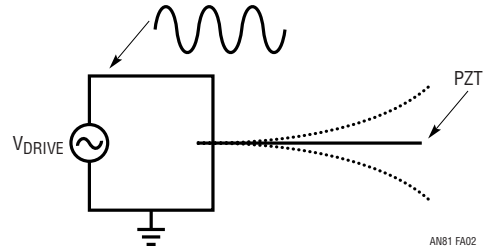

Figure 2. Inverse Piezoelectric Effect: Applied Voltage Results in Vibration or Movement

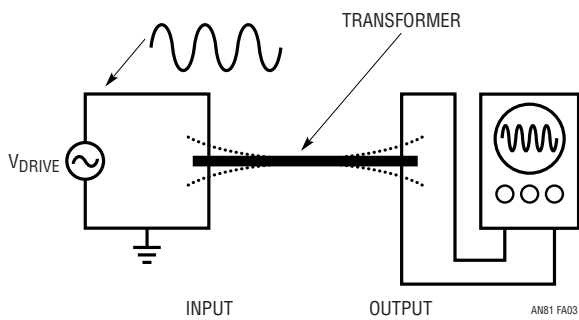

Figure 3. Transformer: Applied Voltage Results in Vibration Which Causes Output Voltage

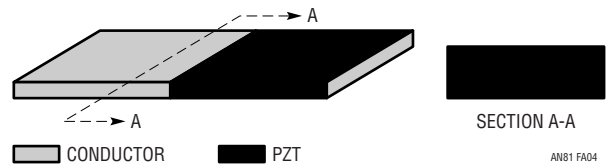

Figure 4. Piezoelectric Transformer: Multilayer PZT Construction

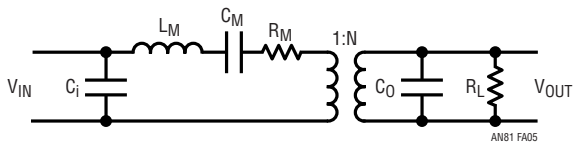

Figure 5. Piezoelectric Transformer: Equivalent Circuit Model

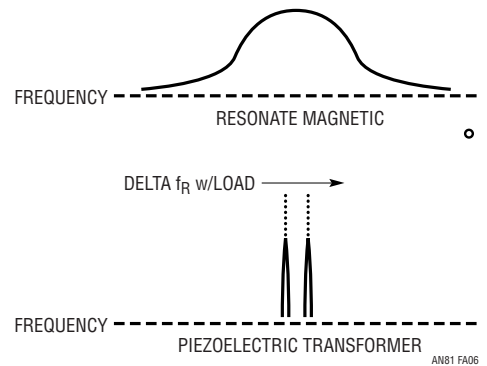

Figure 6. Transformer Bandwidth Comparison: Magnetic vs Piezoelectric

Application Note 81

APPENDIX B

PIEZOELECTRIC TECHNOLOGY PRIMER

James R. Phillips

Sr. Member of Technical Staff

CTS Wireless Components

4800 Alameda Blvd. N.E.

Albuquerque, New Mexico 87113

(505) 348-4286

Jim.Phillips@CTSWireless1.com

Piezoelectricity

The piezoelectric effect is a property that exists in many materials. The name is made up of two parts; piezo, which is derived from the Greek word for pressure, and electric from electricity. The rough translation is, therefore, pressure- electric effect. In a piezoelectric material, the application of a force or stress results in the development of a charge in the material. This is known as the direct piezoelectric effect. Conversely, the application of a charge to the same material will result in a change in mechanical dimensions or strain. This is known as the indirect piezoelectric effect.

Several ceramic materials have been described as exhibiting a piezoelectric effect. These include lead-zirconate-titanate (PZT), lead-titanate (PbTiO_2), lead-zirconate (PbZrO_3), and barium-titanate (BaTiO_3). These ceramics are not actually piezoelectric but rather exhibit a polarized electrostrictive effect. A material must be formed as a single crystal to be truly piezoelectric. Ceramic is a multi crystalline structure made up of large numbers of randomly orientated crystal grains. The random orientation of the grains results in a net cancelation of the effect. The ceramic must be polarized to align a majority of the individual grain effects. The term piezoelectric has become interchangeable with polarized electrostrictive effect in most literature.

Piezoelectric Effect

It is best to start with an understanding of common dielectric materials in order to understand the piezoelectric effect. The defining equations for high permittivity dielectrics are:

$$C = \frac{K\epsilon_r A}{t} = \frac{\epsilon_0 \epsilon_r A}{t} = \frac{\epsilon A}{t} \quad \text{and} \quad Q = CV \rightarrow Q = \frac{\epsilon AV}{t}$$

where:

C = Capacitance

A = Capacitor plate area

ϵ_r = Relative dielectric constant

ϵ_0 = Dielectric constant of air
= 8.85×10^{-12} farads/meter

ϵ = Dielectric constant

V = Voltage

t = Thickness or plate separation

Q = Charge

In addition, we can define electric displacement, D, as charge density or the ratio of charge to the area of the capacitor:

$$D = \frac{Q}{A} = \frac{\epsilon V}{t}$$

and further define the electric field as:

$$E = \frac{V}{t} \quad \text{or} \quad D = \epsilon E$$

These equations are true for all isotropic dielectrics. Piezoelectric ceramic materials are isotropic in the unpolarized state, but they become anisotropic in the poled state. In anisotropic materials, both the electric field and electric displacement must be represented as vectors with three dimensions in a fashion similar to the mechanical force vector. This is a direct result of the dependency of the

ratio of dielectric displacement, D , to electric field, E , upon the orientation of the capacitor plate to the crystal (or poled ceramic) axes. This means that the general equation for electric displacement can be written as a state variable equation:

$$D_i = \epsilon_{ij}E_j$$

The electric displacement is always parallel to the electric field, thus each electric displacement vector, D_i , is equal to the sum of the field vector, E_j , multiplied by its corresponding dielectric constant, ϵ_{ij} :

$$\begin{aligned} D_1 &= \epsilon_{11}E_1 + \epsilon_{12}E_2 + \epsilon_{13}E_3 \\ D_2 &= \epsilon_{21}E_1 + \epsilon_{22}E_2 + \epsilon_{23}E_3 \\ D_3 &= \epsilon_{31}E_1 + \epsilon_{32}E_2 + \epsilon_{33}E_3 \end{aligned}$$

Fortunately, the majority of the dielectric constants for piezoelectric ceramics (as opposed to single crystal piezoelectric materials) are zero. The only non-zero terms are:

$$\epsilon_{11} = \epsilon_{22}, \epsilon_{33}$$

Axis Nomenclature

The piezoelectric effect, as stated previously, relates mechanical effects to electrical effects. These effects, as shown above, are highly dependent upon their orientation to the poled axis. It is, therefore, essential to maintain a constant axis numbering scheme (Figure B1).

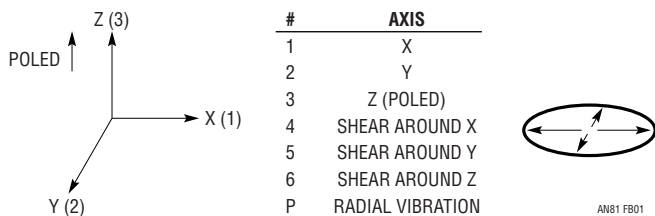

Figure B1

For electro-mechanical constants:

$$d_{ab}, a = \text{Electrical direction}; b = \text{Mechanical direction}$$

Electrical-Mechanical Analogies

Piezoelectric devices work as both electrical and mechanical elements. There are several electrical-mechanical analogies that are used in designing modeling the devices.

ELECTRICAL UNIT		MECHANICAL UNIT	
e	Voltage (Volts)	f	Force (Newtons)
i	Current (Amps)	v	Velocity (Meter/Second)
Q	Charge (Coulombs)	s	Displacement (Meters)
C	Capacitance (Farads)	C_M	Compliance (Meters/Newton)
L	Inductance (Henrys)	M	Mass (Kg)
Z	Impedance	Z_M	Mechanical Impedance

$$i = \frac{dQ}{dt}$$

$$v = \frac{ds}{dt}$$

$$e = L \frac{di}{dt} = L \frac{d^2Q}{dt^2}$$

$$f = M \frac{dv}{dt} = M \frac{d^2s}{dt^2}$$

Coupling

Coupling is a key constant used to evaluate the “quality” of an electro-mechanical material. This constant represents the efficiency of energy conversion from electrical to mechanical or mechanical to electrical.

$$k^2 = \frac{\text{Mechanical Energy Covered to Electrical Charge}}{\text{Mechanical Energy Input}}$$

or

$$k^2 = \frac{\text{Mechanical Energy Covered to Mechanical Displacement}}{\text{Electrical Energy Input}}$$

Electrical, Mechanical Property Changes with Load

Piezoelectric materials exhibit the somewhat unique effect that the dielectric constant varies with mechanical load and the Young’s modulus varies with electrical load.

Dielectric Constant:

$$\epsilon_r \text{ FREE } (1 - k^2) = \epsilon_r \text{ CLAMPED}$$

This means that the dielectric “constant” of the material reduces with mechanical load. Here “Free” stands for a state when the material is able to change dimensions with

Application Note 81

applied field. “Clamped” refers to either a condition where the material is physically clamped or is driven at a frequency high enough above mechanical resonance that the device can’t respond to the changing E field.

Elastic Modulus (Young’s Modules):

$$Y_{\text{OPEN}} (1 - k^2) = Y_{\text{SHORT}}$$

This means that the mechanical “stiffness” of the material reduces when the output is electrically shorted. This is important in that both the mechanical Q_M and resonate frequency will change with load. This is also the property that is used in the variable dampening applications.

Elasticity

All materials, regardless of their relative hardness, follow the fundamental law of elasticity (Figure B2). The elastic properties of the piezoelectric material control how well it will work in a particular application. The first concepts, which need to be defined, are stress and strain.

For any given bar of any material:

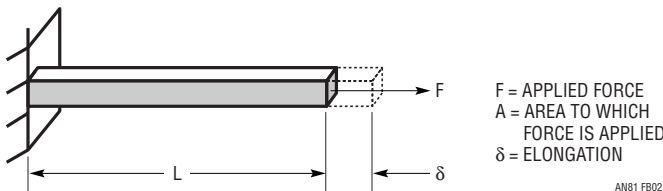

Figure B2

$$\text{Stress} = \sigma = F/A$$

$$\text{Strain} = \lambda = \delta/L$$

The relationship between stress and strain is Hooke’s Law which states that, within the elastic limits of the material, strain is proportional to stress.

$$\lambda = S\sigma$$

or, for an anisotropic material

$$\lambda_i = S_{ij}\sigma_j$$

Note: The constant relating stress and strain is the modulus of elasticity or Young’s modulus and is often represented by S, E or Y.

Piezoelectric Equation

It has been previously shown that when a voltage is applied across a capacitor made of normal dielectric material, a charge results on the plates or electrodes of the capacitor. Charge can also be produced on the electrodes of a capacitor made of a piezoelectric material by the application of stress. This is known as the Direct Piezoelectric Effect. Conversely, the application of a field to the material will result in strain. This is known as the Inverse Piezoelectric Effect. The equation, which defines this relationship, is the piezoelectric equation.

$$D_i = d_{ij}\sigma_j$$

where:

$D_i \equiv$ Electrical displacement (or charge density)

$d_{ij} \equiv$ Piezoelectric modulus, the ratio of strain to applied field or charge density to applied mechanical stress

Stated differently, d measures charge caused by a given force or deflection caused by a given voltage. We can, therefore, also use this to define the piezoelectric equation in terms of field and strain.

$$D_i = \frac{\sigma_j \lambda_i}{E_j}$$

Earlier, electric displacement was defined as

$$D_i = \epsilon_{ij} E_j$$

therefore,

$$\epsilon_{ij} E_j = d_{ij}\sigma$$

and

$$E_j = \frac{d_{ij}\sigma_j}{\epsilon_{ij}}$$

which results in a new constant

$$g_{ij} = \frac{d_{ij}}{\epsilon_{ij}}$$

This constant is known as the piezoelectric constant and is equal to the open circuit field developed per unit of applied stress or as the strain developed per unit of applied charge density or electric displacement. The constant can then be written as:

$$g = \frac{\text{field}}{\text{stress}} = \frac{\text{volts / meter}}{\text{newtons / meter}^2} = \frac{\Delta L / L}{\epsilon V / t}$$

Fortunately, many of the constants in the formulas above are equal to zero for PZT piezoelectric ceramics. The non-zero constants are:

$$s_{11} = s_{22}, s_{33}, s_{12}, s_{13} = s_{23}, s_{44}, s_{66} = 2(s_{11} - s_{12})$$

$$d_{31} = d_{32}, d_{33}, d_{15} = d_{24}$$

Basic Piezoelectric Modes

See Figure B3

Poling

Piezoelectric ceramic materials, as stated earlier, are not piezoelectric until the random ferroelectric domains are aligned. This alignment is accomplished through a process known as “poling”. Poling consists of inducing a D.C. voltage across the material. The ferroelectric domains align to the induced field resulting in a net piezoelectric effect. It should be noted that not all the domains become exactly aligned. Some of the domains only partially align and some do not align at all. The number of domains that align depends upon the poling voltage, temperature, and the time the voltage is held on the material. During poling the material permanently increases in dimension between the poling electrodes and decreases in dimensions parallel to the electrodes. The material can be de-poled by reversing the poling voltage, increasing the temperature beyond the materials Currie point, or by inducing a large mechanical stress.

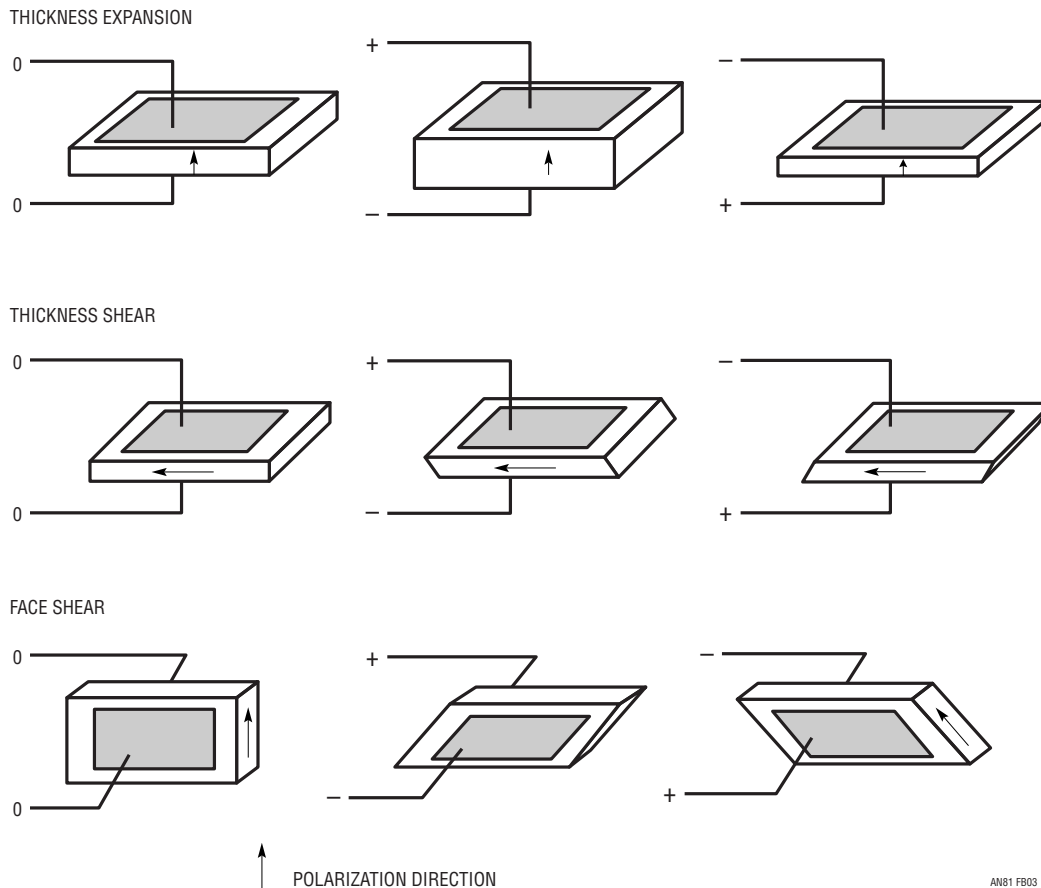

Figure B3

Application Note 81

Post Poling

Applied Voltage:

Voltage applied to the electrodes at the same polarity as the original poling voltage results in a further increase in dimension between the electrodes and decreases the dimensions parallel to the electrodes. Applying a voltage to the electrodes in an opposite direction decreases the dimension between the electrodes and increases the dimensions parallel to the electrodes.

Applied Force:

Applying a compressive force in the direction of poling (perpendicular to the poling electrodes) or a tensile force parallel to the poling direction results in a voltage generated on the electrodes which has the same polarity as the original poling voltage. A tensile force applied perpendicular to the electrodes or a compressive force applied parallel to the electrodes results in a voltage of opposite polarity.

Shear:

Removing the poling electrodes and applying a field perpendicular to the poling direction on a new set of electrodes will result in mechanical shear. Physically shearing the ceramic will produce a voltage on the new electrodes.

Piezoelectric Benders

Piezoelectric benders are often used to create actuators with large displacement capabilities (Figure B4). The bender works in a mode which is very similar to the action of a bimetallic spring. Two separate bars or wafers of piezoelectric material are metallized and poled in the thickness expansion mode. They are then assembled in a + - + - stack and mechanically bonded. In some cases, a thin membrane is placed between the two wafers. The outer electrodes are connected together and a field is applied between the inner and outer electrodes. The result is that for one wafer the field is in the same direction as the poling voltage while the other is opposite to the poling direction. This means that one wafer is increasing in thickness and decreasing in length while the other wafer is decreasing in thickness and increasing in length, resulting in a bending moment.

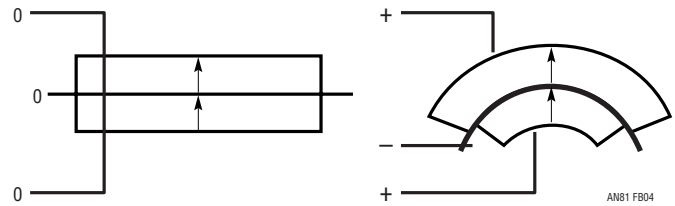

Figure B4

Loss

There are two sources for loss in a piezoelectric device. One is mechanical, the other is electrical.

$$\text{Mechanical Loss: } Q_M = \frac{\text{Mechanical Stiffness or Mass Resistance}}{\text{Mechanical Resistance}}$$

$$\text{Electrical Loss: } \tan\delta = \frac{\text{Effective Series Resistance}}{\text{Effective Series Reactance}}$$

Simplified Piezoelectric Element Equivalent Circuit

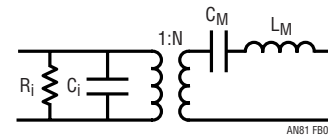

Figure B5

R_i = Electrical resistance

$$C_i = \text{Input capacitance} = \frac{\epsilon_0 \epsilon_r A}{t}$$

$\epsilon_0 = 8.85 \times 10^{-12}$ farads/meter

A = Electrode area

t = Dielectric thickness

L_M = Mass (Kg)

C_M = Mechanical compliance = 1/Spring Rate (M/N)

N = Electro-mechanical Linear Transducer Ratio (newtons/volts or coulomb/meter)

This model (Figure B5) has been simplified and it is missing several factors. It is only valid up to and slightly beyond resonance. The first major problem with the model is related to the mechanical compliance (C_M). Compliance is a function of mounting, shape, deformation mode (thickness, free bend, cantilever, etc.) and modulus of

elasticity. The modulus of elasticity is, however, anisotropic and it varies with electrical load. The second issue is that the resistance due to mechanical Q_M has been left out. Finally, there are many resonant modes in the transformers, each of which has its own C_M as shown in Figure B6.

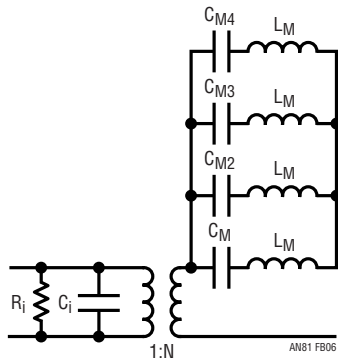

Figure B6

Mechanical Compliance:

Mechanical compliance, which is the inverse of spring constant, is a function of the shape, mounting method, modulus and type of load. Some simple examples are shown in Figure B7.

The various elements that have been explained can now be combined into the design of a complete piezoelectric device. The simple piezoelectric stack transformer will be used to demonstrate the way they are combined to create a functional model.

Simple Stack Piezoelectric Transformer

The piezoelectric transformer acts as an ideal tool to explain the modeling of piezoelectric devices in that it utilizes both the direct and indirect piezoelectric effects. The transformer operates by first converting electrical energy into mechanical energy in one half of the transformer. This energy is in the form of a vibration at the acoustic resonance of the device. The mechanical energy

SIMPLE BEAM—UNIFORM END LOAD

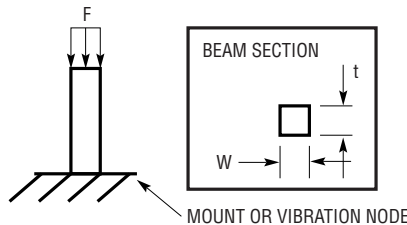

$$C_M = \frac{A}{AY_{ij}} = \frac{A}{Wt}$$

$$L_M = \rho AWt$$

SIMPLE BEAM—UNIFORM LOAD—END MOUNTS

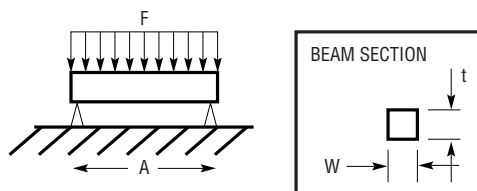

$$C_M = \frac{5A^3}{384Y_{ij}l}$$

$I = \text{MOMENT OF INERTIA}$

$$= \frac{Wt^3}{12}$$

$$C_M = \frac{5A^3}{32Wt^3}$$

SIMPLE BEAM—UNIFORM LOAD—CANTILEVER MOUNTS

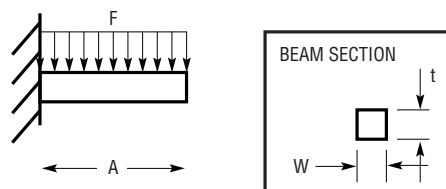

$$C_M = \frac{A^3}{8Y_{ij}l}$$

$$= \frac{3A^3}{2Y_{ij}Wt^3}$$

AN81 FB07

Figure B7

Application Note 81

produced is then mechanically coupled into the second half of the transformer. The second half of the transformer then reconverts the mechanical energy into electrical energy. Figure B8 shows the basic layout of a stack transformer. The transformer is driven across the lower half (dimension d_1) resulting in a thickness mode vibration. This vibration is coupled into the upper half and the output voltage is taken across the thinner dimension d_2 .

Equivalent Circuit:

The equivalent circuit model for the transformer (shown in Figure B9) can be thought of as two piezoelectric elements that are assembled back to back. These devices are connected together by an ideal transformer representing the mechanical coupling between the upper and lower halves. The input resistance, R_i , and the output resistance, R_o , are generally very large and have been left out in this model. The resistor R_L represents the applied load. Determining the values of the various components can be calculated as shown previously.

Input/Output Capacitance:

$$C_i = \epsilon_0 \epsilon_r \frac{\text{Input Area}}{\text{Input Thickness}} = \epsilon_0 \epsilon_r \frac{AW}{d_1}$$

similarly,

$$C_o = \epsilon_0 \epsilon_r \frac{\text{Output Area}}{\text{Output Thickness}} = \epsilon_0 \epsilon_r \frac{nAW}{d_2}$$

Mechanical Compliance:

The mechanical compliance, C_M , can be represented by a simple beam subjected to a uniform axial load. This is because the thickness expansion mode will apply uniform stress across the surface. It should be noted that the beam length is measured with respect to the vibration node. The vibration node is used as this is the surface which does not move at resonance and can, therefore, be thought of as a fixed mounting surface.

$$C_M = \frac{\text{Beam Length}}{\text{Beam Area } Y_{33}}$$

$$C_{M1} = \frac{d_1}{AWY_{33}}$$

$$C_{M2} = \frac{d_2}{AWY_{33}}$$

Note: Even if $nd_2 \neq d_1$ the vibration node will still be located in the mechanical center of the transformer.

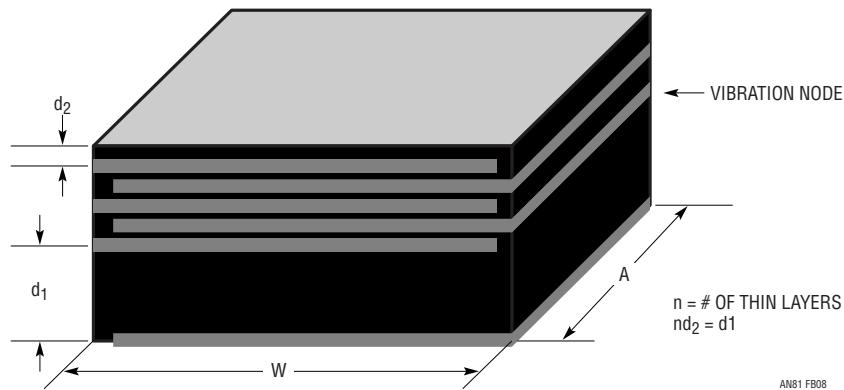

Figure B8

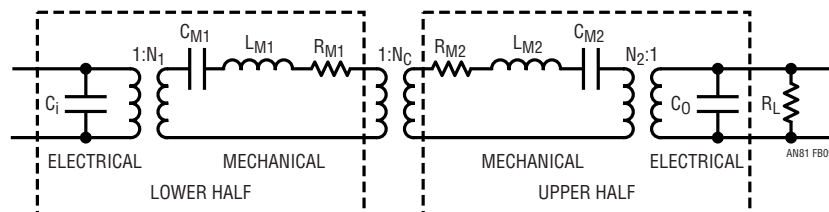

Figure B9

Mass:

$$L_{M1} = \rho A W d_1$$

$$L_{M2} = \rho A W d_2 = \rho A W d_1$$

Resistance:

The resistances in the model are a function of the mechanical Q_M and Q of the material at resonance and will be calculated later.

Ideal Transformer Ratio:

The transformer ratio, N_1 , can be thought of as the ratio of electrical energy input to the resulting mechanical energy output. This term will then take the form of newtons per volt and can be derived from the piezoelectric constant, g .

As before:

$$g = \text{Electrical Field Stress} = \frac{\text{Volts / Meter}}{\text{Newtons / Meter}^2}$$

therefore:

$$\frac{1}{g} = \frac{n / m}{V / m}$$

$$N_1 = \frac{1}{g} = \frac{\text{Area of Applied Force}}{\text{Length of Generated Field}}$$

or

$$N_1 = \frac{AW}{g_{33}d_1}$$

The output section converts mechanical energy back to electrical energy and the ratio would normally be calculated in an inverse fashion to N_1 . In the model, however, the transformer ratio is shown as $N_2 : 1$. This results in a calculation for N_2 that is identical to the calculation of N_1 .

$$N_2 = \frac{1}{g} = \frac{\text{Area of Applied Force}}{\text{Length of Generated Field}}$$

or

$$N_2 = \frac{AW}{g_{33}d_2}$$

The transformer $1 : N_C$, represents the mechanical coupling between the two halves of the transformer. The stack transformer is tightly coupled and the directions of stress are the same in both halves. This results in $N_C \cong 1$.

Model Simplification:

The response of the transformer can be calculated from this model, but it is possible to simplify the model through a series of simple network conversion and end up in an equivalent circuit whose form is the same as that of a standard magnetic transformer (Figure B10).

where, due to translation through the transformer,

$$C_{M2}' = N_C^2 C_{M2} \quad \text{and} \quad L_{M2}' = L_{M2} / N_C^2$$

but $N_C^2 \cong 1$, therefore

$$C_{M2}' = C_{M2} = C_{M1} \quad \text{and} \quad L_{M2}' = L_{M2} = L_{M1}$$

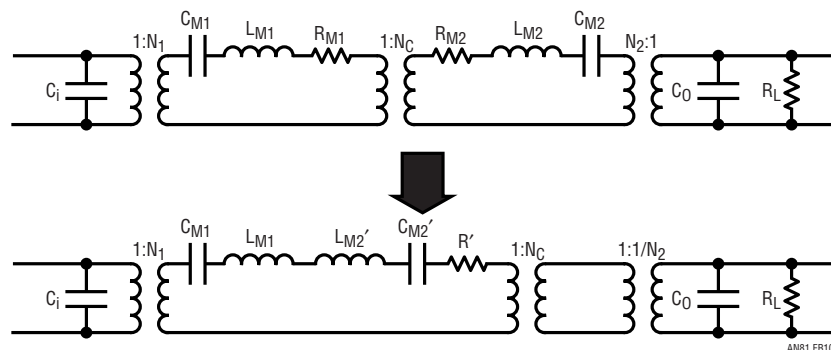

Figure B10

Application Note 81

which allows the next level of simplification (Figure B11)

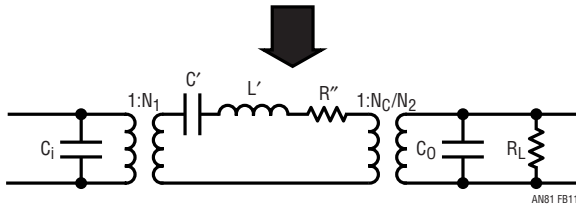

Figure B11

here

$$L' = L_{M1} + L_{M2}' = 2L_1 = 2\rho AWd_1$$

$$C' = \frac{\left(\frac{C_{M1}C_{M2}'}{C_{M1} + C_{M2}'} \right)}{\left(\frac{C_{M1}^2}{2C_{M1}} \right)} = \frac{C_{M1}^2}{2} = \frac{C_{M1}}{2} = \frac{d_1}{2AWY_{33}}$$

Final simplification (Figure B12)

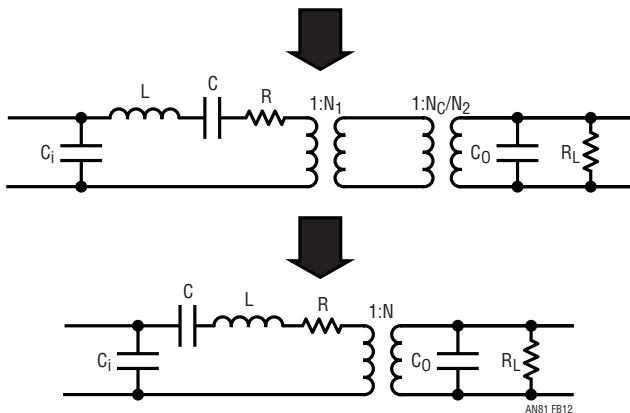

Figure B12

where

$$C = C'N_1^2 \text{ and } L = L'/N_1^2$$

and, from before

$$N_1 = \frac{AW}{g_{33}d_1}$$

therefore

$$C = \frac{d_1}{2WLY_{33}} \frac{A^2W^2}{g_{33}^2 d_1^2} = \frac{AW}{2Y_{33}g_{33}^2 d_1}$$

$$L = 2\rho AWd_1 \frac{g_{33}^2 d_1^2}{A^2W^2} = \frac{2\rho g_{33}^2 d_1^2}{AW}$$

$$N = \frac{N_1 N_C}{N_2} = \frac{AW}{g_{33}d_1} \frac{g_{33}d_2}{AW} = \frac{d_2}{d_1}$$

The last value we need to calculate is the motional resistance. This value is based upon the mechanical QM of the material and the acoustic resonant frequency.

Resonant Frequency

$$\omega_0 = 1/\sqrt{LC}$$

$$= \frac{1}{\sqrt{\frac{2\rho d_1 g_{33}^2}{AW} \frac{AW}{2Y_{33}g_{33}^2 d_1}}}$$

$$= \frac{1}{\sqrt{\frac{\rho d_1^2}{Y_{33}}}} = \frac{1}{d_1 \sqrt{\frac{\rho}{Y_{33}}}}$$

$$c_{PZT} \equiv \text{Speed of Sound in PZT} = \sqrt{Y/\rho}$$

therefore

$$\omega_0 = c_{PZT}/d_1$$

The equation above states that the resonant frequency is equal to the speed of sound in the material divided by the acoustic length of the device. This is the definition of acoustic resonance and acts as a good check of the model. The final derivation is the value of resistance.

$$Q_M \equiv 1/\omega_0 RC$$

or

$$R = 1 / \omega_0 Q_M C$$

$$R = \frac{d_1 \sqrt{\rho Y_{33}}}{Q_M} \frac{2 Y_{33} g_{33}^2 d_1}{AW}$$

$$= \frac{2 d_1^2 g_{33}^2 \sqrt{\rho Y_{33}}}{Q_M AW}$$

Note: C_M and R are both functions of Y_{33} and Y_{33} is a function of R_L

It should be noted that the model is only valid for transformers driven at or near their fundamental resonate frequencies. This is because the initial mechanical model assumed a single vibration node located at the center of the stack which is only true when the transformer is driven at fundamental resonance. There are more nodes when the transformer is driven at harmonic frequencies (Figure B13).

There are no fixed nodes at frequencies other than resonance. This means that the transformer must be designed with the resonate mode in mind or phase cancellations will occur and there will be little or no voltage gain. It is often difficult to understand the concept of nodes and phase cancellation, so a simple analogy can be used. In this case, waves created in a waterbed will be used to explain the effect.

Pressing on the end of a waterbed creates a “wave” of displacement that travels down the length of the bed until it reaches the opposite end and bounces back. The water pressure (stress) is the lowest, or negative with respect to the water at rest, at a point just in front of the wave and highest at a point just behind the wave. The pressures at the crest and in the trough are at the same pressure as the bed at rest. The wave will reflect back and forth until resistance to flow causes it to dampen out. The average pressure over time at any point in the bed will be exactly the same as the pressure at rest. Similarly, the average stress in a transformer off resonance will approach zero and there will be no net output.

Pressing on the end of the same bed repeatedly just after the wave has traveled down the length, reflected off the end, returned and reflected off the “driven” end will result in a standing wave. This means that one half of the bed is getting thicker as the other half is getting thinner and the center of the bed will be stationary. The center is the node and the thickness plotted over time of either end will form a sine wave. There will be no net pressure difference in the center, but the ends will have a pressure wave which form a sine wave 90° out of phase with the displacement. The transformer again works in the same manner with no voltage at the node and an AC voltage at the ends. It is fairly simple to expand this concept to harmonics and to other resonate shapes.

Conclusion

The number of different applications for piezoelectric ceramic, and in particular PZT ceramic, is too great to address in a single paper. The basic principals that have been set forth in this primer can, however, be used to both understand and design piezoelectric structures and devices. The ability to create devices of varying applications and shapes is greatly enhanced by the used of multilayer PZT ceramics.

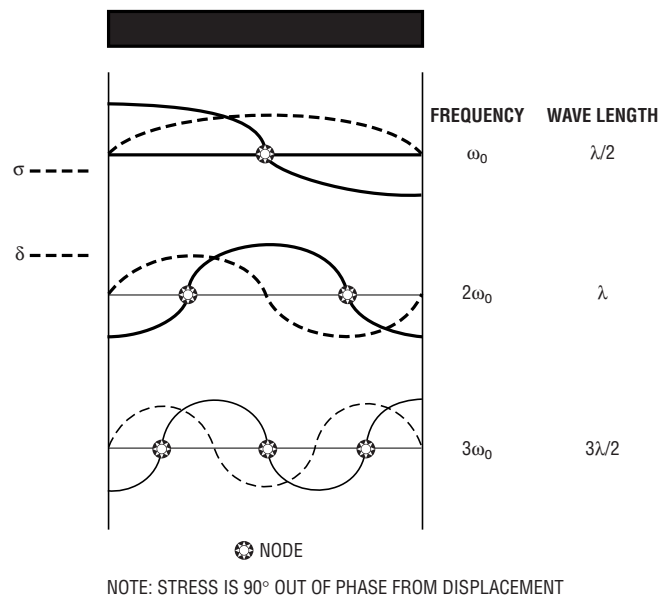

Figure B13

APPENDIX C

A Really Interesting Feedback Loop

The almost pure mechanical delay presented by the PZT's acoustic transport presents a fascinating exercise in loop compensation.¹ Veterans of feedback loop compensation battles will exercise immediate caution when confronted with a pure and lengthy delay in a loop. Neophyte designers will gain a lesson they will not easily forget.

Figure C1 diagrams Figure 9's amplitude control loop, with significant contributions to loop transmission represented. The PZT delivers phase delayed information at about 60kHz to the lamp. This information is smoothed to DC by the RC averaging time constant and delivered to the LT1375's feedback terminal. The LT1375 controls PZT power with its 500kHz PWM output, closing the control loop. The capacitor at the LT1375's V_C pin rolls off gain, nominally stabilizing the loop. This compensation capacitor must roll off gain-bandwidth at a low enough value to prevent loop delays from causing oscillation. Which of these delays is the most significant? From a stability viewpoint, the LT1375's output repetition rate and the PZT's oscillation frequency are sampled data systems. Their information delivery rate is far above the PZT's 200 μ s delay and the averaging time constants, and is not significant. The PZT delay and the RC time constant are the major contributors to loop delay. The RC time constant must be large enough to turn the half wave rectified waveform into DC. The lumped delay of the PZT and the RC thus dominates loop transmission. It must be compensated by the capacitor at the LT1375 V_C pin. A large enough value for this capacitor rolls off loop gain at low enough frequency to provide stability. The loop simply does not have enough gain to oscillate at a frequency commensurate with the RC and PZT delays.²

A good way to begin to establish a value for loop roll-off is to let the loop oscillate. This is facilitated by initially deleting the compensation capacitor and turning the circuit on. Figure C2 shows the V_C pin (trace A) and FB node (trace B). The frequency of oscillation and the phase relationship between these two signals provide valuable insight into achievable closed-loop bandwidth.³ Loop delay sets oscillation frequency at about 2.3kHz. Selecting

the V_C value to roll off bandwidth well below this frequency is appropriate. Figure C3 shows results with Figure 9's 4.7 μ F capacitor installed. Trace A, a step input, is applied to the LT1375's shutdown pin. When the shutdown pin is enabled, V_C (trace B) slews up and the feedback pin (trace C) moves toward its control point as PZT output voltage (trace D) rises. The V_C pin damping causes extended slew time but settling is completed in 25 milliseconds with minimal overshoot. The small overshoot (past mid screen) derives from the lamp's negative resistance characteristic and is easily handled by loop dynamics.

Some situations may require significantly faster loop response than simple first order compensation can provide. An example is wide range dimming via PWM methods. Such methods rely on rapid on-off loop cycling to achieve wide range dimming. Typically, the cycling occurs well above the flicker rate, in the 100Hz to 200Hz region. Loop settling must be very quick with respect to this frequency or line regulation will be poor. This is so because during slew the loop is out of control. If slew time approaches on-time, control is, by definition, poor. Figure C4 uses a feedback lead, allowing very light V_C damping with resultant faster slew time.⁴ Figure C5 shows results. When the shutdown pin (trace A) is enabled, V_C (trace B) slews rapidly, followed by the FB node (trace C). The PZT high voltage envelope is trace D. Loop capture occurs in 1.2 milliseconds—about 20x faster than Figure C3's simple first order compensation. Note that this performance begins to approach the limits implied by Figure C2's information.⁵

Note 1: Perhaps this verbiage indulges drama. Conversely, nerds like me find arcana such as this fascinating.

Note 2: The high priests of feedback refer to this as "Dominant Pole Compensation." The rest of us are reduced to more pedestrian descriptors. As such, this technique is sometimes loosely referred to as "glop comp."

Note 3: Deliberately sustaining loop oscillation is a valuable investigative tool but may encounter problems in some applications. Consider aircraft flap control servos or power plant generator stabilizing loops.

Note 4: Proper Bode for this compensation technique is a "feedback zero."

Note 5: Score one for lightning empiricism.

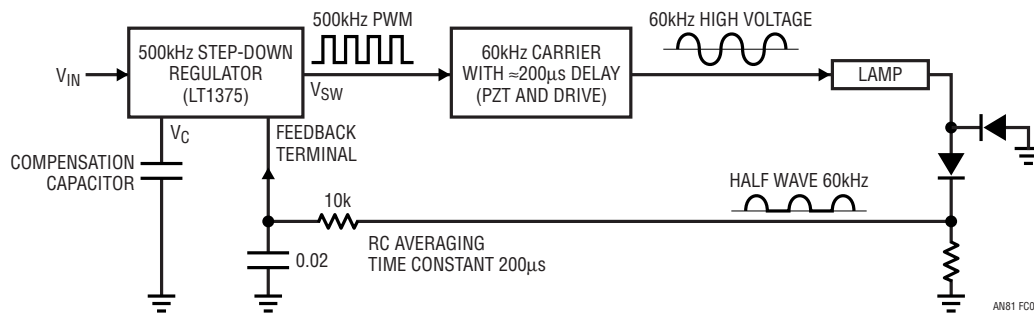

Figure C1. Delay Terms in Figure 9's Amplitude Control Feedback Path. PZT's 200µs Mechanical Delay and RC Time Constant Dominate Loop Transmission and Must Be Compensated for Stable Operation

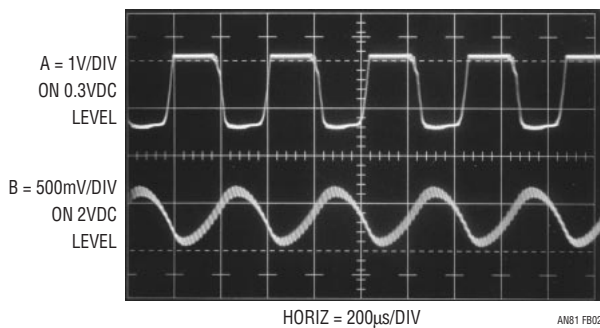

Figure C2. Allowing Loop to Oscillate Hints at Compensation Requirements. 2.3kHz Oscillation Frequency Appears to Derive from Figure C1's Delay Terms. Trace A Is LT1375 VC Pin, Trace B Its Feedback Terminal. High Frequency Content in Trace B's Outline, PZT Carrier Residue, Is Not Pertinent

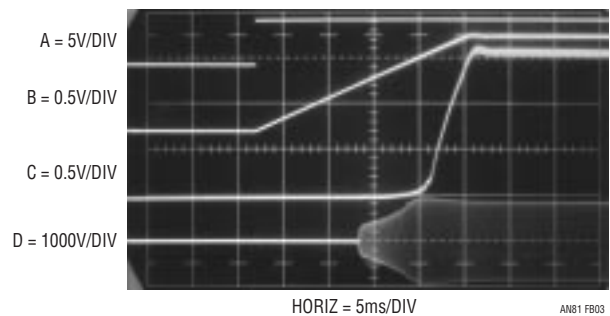

Figure C3. Figure 9's Loop Compensation Is Stable Despite PZT's Mechanically Induced Delay. First Order Roll-Off from Large VC Pin Capacitor Stabilizes Loop. Trace A Is Step Input at LT1375 Shutdown Pin. Traces B, C and D are VC, Feedback and PZT Output Nodes, Respectively

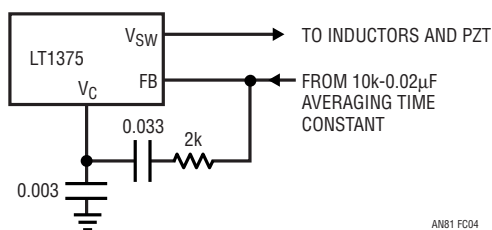

Figure C4. Very Light VC Damping Augmented by a Feedback Lead Provides 20× Faster Loop Response. Technique Allows Wide Range Lamp Dimming Via PWM without Sacrificing Line Regulation

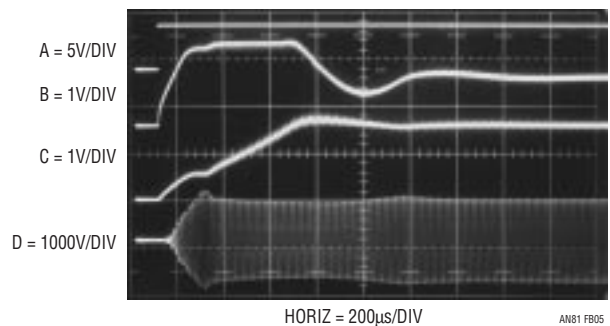
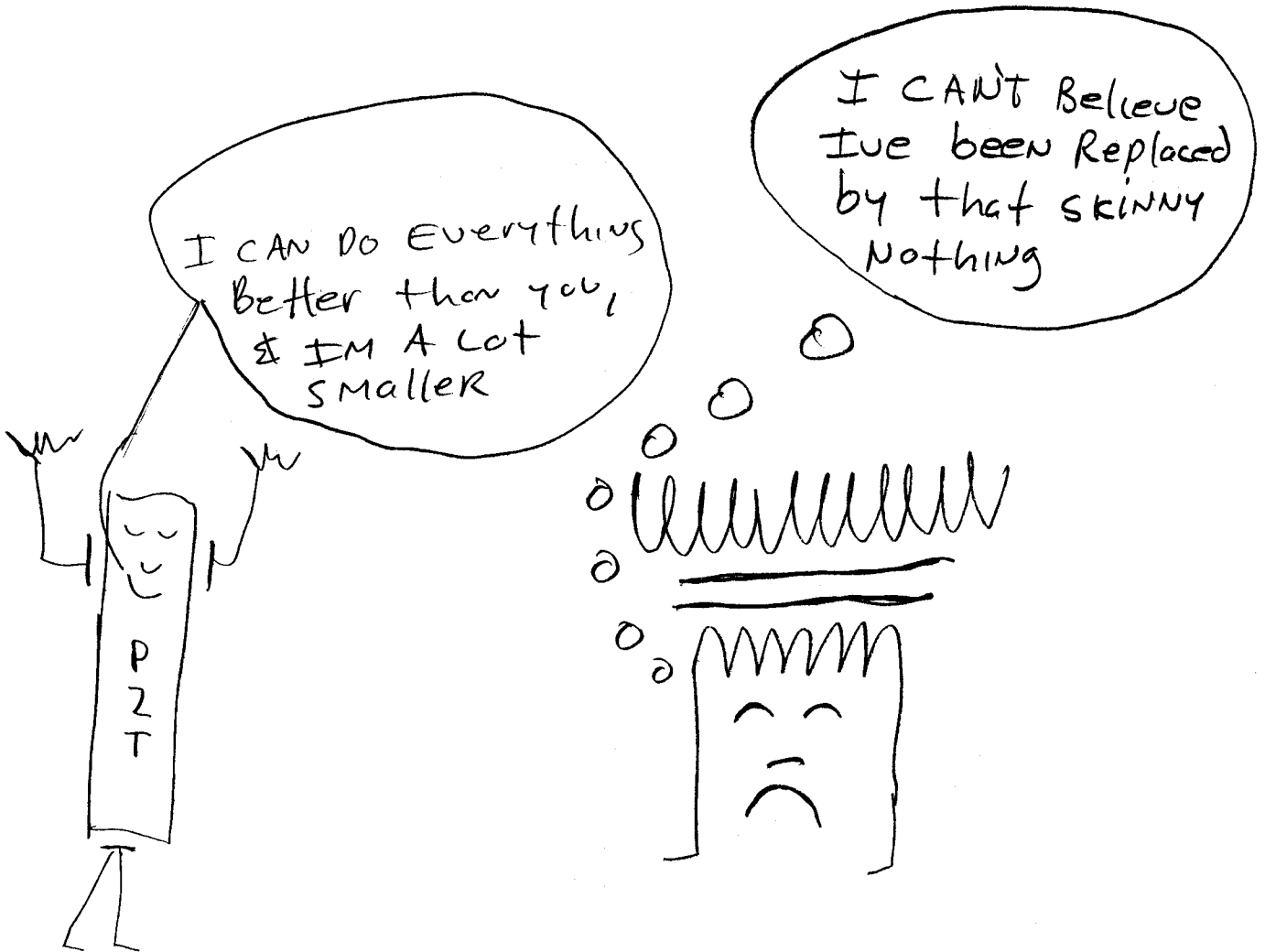

Figure C5. Feedback Based Compensation Waveforms. Trace A Is Step Input at LT1375 Shutdown Pin. Traces B, C and D Are VC, Feedback and PZT Output Nodes, Respectively. Note 25× Sweep Speed Increase Over Figure C3



www '99