

Using the AD7782 in Low Power Applications

by Mary McCarthy

INTRODUCTION

This application note describes how to use the AD7782 in portable or low power applications. The part is a read-only, pin configurable, 24-bit device with a 20 Hz output word rate. It contains two differential analog input channels and can be used with an analog input range of ± 160 mV or ± 2.56 V. The input signal range and input channel selection are configured using external pins. The serial data interface on the AD7782 allows the user to power down the device between conversions, which reduces the average current consumption of the part.

Serial Interface

As shown in Figure 1, the AD7782 has a 3-wire serial interface: DOUT/RDY, SCLK, and \overline{CS} . The MODE pin

allows the part to be used in slave mode (the SCLK is provided externally) or in master mode (the AD7782 provides the SCLK). When the device is powered up, it will continuously convert with an update rate of 19.79 Hz. The \overline{CS} pin operates as a power-down pin as well as operating as a chip-select pin. When \overline{CS} is high, continuous ADC conversions are halted, DOUT/RDY becomes three-stated, the AD7782 enters standby mode, and any conversion result in the output shift register is lost. The SCLK will also be three-state in master mode. The crystal oscillator on-board the AD7782 remains active in power-down mode. When \overline{CS} goes low, the phase locked loop (PLL) on-board the AD7782 establishes lock, and the part then begins converting the selected channel.

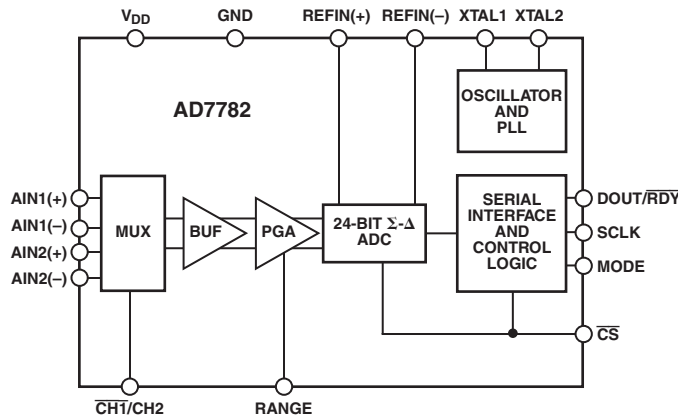

Figure 1. AD7782 Functional Block Diagram

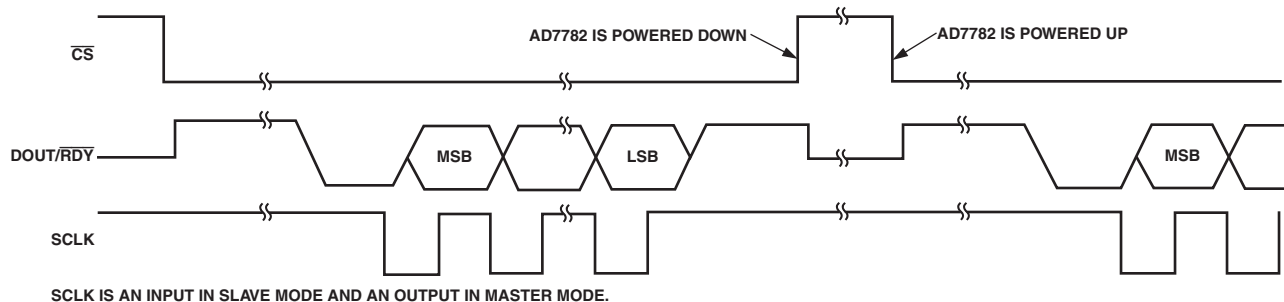

Figure 2. AD7782 Timing Diagram

Current Consumption

When the AD7782 is powered up, it consumes 1.3 mA typical at 3 V and 1.5 mA typical at 5 V. In power-down mode, the device consumes 6 μ A typical at 3 V and 20 μ A typical at 5 V. By placing the AD7782 in power-down mode between conversions, the current consumption can be optimized. For example, if the AD7782 is used to perform one conversion each second, the device can be powered up to perform the conversion and then powered down using \overline{CS} until the next conversion is required.

As seen in Figure 2, taking \overline{CS} low powers up the AD7782. After power-up, the ADC requires some time to settle (approximately 1 ms). Following this, the part begins to convert. The sigma-delta ADC uses chopping, which results in two conversion periods being needed to generate a correct conversion result after bringing the part out of power-down mode. \overline{RDY} will remain high until a valid conversion result is available. With an update rate of 19.79 Hz, the conversion period is 50.5 ms. Therefore, the AD7782 must remain powered-up for $(2 \times 50.5) + 1 = 102$ ms. When the conversion is read, the device can be powered down.

If one conversion per second is required in an application, the device will be powered up for 102 ms and placed in power-down mode for $(1000 - 102) = 898$ ms. Assuming a 3 V power supply, the average current equals $(0.898 \times 6) + (0.102 \times 1300) = 138 \mu$ A.

With a 5 V power supply and, again, with one conversion per second, the average current equals $(0.898 \times 20) + (0.102 \times 1500) = 171 \mu$ A.

In some applications, the AD7782 is used for monitoring functions in which the part performs one conversion each hour. In this case, the average current drawn with a 3 V power supply is $(0.99997167 \times 6) + (0.00002833 \times 1300) = 6.04 \mu$ A.

With a 5 V power supply, the average current equals $(0.99997167 \times 20) + (0.00002833 \times 1500) = 20.04 \mu$ A.

Figure 3 shows a plot of average current versus conversion rate, the conversion rate being the period of time in which the ADC performs a single conversion, the AD7782 being placed in power-down mode after the single conversion. From the plot, the average current approaches the power-down current specification when the time interval between conversions is 15 seconds or greater.

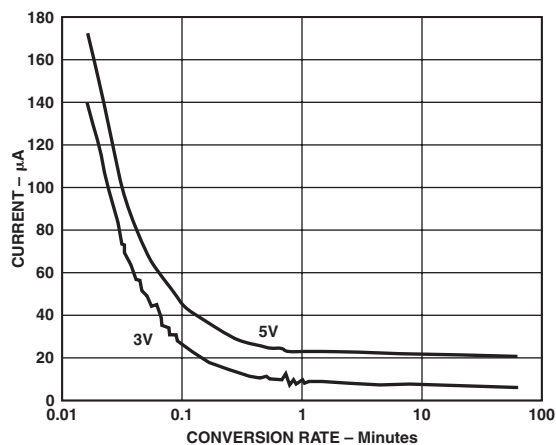

Figure 3. Current Consumption vs. Conversion Rate

Summary

The AD7782 ADC continuously converts when it is powered up. However, for many applications, many of these conversions will not be read as the application may require a much slower update rate. In such applications, powering down the AD7782 between conversions will reduce the current. Since \overline{CS} operates as both a chip-select pin and a power-down pin, powering down the ADC between conversions does not add additional overhead because no additional digital pins from the microcontroller are required.