

Calibrating a Three-Phase Energy Meter Based on the [ADE7880](#)

by Aileen Ritchie

INTRODUCTION

This application note describes how to calibrate the [ADE7880](#). Details on the calibration procedure, including equations and examples of how to calculate each constant are provided.

The [ADE7880](#) is a high accuracy, 3-phase electrical energy measurement IC with serial interfaces and three flexible pulse outputs. The [ADE7880](#) device incorporates second-order sigma-delta (Σ - Δ) analog-to-digital converters (ADCs), a digital integrator, reference circuitry, and all of the signal processing required to perform the total (fundamental and

harmonic) active, and apparent energy measurements, rms calculations, as well as fundamental-only active and reactive energy measurements. In addition, the [ADE7880](#) computes the rms of harmonics on the phase and neutral currents and on the phase voltages, together with the active, reactive, and apparent powers, and the power factor and harmonic distortion on each harmonic for all phases. Total harmonic distortion plus noise (THD + N) is computed for all currents and voltages.

TABLE OF CONTENTS

Introduction	1	Gain Matching	7
Revision History	2	Energy Calibration	8
Calibration Basics	3	Phase Calibration (Optional).....	8
Calibration Steps.....	3	Current and Voltage RMS	10
Calibration Method (CF Output or Registers)	3	Calibrating Using the Energy Registers.....	12
Calibration Setups	4	Gain Matching	12
Calibration Inputs	4	Phase Calibration (Optional).....	12
Required Register Settings	5	Energy Gain Calibration	13
Calibrating Using the CF Pulse Output.....	6	Current and Voltage RMS	15

REVISION HISTORY

3/13—Rev. 0 to Rev. A

Change to Title.....	1
----------------------	---

11/12—Revision 0: Initial Version

CALIBRATION BASICS

To obtain accurate readings that do not reflect meter-to-meter variations in external components or the internal voltage reference, the [ADE7880](#) requires calibration. Calibration is required on every meter; however, it is a simple process that can be performed quickly.

CALIBRATION STEPS

When designing a meter using the [ADE7880](#), a maximum of three calibration stages are required: gain, phase, and offset. Depending on the external configuration and meter class, one or more of these stages can be omitted.

Table 1 provides guidance on which calibration steps are typically required for a particular configuration. Because the requirements and performance can differ on a design-by-design basis, use Table 1 only as a general guideline. The performance of the meter should be evaluated to determine whether any additional calibration steps are required.

CALIBRATION METHOD (CF OUTPUT OR REGISTERS)

The [ADE7880](#) can be calibrated by either reading the internal energy registers or measuring the external calibration frequency (CF) output pulse. The relationship between these two measurements is shown in Figure 1.

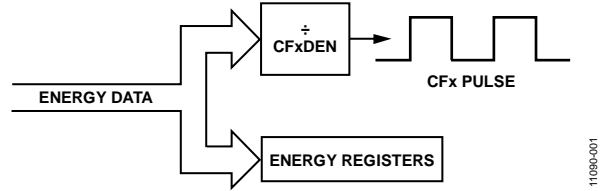

Figure 1. Accessing Energy Data

As shown in Figure 1, the energy register data and CFx output data are related by a factor of the CFxDEN register.

$$CFxOutput \text{ (Hz)} = 1/CFxDEN \times \text{Energy Register (Update Rate)}$$

The decision of whether to calibrate using the CF or energy register depends on both the application and available calibration equipment (see the Calibration Setups section).

If the meter specification requires calibration to a particular meter constant, the CF output pin is typically used. If the CF output pin is not being used and no meter constant is specified by design, the register may be a more convenient method. Calibrating the energy registers result in accurate readings on the CF output pin and vice versa. Both methods result in the same level of accuracy.

Table 1. Typical Calibration Steps

Calibration Stage	Typical Requirement
Gain Calibration	It is always required.
Phase Calibration	When using a current sensor that introduces a phase delay, such as a current transformer (CT) or Rogowski coil, it is often required. When using a current sensor that does not introduce a delay it is not typically required.
Offset Calibration	When looking for high accuracy over a large dynamic range, it is often required. It is not usually required for all other meter designs.

CALIBRATION SETUPS

Two calibration setups can be used to calibrate the ADE7880: a reference meter or an accurate source. When using a reference meter, the CF output method of calibrating must be used. When using an accurate source, either the CF output or energy register can be used. Additional information on the two calibration setups are in the Reference Meter section and the Accurate Source section.

Reference Meter

The most popular method of calibration uses an external reference meter to determine the required compensation. If using reference metering, the CF output must be used because the reference meter determines the error based on the CF pulse (see Figure 2). The reference meter should be more accurate than desired specifications of the resulting meter.

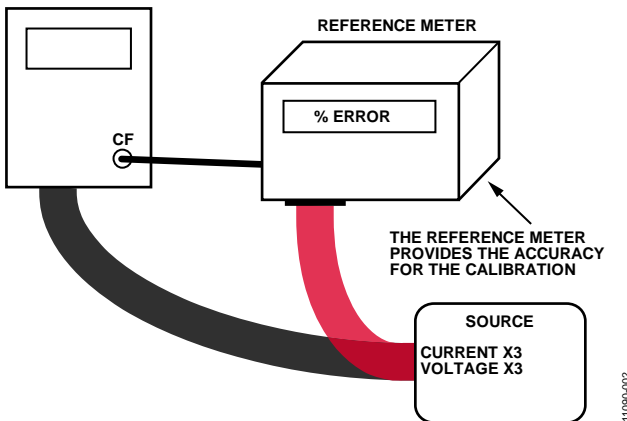

Figure 2. Reference Meter Configuration

When using a reference meter, a source is required to provide the required inputs to the meter; however, the accuracy of the source is not as critical because the reference meter determines the calibration result. Typically, reference meters are more cost effective than accurate sources; therefore, this is the most popular calibration method.

Accurate Source

The second calibration method is to use an accurate source to perform the calibration. If using an accurate source, either the CF output or the energy registers can be used to access the energy data. The accurate source must be able to provide a controllable voltage and current input with higher accuracy than that required in the resulting meter. Figure 3 shows a typical setup using an accurate source.

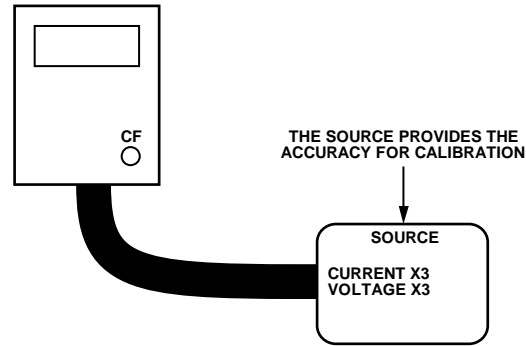

Figure 3. Accurate Source

An accurate source is typically more expensive than a reference meter and is, therefore, a less popular method of calibration.

CALIBRATION INPUTS

As shown in Table 1, a maximum of three calibration steps are required. Each calibration step requires a separate measurement to be taken and calculation to be performed. To allow the separate gain, phase, and offset errors to be extracted, three separate sets of input conditions are typically required. These are shown in Table 2.

Table 2. Typical Input Conditions

Calibration Step	Voltage Input	Current Input	Power Factor
Phase	Nominal	Nominal	0.5
Gain	Nominal	Nominal	1
Offset	Nominal	Minimum	1

where:

The nominal voltage is typically 110 V or 220 V.

The nominal current is typically around 1/10 of the maximum current, such as 10 A.

The minimum current is the minimum current specified in the meter while staying within the specification of the measurement for the ADE7880, such as 100 mA.

To speed up the calibration procedure and minimize the number of input conditions, the gain calibration can also be performed at a power factor of 0.5. This allows one single calibration point to be used for both the gain and phase calibration. In many cases, this reduces the total calibration procedure to one single point since offset calibration is not always required.

Table 3 shows the modified calibration conditions.

Table 3. Modified Input Conditions

Calibration Step	Voltage Input	Current Input	Power Factor
Phase	Nominal	Nominal	0.5
Gain	Nominal	Nominal	0.5
Offset	Nominal	Minimum	1

When using the input conditions shown in Table 3, it is important that the power factor used is as close to 0.5 as possible and that it is not varying. Note that an inductive or capacitive load can be used. This application note provides example calculations with the modified input conditions shown in Table 3.

REQUIRED REGISTER SETTINGS

Prior to calibrating the [ADE7880](#), it is important that a set of registers are configured. These registers are listed in Table 4. Refer to the [ADE7880](#) data sheet for details on these registers.

Table 4. Default Registers Required Prior to Calibration

Register Address	Register Name	Register Description	Suggested Value	Comment
0xEA02	WTHR	Threshold register for active energy	0x03	See the ADE7880 data sheet, Equation 26 for details on modifying this constant.
0xEA03	VARTHR	Threshold register for reactive energy	0x03	See the ADE7880 data sheet, Equation 37 for details on modifying this constant.
0xEA04	VATHR	Threshold register for apparent energy	0x03	See the ADE7880 data sheet, Equation 44 for details on modifying this constant.
0x4388	DICOEFF	Digital integrator algorithm; required only if using di/dt sensors	0xFFFF8000	Only required when using a Rogowski coil
0x439F	VLEVEL	Threshold register used in fundamental only calculation	0x38000	See the ADE7880 data sheet, Equation 22 for details on modifying this constant. Required for fundamental only readings.
0xE60E	COMPMODE[14] (SELFREQ)	50 Hz or 60 Hz selection for fundamental only measurement	50 Hz 0 60 Hz 1	Required for fundamental only readings.

CALIBRATING USING THE CF PULSE OUTPUT

When calibrating using the pulse output, the CFx pin must be configured to output the measurement and channel that is being calibrated. For example, when calibrating active energy on Channel A, configure CF1, CF2, or CF3 to be proportional to the active power on Channel A. This is achieved by setting Bit 0 through Bit 8 of the CFMODE register (Address 0xE610) as well as Bit 0 through Bit 8 of the COMPMODE register (Address 0xE60E). CF1, CF2, or CF3 can be used.

For faster calibration, multiple different measurements or channels can be output on CF1, CF2, and CF3, simultaneously, with up to three calibrations performed in parallel. This allows all three phases to be calibrated simultaneously.

Figure 4 shows the calibration flow for the energy measurement. Use this flow to determine a calibration routine.

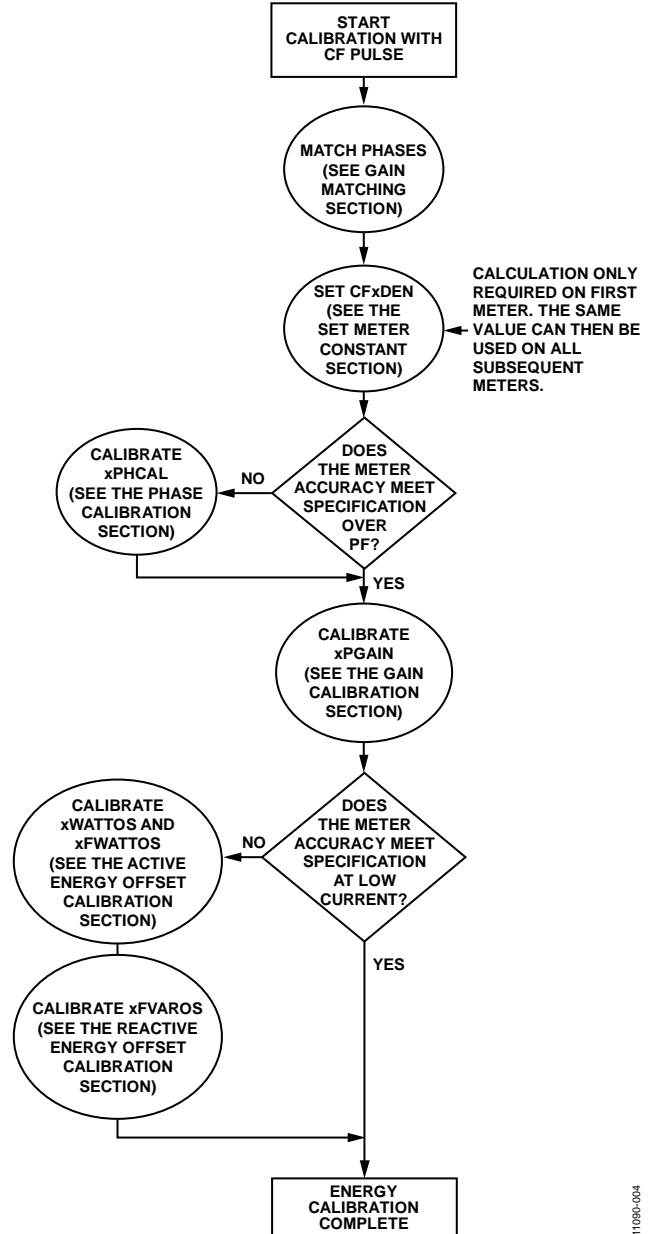

Figure 4. Energy Calibration Flow

11090-004

GAIN MATCHING

Table 5. xGAIN

Calibration Registers	Address
AIGAIN	0x4380
BIGAIN	0x4382
CIGAIN	0x4384
AVGAIN	0x4381
BVGAIN	0x4383
CVGAIN	0x4385

It is convenient to match all three phases prior to calibrating. Matching the phases results in easier computations because one pulse on the CF output has the same weight on each phase. It is recommended that phase matching be performed as the first calibration step.

To match phase current B and phase current C to phase current A, apply the same fixed input current to all phase currents. Because the meter has not yet been calibrated, it is recommended that the amplitude of the applied signal be between full scale and 100:1. The current rms reading can then be used to determine if there is any error between the phase currents. This error can then be corrected using the BIGAIN register (Address 0x4382) and the CIGAIN register (Address 0x4384).

The following equation describes how to adjust the BIRMS and CIRMS readings to match that in AIRMS using the BIGAIN register and CIGAIN register respectively:

$$BIGAIN = 2^{23} \times \left[\frac{AIRMS}{BIRMS} - 1 \right]$$

$$CIGAIN = 2^{23} \times \left[\frac{AIRMS}{CIRMS} - 1 \right]$$

It is recommended that the xIRMS measurements are taken synchronous to the zero crossing interrupt to reduce ripple. It is also recommended that some averaging be performed to obtain a more stable reading.

The same procedure can then be used on the voltage channels to match the xVRMS readings. The voltage channel gain register BVGAIN (Address 0x4383) and CVGAIN (Address 0x4385) can be used to match the BVRMS and CVRMS to the AVRMS measurement, respectively.

$$BVGAIN = 2^{23} \times \left[\frac{AVRMS}{BVRMS} - 1 \right]$$

$$CVGAIN = 2^{23} \times \left[\frac{AVRMS}{CVRMS} - 1 \right]$$

Once this step is complete, all phase currents and all phase voltages will have the same weight.

ENERGY CALIBRATION

Table 6. CFxDEN

Calibration Registers	Address
CF1DEN	0xE611
CF2DEN	0xE612
CF3DEN	0xE613

The CFx pulse output can be configured so that each pulse represents a fraction of a kWh. This relationship is known as the meter constant. Typically, design specifications require a particular meter constant to allow the utility to verify the accuracy of meters from multiple manufacturers. Typical meter constants are 1600 imp/kWh, 3200 imp/kWh, and 6400 imp/kWh. If designing a meter that does not require a specific meter constant, an arbitrary value can be chosen.

The CFx output is configured using the divider, CFxDEN. This divider is calculated based on the meter constant and the nominal scaling on the current and voltage channels.

Assuming a meter constant of 3200 imp/kWh is required, the expected CFx can be determined under a given load.

With a load of 220 V and 10 A at a power factor of 0.5, the CFx output frequency is calculated as follows:

$$CF_{EXPECTED} = \frac{\text{Meter Constant [imp/kWh]} \times \text{Load [kW]}}{3600 \text{ s/h}}$$

$$CF_{EXPECTED} = \frac{3200 \text{ imp/kWh} \times 220 \text{ V} \times 10 \text{ A} / 1000 \times \cos(60)}{3600 \text{ s/h}}$$

$$= 0.97778 \text{ Hz}$$

Select the CFxDEN to obtain a frequency of 0.97778 Hz under the given load conditions. This can be done by determining the scale on the input pins.

Figure 5 shows a standard voltage channel input network.

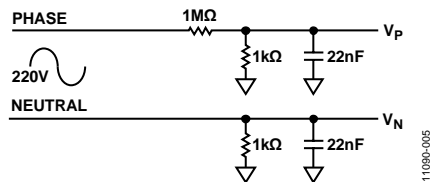

Figure 5. Voltage Channel Inputs

$$V_p = V_{INPUT_MAX} \times \frac{1 \text{ k}\Omega}{(1000 + 1) \text{ k}\Omega} =$$

$$(220 \text{ V} \times \sqrt{2}) \times \frac{1}{(1000 + 1)} = 0.311 \text{ mV}$$

$$V_{AS\% \text{ OF FULLSCALE}} = \frac{0.311}{0.5} \times 100 = 62.29\%$$

With a voltage channel amplitude of 220 V rms, the input is operating at 62.29% of full scale. Figure 6 shows a typical current

channel configuration. Assuming a CT turns ratio of 2500:1 and a burden resistor of 20 Ω, with a current channel amplitude of 10 A rms, the input operates at 16% of full scale.

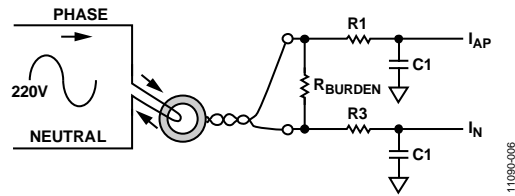

Figure 6. Current Channel Inputs

$$I_{AT \text{ CT Secondary}} = 10 \text{ A} / 2500 = 0.004 \text{ A}$$

$$V_{\text{Across Burden}} = I \times R = 0.004 \times 20 = 0.08 \text{ V}$$

$$I_{AS\% \text{ OF FULLSCALE}} = \frac{0.08}{0.5} \times 100 = 16\%$$

From the ADE7880 data sheet, the maximum CFx output with full-scale analog inputs is 68.818 kHz assuming WTHR = 3. When a PF of 0.5 is applied, this reduces to 34.409 kHz. To obtain 0.9778 Hz with the given 220 V, 10 A, PF = 0.5 input, the CF denominator should be set to 0xDB3, as shown:

$$CFxDEN = \frac{\text{Output Freq}_{FULLSCALE} \times V_{OPERATING\%} \times I_{OPERATING\%}}{CF_{EXPECTED}}$$

$$CFxDEN = \frac{34.409 \text{ kHz} \times 62.29\% \times 16\%}{0.97778 \text{ Hz}} = 0xDB3$$

Remember, writing 0xDB3 to the CFxDEN register sets the CF output to around 0.97778 Hz for the conditions previously described. This CFxDEN setting can now be used on every meter. The Gain Calibration provides a finer resolution calibration that should be done on every meter to ensure that the 0.97778 Hz is precisely met.

PHASE CALIBRATION (OPTIONAL)

Table 7. xPHCAL

Calibration Registers	Address
APHCAL	0xE614
BPHCAL	0xE615
CPHCAL	0xE616

Phase calibration is required when using a current transformer (CT) to remove any phase shift introduced by the sensor. CTs can add significant phase shift that introduce large errors at low power factors. If using a current sensor that does not introduce a phase delay calibration is not typically necessary as the ADE7880 is very well phase matched.

The phase calibration is ideally performed with an inductive or capacitive load at a power factor of 0.5. If this load is not available, another power factor can be chosen. For best results, the power factor should be as close to 0.5 as possible. To perform phase calibration in one step with one reading, the active and reactive

powers must be measured simultaneously. The following equation outlines how to determine the phase error in degrees.

$$Error(^{\circ}) = \tan^{-1} \left(\frac{CF_{Active} \sin(\varphi) - CF_{Reactive} \cos(\varphi)}{CF_{Reactive} \sin(\varphi) + CF_{Active} \cos(\varphi)} \right)$$

where:

φ refers to the angle between the voltage and the current (in degrees).

Once the error in degrees is determined, the following formula can be used to determine the required phase compensation.

$$PhaseResolution = \left(\frac{360^{\circ} \times f}{1.024 \text{ MHz}} \right)$$

$$PhaseCompensation = \text{abs} \left(\frac{Error(^{\circ})}{PhaseResolution} \right)$$

where:

f refers to the line frequency.

Note that the format of the APHCAL register is such that if the value of the Error(degrees) is positive then a value of 512d must be added to the calculated PhaseCompensation prior to writing to the APHCAL register.

APHCAL =

$$\begin{cases} Error(^{\circ}) \leq 0, \Rightarrow APHCAL = PhaseCompensation \\ Error(^{\circ}) > 0, \Rightarrow APHCAL = PhaseCompensation + 512 \end{cases}$$

For example, at 220 V and 10 A at a power factor of 0.5, if the total active power CFx output frequency is 0.0.9709 Hz and the fundamental only reactive power CFx output frequency is 1.7347 Hz:

$$Error(^{\circ}) = \tan^{-1} \left(\frac{0.9709 \sin(60) - 1.7347 \cos(60)}{1.7347 \sin(60) + 0.9709 \cos(60)} \right) = -0.76^{\circ}$$

Assuming that the line frequency is 50 Hz, the APHCAL compensation can be determined as

PhaseCompensation =

$$\text{abs} \left[\left(\frac{-0.76}{360^{\circ} \times 50} \right) \times 1.024 \text{ MHz} \right] = 0 \times 2B$$

APHCAL = PhaseCompensation = 0 × 2B

Depending on the current sensors being used on Phases A, B and C, different phase calibration values may be required in APHCAL and BPHCAL.

Gain Calibration

Table 8. xPGAIN

Calibration Registers	Address
APGAIN	0x4389
BPGAIN	0x438B
CPGAIN	0x438D

The purpose of the energy gain calibration is to compensate for small gain errors due to part-to-part variation in the internal reference voltage and external components, such as the time error introduced by the crystal. Gain calibration is required on every meter and is performed with nominal voltage and current inputs at a power factor of 0.5. The total active, fundamental active, and reactive power as well as the apparent power are internally gain matched. One single gain calibration step is therefore required to calibrate all powers on a single phase. This section describes calibrating the gain using the total active energy; however, any of the other energy values can be output on the CFx output for calibration.

As discussed in the Table 6, the expected CF output is determined from the meter constant. The actual CF output is measured and the APGAIN register is used to adjust any error. The following formula describes this relationship:

$$APGAIN = 2^{23} \times \left[\frac{CF_{EXPECTED}}{CF_{ACTUAL}} - 1 \right]$$

Using the previous example, at 220 V and 10 A, the expected CF is 0.97778 Hz. Assuming the actually measured CF is 0.9937 Hz, the APGAIN is calculated as

$$APGAIN = 2^{23} \times \left[\frac{0.97778}{0.9937} - 1 \right] = 0x\text{FDF3B0}$$

The BPGAIN and CPGAIN registers control the gain calibration for Phase B and Phase C, respectively. Assuming that the channels are correctly matched, as described in the Gain Matching section, the previous procedure does not need to be repeated for Phase B or Phase C. Write the value calculated for APGAIN to BPGAIN and CPGAIN for accurate results. The fundamental only reactive energy and the apparent energy are also effected by the xPGAIN calibration. Since all power calculations are internally gain matched, setting the xPGAIN registers will gain calibrate all energy measurements.

Total and Fundamental Only Active Energy Offset Calibration (Optional)

Table 9. xWATTOS

Calibration Registers	Address
AWATTOS	0x438A
BWATTOS	0x438C
CWATTOS	0x438E
AFWATTOS	0x43A2
BFWATTOS	0x43A3
CFWATTOS	0x43A4

Active energy offset calibration is only required if accuracy at low loads is outside the required specification prior to offset calibration.

To correct for any voltage-to-current channel crosstalk that may degrade the accuracy of the measurements at low current levels, perform an active energy offset calibration. Apply the minimum expected current signal to allow the offset magnitude to be

measured and then removed. Do not perform offset calibration with grounded inputs because a low level signal is necessary to accurately measure the offset.

In this example, an input current of 100 mA is applied to perform the offset calibration. With a voltage channel input of 220 V at a power factor of 1, the expected CFx output frequency is determined as

$$CF_{EXPECTED} = \frac{3200 \text{ imp/kWh} \times 220 \text{ V} \times 0.1\text{A}/1000 \times \cos(0)}{3600\text{s/h}}$$

$$= 0.0195556\text{Hz}$$

If the actual CF frequency is 0.01947 Hz, the percentage error due to offset is determined as

$$\%Error = \frac{0.01947 - 0.0195556}{0.0195556} = -0.4377\%$$

The offset in the watt measurement is corrected according to the following equation:

$$AWATTOS = -\%Error \times CF_{EXPECTED} \times CFxDEN \times \frac{Threshold}{8 \text{ kHz} \times 128}$$

where *Threshold* is made up of the value in the 8-bit WTHR register joined to an internal 27 bits equal to 0.

If the WTHR is set to the default value of 3h, the threshold value would, therefore, be 18000000h.

$$AWATTOS = -0.004377 \times 0.0195556 \times 0\text{xDB3} \times \frac{0\text{x18000000}}{8 \text{ kHz} \times 128}$$

$$= 0\text{x76}$$

The AFWATTOS register effects the fundamental only active energy offset in the same way as the AWATTOS register effects the total active energy offset. Typically, the same value that was calculated for the AWATTOS can be written to the AFWATTOS for accurate calculations.

Depending on the board layout and the crosstalk on the meter design, Phase B and Phase C may need separate offset calibration. This can be achieved through the BWATTOS and BFWATTOS registers for Phase B, and the CWATTOS and CFWATTOS registers for Phase C.

Reactive Energy Offset Calibration (Optional)

Typically, the value calculated for the xWATTOS register can be used in the xVAROS register for accurate results.

Table 10. xFVAROS

Calibration Registers	Address
AFVAROS	0x43A5
BFVAROS	0x43A6
CFVAROS	0x43A7

Fundamental only reactive energy offset calibration is only required if accuracy at low loads is outside the required specification prior to offset calibration.

To correct for any voltage-to-current channel crosstalk that may degrade the accuracy of the measurements at low current levels, perform a fundamental only reactive energy offset calibration. A low level current signal at a power factor of 0 must be applied to allow the offset magnitude to be measured and then removed.

Similar to the total and fundamental active energy, the fundamental only reactive energy offset is corrected according to the following equation:

$$AFVAROS = -\%Error \times VARCF_{EXPECTED} \times CFxDEN \times \frac{Threshold}{8 \text{ kHz} \times 128}$$

where *Threshold* is made up of the value in the 8-bit WTHR register joined to an internal 27 bits equal to 0. If the WTHR is set to the default value of 3h, the threshold value would, therefore, be 18000000h.

Depending on the board layout and the crosstalk on the meter design, Phase B and Phase C may need separate offset calibration. This can be achieved through the BFVAROS and CVAROS registers, respectively. BFVAROS and CFVAROS correct the Phase B and Phase C fundamental only reactive energy CF output in the same way that the AFVAROS affects the Channel A fundamental only reactive energy CF output.

Harmonic Offset Calibration

Calibration of individual harmonic measurement is not required to achieve the specified accuracy.

CURRENT AND VOLTAGE RMS

Calibrating the voltage and current rms is only required if the instantaneous rms readings are required. Perform the rms calibration using the instantaneous rms register readings. The current readings can be obtained from the AIRMS register, the BIRMS register, and the CIRMS register. The voltage readings can be obtained from the AVRMS register, the BVRMS register, and the CVRMS register. The CFx pulse output is not used for this calibration. For increased stability, synchronize the rms register readings to the ZX measurement. This reduces the effects of ripple in the readings caused by nonidealities of the internal filtering. See the [ADE7880](#) data sheet for details on zero crossing detection.

RMS Gain

Assuming that the channel matching has been performed as described in the Gain Matching section, no further gain calibration should be required on the xIRMS or xVRMS measurement. The readings from the xIRMS and xVRMS registers can be converted into current and voltage values in amps and volts using the V/LSB and Amps/LSB constants. This procedure is performed by the microcontroller and the resulting constants must be saved in the microcontroller. These constants can be calculated using the following formulas:

$$V \text{ Constant [V/LSB]} = \frac{\text{Voltage Input [V]}}{\text{VRMS[LSBs]}}$$

$$I \text{ Constant[Amps/LSB]} = \frac{\text{Current Input[A]}}{\text{IRMS[LSBs]}}$$

Since all phases on all meters are matched, the same constant can be used for all current rms and voltage rms readings on all meters. This constant should be stored in the microcontroller. If this constant is not convenient for storing or a different constant is required, then the xIGAIN and xVGAIN registers can be used to adjust the constant.

$$xVGAIN = \frac{\text{Voltage Input[V]} \times 2^{23}}{V \text{ Constant[Volts/LSB]} \times xVRMS[LSBs]}$$

$$xIGAIN = \frac{\text{Current Input[I]} \times 2^{23}}{I \text{ Constant[Amps/LSB]} \times xIRMS[LSBs]}$$

Note that any adjustment to the xIGAIN register and the xVGAIN register affect all measurements, including the active and reactive powers. Therefore, any adjustments to the xIGAIN or xVAGIN register should be done prior to calibrating the energy.

RMS Offset

Table 11. xRMSOS

Calibration Registers	Address
AIRMSOS	0x438F
AVRMSOS	0x4390
BIRMSOS	0x4391
BVRMSOS	0x4392
CIRMSOS	0x4393
CVRMSOS	0x4394

To obtain accurate readings at low signal levels, the current and voltage rms offset may have to be calibrated. This calibration is done using the internal xVRMSOS and xIRMSOS registers that apply an offset prior to the square root function. The compensation factor is determined by applying the following equations:

$$xVRMSOS = \frac{xVRMS_{EXPECTED}^2 - xVRMS_{ACTUAL}^2}{128}$$

$$xIRMSOS = \frac{xIRMS_{EXPECTED}^2 - xIRMS_{ACTUAL}^2}{128}$$

As illustrated in Figure 7, the rms offset calibration is based on two points, where the expected reading is derived from the rms measurement with nominal inputs.

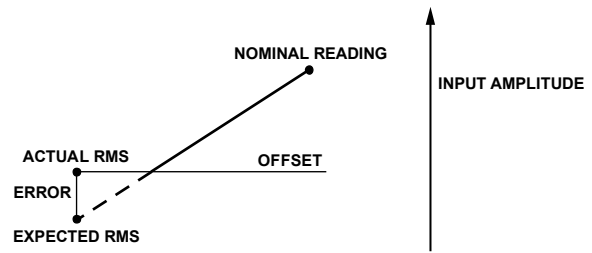

Figure 7. RMS Reading

The rms measurements are specified over a dynamic range of 1000:1. This is the minimum input level at which the measurement is accurate and, thus, the minimum point at which the offset calibration should take place. In this example, the voltage rms offset is calibrated at 22 V, and the current rms offset is calibrated at 100 mA. To determine the expected rms reading, take a measurement at the nominal current and the nominal voltage. This reading should then be scaled down to obtain the expected value at the calibration point.

For example:

Reading at $I_{NOMINAL}$ (10 A) = 613390

Expected reading at I_{CAL} (100 mA) = $(0.1/10) \times 613390 = 6134$

Actual reading obtained at I_{CAL} (100 mA) = 6349

Therefore,

$$IRMSOS = \frac{6134^2 - 6349^2}{128} = 0xFFAE18$$

The voltage rms offset is calibrated in a similar manner.

For example:

Reading at $V_{NOMINAL}$ (220 V) = 2273500

Expected reading at V_{CAL} (22 V) = $(22/220) \times 2273500 = 227350$

Actual reading obtained at V_{CAL} (22 V) = 226595

Therefore,

$$VRMSOS = \frac{227350^2 - 226595^2}{128} = 0x28DB3E$$

CALIBRATING USING THE ENERGY REGISTERS

This section explains the calibration procedure and calculations when using the internal energy registers. The internal energy registers provide access energy metering measurements via the SPI or I²C interface (see the [ADE7880](#) data sheet for more details).

If calibrating using the internal energy registers, use an accurate source. Calibration via the internal registers is typically performed when the CF pulse is not required in the final meter design. Figure 1 shows the relationship between the CF output and energy registers. Figure 8 shows the calibration flow for the energy measurements. Use this flowchart to determine a calibration routine.

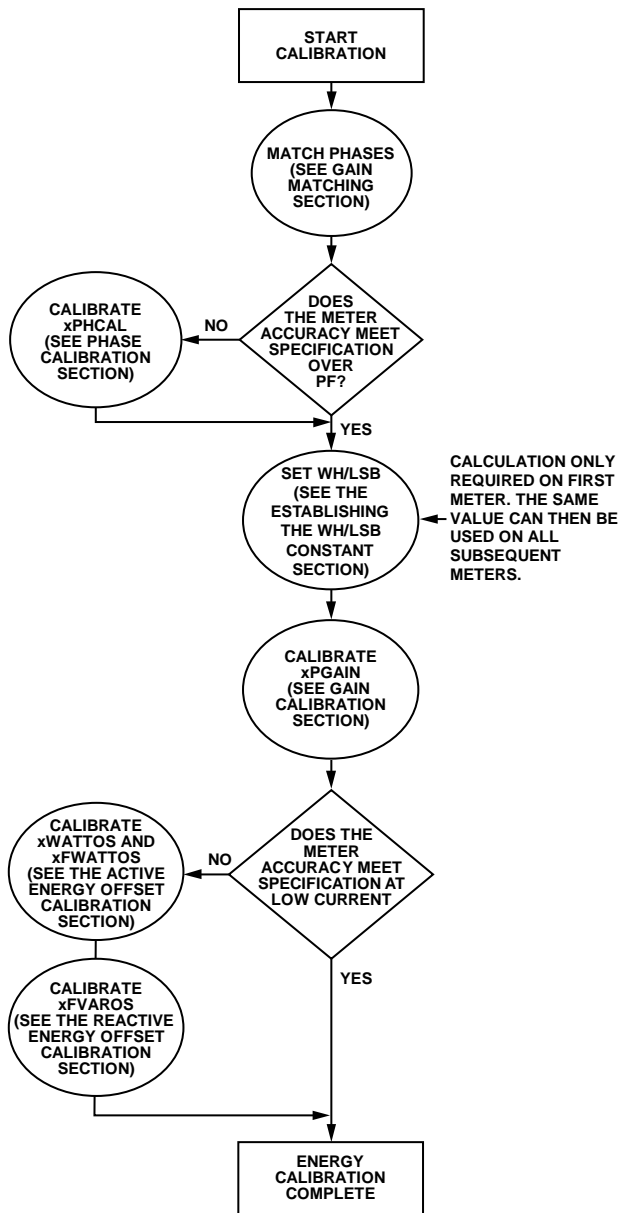

Figure 8. Active Energy Calibration Flow

GAIN MATCHING

It is convenient to match all three phases prior to calibrating. Matching the phases results in easier computations because one bit in the energy has the same weight on each phase. It is recommended to perform phase matching as the first calibration step. See the Gain Matching section for details on matching the phases.

PHASE CALIBRATION (OPTIONAL)

Table 12. xPHCAL

Calibration Registers	Address
APHCAL	0xE614
BPHCAL	0xE615
CPHCAL	0xE616

Phase calibration is required when the sensor currently being used introduces a phase shift. CTs can add significant phase shift that introduces large errors at low power factors. Phase calibration should be performed before gain or offset calibration because large phase corrections can alter the gain response of the [ADE7880](#).

Phase calibration can be performed with a single inductive or capacitive load at a power factor of 0.5. If this load is not available, another power factor can be chosen; however, for best results, the power factor should be as close to 0.5 as possible. The following equation outlines how to determine the phase error in degree where ϕ refers to the angle between the voltage and the current (in degrees).

$$Error(^{\circ}) = \tan^{-1} \left(\frac{AWATTHR \sin(\phi) - AVARHR \cos(\phi)}{AVARHR \sin(\phi) + AWATTHR \cos(\phi)} \right)$$

where:

ϕ refers to the angle between the voltage and the current (in degrees).

Once the error in degrees is determined, the following formula can be used to determine the required phase compensation:

$$PhaseResolution = \left(\frac{360^{\circ} \times f}{1.024 \text{ MHz}} \right)$$

$$PhaseCompensation = \text{abs} \left(\frac{Error(^{\circ})}{PhaseResolution} \right)$$

where:

f refers to the line frequency.

Note that the format of the APHCAL register is such that if the value of the Error(degrees) is positive, then a value of 512d must be added to the calculated PhaseCompensation prior to writing to the APHCAL register.

11090-008

$$APHCAL = \begin{cases} Error(^{\circ}) \leq 0, \Rightarrow APHCAL = PhaseCompensation \\ Error(^{\circ}) > 0, \Rightarrow APHCAL = PhaseCompensation + 512 \end{cases}$$

For example, if, at 220 V and 10 A at a power factor of 0.5, the AWATTHR value is 3384 and the AVARHR is 5663, the error in degrees can be calculated as follows:

$$Error(^{\circ}) = \tan^{-1} \left(\frac{3384 \sin(60) - 5663 \cos(60)}{5663 \sin(60) + 3384 \cos(60)} \right) = +0.86^{\circ}$$

Assuming the line frequency is 50 Hz, the APHCAL compensation can be determined as:

$$PhaseCompensation = abs \left[\left(\frac{+0.86}{360^{\circ} \times 50} \right) \times 1.024 MHz \right] = 0 \times 31$$

$$APHCAL = PhaseCompensation + 512 = 0 \times 231$$

Depending on the current sensors being used on Phases A, B, and C, different phase calibration values may be required in APHCAL, BPHCAL and CPHCAL.

Establishing the Wh/LSB Constant—First Meter Only

When calibrating the first meter, the Wh/LSB must be determined. The Wh/LSB constant is used to set the weighting of each LSB in the active energy register. This constant allows the energy register readings to be converted into real world values.

Once established, the same Wh/LSB meter can be used for each subsequent meter. The weighting of each LSB in the energy register is often stated in the specifications of the design. If no specification is provided, then the user can select the weighting. To determine the Wh/LSB constant, the following formula can be used:

$$Wh / LSB = \frac{Load(W) \times AccumulationTime(sec)}{xWATTHR \times 3600}$$

where:

AccumulationTime is the line cycle accumulation time.

xWATTHR is the energy register reading after this time has elapsed.

For example, if a line cycle value of 100 has been set and the frequency of the input signal is 50 Hz, the accumulation time will be 1 second ($0.5 \times (1/50) \times 100$) assuming that only one phase is selected for the zero crossing detection (LCYCMODE bits 4:6). With a load of 220 V and 10 A with a power factor of 0.5, this produces an AWATTHR reading of 3299. The Wh/LSB constant can be calculated as follows:

$$Wh / LSB = \frac{220 V \times 10 A \times \cos(60) \times 1 sec}{3299 \times 3600} = 9.6262 \times 10^{-5}$$

Should the user wish to adjust the constant to meet a particular specification or make the constant a rounder number for storing purposes, the APGAIN register can be used. The APGAIN register can be used to modify the Wh/LSB constant

by $\pm 100\%$. The APGAIN register affects the AWATTHR register as shown in the following formula:

$$APGAIN = 2^{23} \times \left[\frac{AWATTHR_{Expected}}{AWATTHR_{Actual}} - 1 \right]$$

To achieve a different meter constant, the AWATTHR reading must be altered based on the desired Wh/LSB.

$$AWATTHR_{Expected} = \frac{Load(W) \times AccumulationTime(sec)}{Wh / LSB \times 3600}$$

For example, to alter the previously calculated Wh/LSB constant of 9.6262×10^{-5} to 9×10^{-5} for storing purposes, the desired AWATTHR reading is

$$AWATTHR_{Expected} = \frac{220 V \times 10 A \times \cos(60) \times 1 sec}{9 \times 10^{-5} \times 3600} = 3395d$$

The required PWGAIN value is then

$$APGAIN = 2^{23} \times \left[\frac{3395}{3299} - 1 \right] = 0x3AF52$$

ENERGY GAIN CALIBRATION

Table 13. xPGAIN

Calibration Registers	Address
APGAIN	0x4389
BPGAIN	0x438B
CPGAIN	0x438D

The purpose of the active energy gain calibration is to compensate for small gain errors due to part-to-part variation in the internal reference voltage and external components, such as the time error introduced by the crystal. Gain calibration is required on every meter and is performed with nominal voltage and current inputs at a power factor of 0.5. The total active, fundamental active and reactive power and the apparent power are internally gain matched. One single gain calibration step is thus required to calibrate all powers on a single phase.

For simplicity, it is recommended that all meters be calibrated to use the same Wh/LSB value, and this should be set up in the first meter as explained in the Establishing the Wh/LSB Constant—First Meter Only section. Use the following formula to determine the expected reading in the AWATTHR register:

$$AWATTHR_{EXPECTED} = \frac{Load(W) \times AccumulationTime(sec)}{Wh / LSB \times 3600s / h}$$

The actual value can then be read from the AWATTHR register and the APGAIN register can be used to correct any error. The following formula shows how APGAIN can be used to adjust the AWATTHR reading:

$$APGAIN = 2^{23} \times \left[\frac{AWATTHR_{EXPECTED}}{AWATTHR_{ACTUAL}} - 1 \right]$$

Using the previous example, at 220 V and 10 A, the expected AWATTHR reading is 3395d. Assuming that the actual AWATTHR reading is 3380d, APGAIN is calculated as

$$AWGAIN = 2^{23} \times \left[\frac{3395}{3380} - 1 \right] = 0x916C$$

Note that the gain calibration for Phase B and Phase C is controlled by the BPGAIN and CPGAIN registers, respectively. Assuming that the channels are correctly matched, as described in the Gain Matching section, the previous procedure does not need to be repeated for the other channels.

Write the value calculated for APGAIN to BPGAIN and CWGAIN for accurate results. Since all power calculations are internally gain matched, setting the xPGAIN registers gain calibrate all energy measurements.

Total and Fundamental Only Active Energy Offset Calibration (Optional)

Table 14. xWATTOS

Calibration Registers	Address
AWATTOS	0x438A
BWATTOS	0x438C
CWATTOS	0x438E
AFWATTOS	0x43A2
BFWATTOS	0x43A3
CFWATTOS	0x43A4

Total and fundamental only active energy offset calibration is only required if accuracy at low loads is outside the required specification prior to offset calibration.

To correct for any voltage-to-current channel crosstalk that may degrade the accuracy of the measurements at low current levels, perform active energy offset calibration. A low level current signal must be applied to allow the offset magnitude to be measured and then removed.

When performing offset calibration, it is often required to increase the accumulation time to minimize the resolution error. As the line-cycle accumulation mode accumulates energy over a fixed time, the result is accurate to ± 1 LSB. If the number of bits accumulated in the xWATTHR register is small after this time, the ± 1 LSB error can result in a large error in the output. For example, if only 10 bits are accumulated in the xWATTHR register, the resolution error is 10%. Increasing the number of accumulation bits to 1000 reduces the resolution error to 0.1%.

In the following example, a LINECYC of 5000 half line cycles is set, and an input current of 100 mA is applied. With a voltage channel input of 220 V at a power factor of 1, the expected AWATTHR reading is determined as

$$AWATTHR_{EXPECTED} = \frac{220 \text{ V} \times 0.1 \text{ A} \times \cos(0) \times 50 \text{ sec}}{9 \times 10^{-5} \times 3600} = 3395$$

If the actual AWATTHR register reading is 3380 at 100 mA, the percentage error due to offset is determined as

$$\%Error = \frac{3380 - 3395}{3395} = -0.44\%$$

The offset in the watt measurement is corrected according to

$$AWATTOS = -\%Error \times \frac{AWATTHR_{EXPECTED}}{AccumulationTime(sec)} \times \frac{Threshold}{8 \text{ kHz} \times 128}$$

where:

Threshold is made up of the value in the 8-bit WTHR register joined to an internal 27 bits equal to 0. If the WTHR is set to the default value of 3h, the threshold value would, therefore, be 18000000h.

$$AWATTOS = 0.0044 \times \frac{3395}{50} \times \frac{0x18000000}{8 \text{ kHz} \times 128} = 0x76$$

The AFWATTOS register effects the fundamental only active energy offset in the same way as the AWATTOS register effects the total active energy offset.

Depending on the board layout and the crosstalk on the meter design, Phase B and Phase C may need separate offset calibration. This can be achieved through the BWATTOS and BFWATTOS registers for Phase B, and the CWATTOS and CFWATTOS registers for Phase C.

Fundamental Only Reactive Energy Offset Calibration

Table 15. xFVAROS

Calibration Registers	Address
AFVAROS	0x43A5
BFVAROS	0x43A6
CFVAROS	0x43A7

Fundamental only reactive energy offset calibration is only required if accuracy at low loads is outside the required specification prior to offset calibration.

To correct for any voltage-to-current channel crosstalk that may degrade the accuracy of the measurements at low current levels, reactive energy offset calibration is performed. A low level current signal must be applied to allow the offset magnitude to be measured and then removed.

When performing offset calibration, it is often required to increase the accumulation time to minimize the resolution error. Because the line-cycle accumulation mode accumulates energy over a fixed time, the result is accurate to ± 1 LSB. If the number of bits accumulated in the xVARHR register is small after this time, the ± 1 LSB error can result in a large error in the output.

For example, if only 10 bits are accumulated in the xVARHR register, the resolution error is 10%. Increasing the number of accumulation bits to 1000 reduces the resolution error to 0.1%. The expected xVARHR reading is determined as

$$A_{VARHR}_{EXPECTED} = \frac{Load (VAR) \times Accumulation Time (sec)}{VARhr / LSB \times 3600 s/h}$$

The offset in the reactive energy measurement is corrected according to the following equations:

$$A_{VAROS} = -\%Error \times \frac{A_{FVARHR}_{EXPECTED}}{Accumulation Time (sec)} \times \frac{Threshold}{8 \text{ kHz} \times 128}$$

where:

Threshold is made up of the value in the 8-bit WTHR register joined to an internal 27 bits equal to 0.

If the WTHR is set to the default value of 3h, the threshold value would therefore be 18000000h.

Note that, depending on the board layout and the crosstalk on the meter design, Phase B and Phase C may need a separate offset calibration. This can be achieved through the BFCVAROS and CFVAROS registers. These registers correct the respective xVARTHR register reading in the same way that AFVAROS affects the AWATTHR register reading.

Harmonic Offset Calibration

Calibration of individual harmonic measurement is not required to achieve the specified accuracy.

CURRENT AND VOLTAGE RMS

Calibrating the voltage and current rms is only required if the instantaneous rms readings are required. Perform the rms calibration using the instantaneous rms register readings. See the Current and Voltage RMS section for full details on calibrating the current and voltage rms.

NOTES