

Embedding Temperature Information in the ADXL202's PWM Outputs

by Harvey Weinberg

INTRODUCTION

Many cases exist where it's important to know the temperature of the ADXL202. Sometimes temperature information is necessary for control or data logging requirements (as in data loggers used to monitor how articles are handled in shipping) or for high precision tilt sensor applications (for temperature compensation of the zero g drift of the accelerometer). Since no A/D converter is required when using the ADXL202's duty cycle outputs, it is preferable to have some means of acquiring temperature information digitally.

This application note outlines a simple method of embedding the temperature information from a TMP36 voltage output temperature sensor in the duty cycle acceleration output of the ADXL202. No A/D converter is required, and no additional I/O is necessary.

BASIC PRINCIPLE OF OPERATION

The duty cycle output period is proportional to the current flowing through R_{SET} . The voltage at the T2 Pin is typically 1.25 V. So for the recommended range of the R_{SET} resistor (125 k Ω to 1.25 M Ω) the current is 1 μ A to 10 μ A. Normally R_{SET} is connected between the T2 Pin and ground, but any noise free voltage source between 0 V and 1.25 V is acceptable.

In Figure 1, a TMP36 voltage output temperature sensor is connected to R_{SET} . The TMP36 has an output voltage of:

$$0.75 + (0.01 \times T) \text{ Volts}$$

where T = temperature in $^{\circ}$ C.

Over a range of -40° C to $+70^{\circ}$ C, the output is 0.1 V to 1.2 V. The resulting current is:

$$I_{R_{SET}} = \frac{1.25 - V_R}{R_{SET}} = \frac{1.25}{R_{SET}} - (V_R - R_{SET})$$

Using a 125 k Ω resistor for R_{SET} , the current is 9.2 μ A to 0.4 μ A over the -40° C to $+70^{\circ}$ C temperature range.

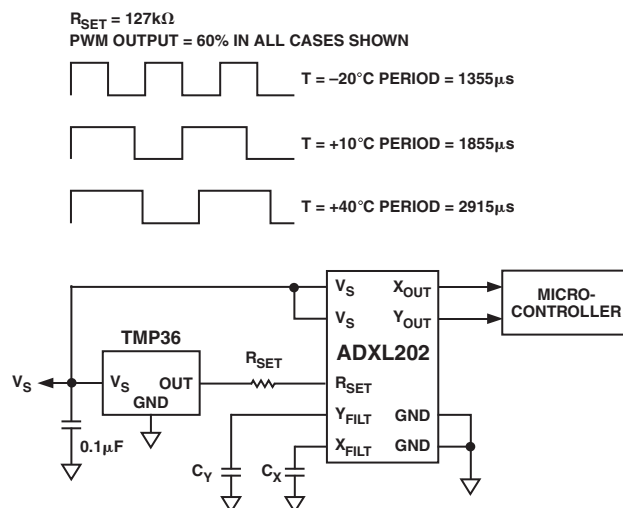

Figure 1. Using a Temperature Sensor to Embed Temperature Information into the Acceleration Duty Cycle Output of the ADXL202

In most applications, the period need not be measured every cycle (this is discussed thoroughly in the "Using the ADXL202 Duty Cycle Output" application note). Since temperature change is normally a low speed phenomenon, this will not affect the accuracy of the temperature measurements. Measuring the period a few times per second should be more than sufficient.

A subroutine used to determine the temperature from the T2 period must be added to the user's firmware. Since the change in T2 is not completely linear over temperature, the subroutine's complexity will vary in proportion to the temperature accuracy required. Table I shows the typical T2 period versus temperature. Using a simple calculation of:

$$\text{Temperature} = \frac{1735 - T2}{26}$$

where *Temperature* is in $^{\circ}$ C and $T2$ is in μ s. This technique will result in temperature readings that are accurate to $\pm 5.5^{\circ}$ C over a range of -20° C to $+40^{\circ}$ C. If more accurate

AN-600

temperature readings are required, a simple look-up table can be used. Alternatively, both the initial constant (1735) and the divisor (26) may be modified for higher accuracy over a narrower temperature range.

Table I. T2 vs. Temperature for the Circuit in Figure 1

Temp. (°C)	T2 (μs)	Calculated Temp.
-30	1250	-18.7
-25	1300	-16.7
-20	1355	-14.5
-15	1420	-12.1
-10	1490	-9.4
-5	1565	-6.5
0	1650	-3.3
+5	1740	+0.2
+10	1855	+4.5
+15	1980	+9.5
+20	2110	+14.4
+25	2280	+21
+30	2450	+27.5
+35	2660	+35.6
+40	2915	+45.5
+45	3230	+57.5
+50	3620	+72.5

For example, consider a shipping conditions recorder for an item that must be kept at 10°C ± 1°C. From Table I we see that 10°C produces a T2 period of 1855 μs. Assuming that we are interested in high accuracy over the 5°C to 15°C range, we see that the T2 period changes from 1980 μs at 15°C to 1740 μs at 5°C. Therefore we can assume that the T2 change per °C is:

$$\frac{1980 - 1740}{15^{\circ}\text{C} - 5^{\circ}\text{C}} = 24 \mu\text{s}/^{\circ}\text{C}$$

We can then modify our temperature equation to:

$$\text{Temperature} = \frac{T2 - 1855}{24} + 10$$

in °C, which will be accurate to ±0.2°C over the 5°C to 15°C range.

E03045-0-7/02(0)

PRINTED IN U.S.A.