

Troubleshooting the MAX38640A (1.8V Output) SMPS Circuit

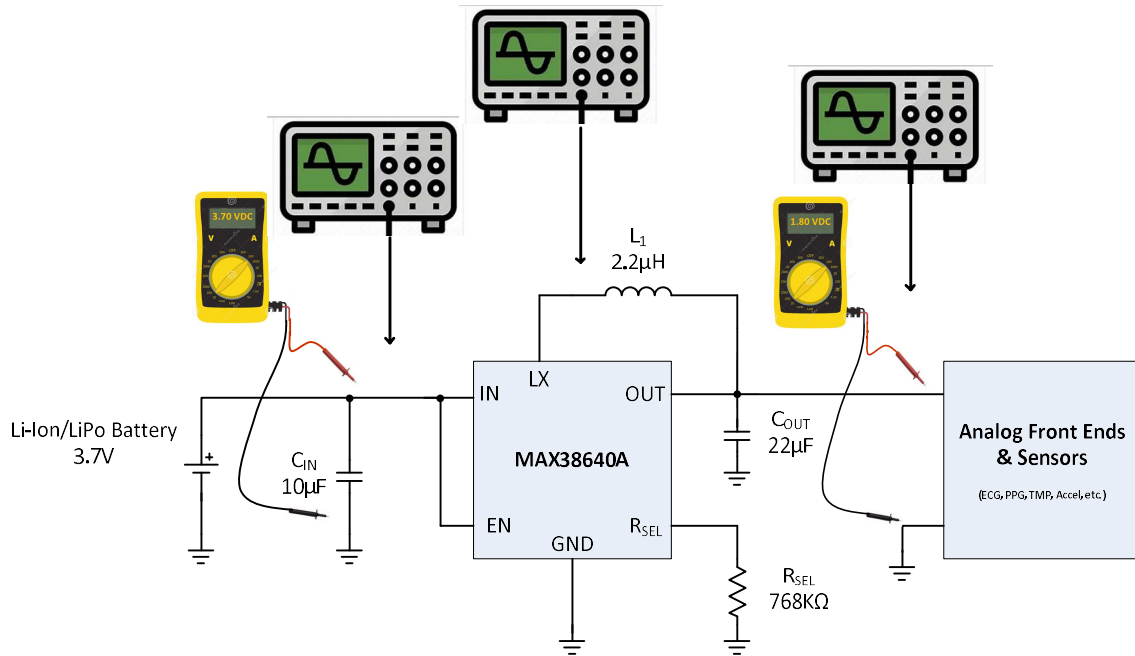

Figure1: Troubleshooting the MAX38640A SMPS Circuit

Troubleshooting the MAX38640A SMPS Circuit:

Step 1 – Check the Input Voltage: Using a digital multimeter (DMM) with an internal impedance of a 1Mohm or larger (e.g., Fluke 87), measure the voltage across at the input to the MAX38640A device. Be sure to connect the negative “black” lead to ground and the positive “red” lead to the input “IN” pin of the device. If the input pin is not easily assessable, place the leads across the input capacitor, C_{IN} .

Use the following table to diagnose and fix associated problems:

Input Voltage Reading	Potential Cause	Action	Notes
Zero Volts/No Reading	Battery uncharged. Battery defective.	Disconnect battery and check voltage. If it reads 0V, recharge battery.	Replace battery if it doesn't charge.
	No connection from battery (IN or GND line)	Disconnect battery and test for conductivity from battery connector to device input.	PCB may have an open.
	Input capacitor shorted to ground	Disconnect battery and check for continuity across capacitor.	Bad capacitor; PCB may have short.

	EN pin connected to ground	Disconnect battery and test for conductivity from EN pin to ground .	EN pin needs to be tied high for normal operation.
Reading < 2.8V	Low battery charge Battery defective	Disconnect battery and check voltage. If it reads below 2.8V, recharge battery.	Replace battery if it doesn't charge.
$2.8V \geq \text{Reading} \leq 4.2V$		No action.	Input voltage OK, proceed to step 2.
Reading $\geq 4.2V$	Defective battery	Replace battery.	

Step 2 – Check the Inductor Signal Waveform: Using an oscilloscope or digital storage scope (DSO), probe the LX pin on the MAX38640A device. If the input pin is not easily assessable, place the probe on the inductor end cap.

If the circuit is operating correctly with a light load (i.e., less than 50mA), the waveform should appear as shown in the following figure:



Figure 2: Typical MAX38640A VLX Waveform with Light Load

If the circuit is operating correctly with a heavy load, the waveform should be a square wave with minimal ringing on the rise and falling edges as shown in the following figure:

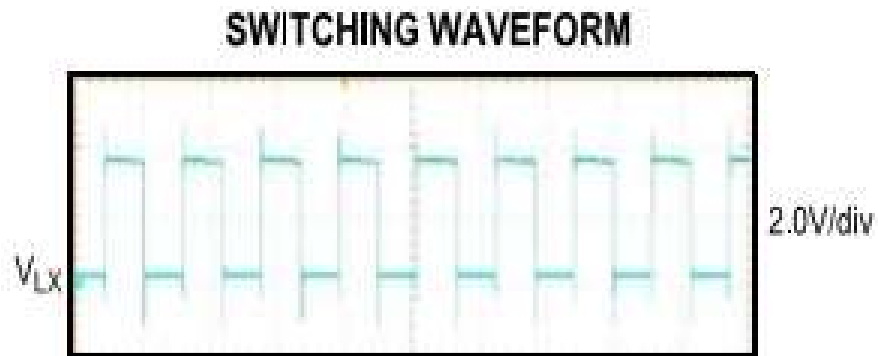

Figure 3: Typical MAX38640A VLX Waveform

The square wave amplitude should be approximately equal to the input battery voltage. The square wave floor voltage should be about 200-300mV below ground (e.g., -250mV). The duty cycle is proportional to the output voltage. Thus, a 3.6V input battery voltage will have an approximate 50% duty cycle when producing an output voltage of 1.8V. The figure below shows the relationship between the duty cycle and output voltage.

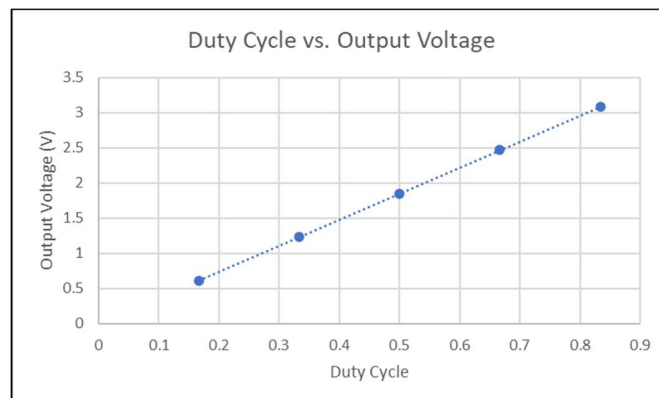

Figure 4: MAX38640A Duty Cycle Vs. Output Voltage

Deviations from the ideal square wave can be used to effectively diagnose and fix many problems.

Use the following table to diagnose and fix associated problems:

Input Waveform	Potential Cause	Action	Notes
Amplitude is not correct	Inductor open. IN pin open EN is open or ground	Disconnect battery and check all connections with DMM.	Repair PCB if needed.
Duty Cycle is not correct (Doesn't correlate to the output voltage)	R _{SEL} is not the correct value (768K Ω). Bad external resistor.	Disconnect battery and check R _{SEL} with a DMM (R-measurement)	Replace resistor with correct value resistor.
	R _{SEL} pin open (Vo = 2.5V).	Check output for 2.5V. Disconnect battery and test for conductivity from resistor to R _{SEL} pin.	PCB may have an open.
	R _{SEL} pin shorted to ground (Vo=0.8V)	Check output for 0.8V. Disconnect battery and measure resistance across capacitor.	PCB may have short.
Waveform distortion Rounded rising edge	Bad inductor connection	Re-connect inductor. Replace inductor.	Bad connection can cause higher line resistance

Step 3A – Check the Output DC Voltage: Using a digital multimeter (DMM) with an internal impedance of a 1Mohm or larger (e.g., Fluke 87), measure the voltage at the output of the MAX38640A device. Be sure to connect the negative “black” lead to ground and the positive “red” lead to the output “OUT” pin of the device. If the output pin is not easily assessable, place the leads across the output capacitor, C_{OUT}.

Use the following table to diagnose and fix associated problems:

Output Voltage Reading	Potential Cause	Action	Notes
Zero Volts/No Reading	No connection from SMPS to C _{OUT}	Disconnect battery and test for conductivity from output to C _{OUT}	PCB may have an open.
	Output capacitor shorted to ground	Disconnect battery and check for continuity across capacitor.	PCB may have short.
Reading too low (< 1.71 VDC)	Inductor wrong value Inductor saturated R _{SEL} has wrong value	Disconnect battery and check for inductor and/or resistor values.	
1.71V \geq Reading \leq 1.89		No action.	Operational.
Reading too high (> 1.89 VDC)	R _{SEL} has wrong value	Disconnect battery and check R _{SEL} value.	

Step 3B – Check the Output AC Voltage: Using an oscilloscope or digital storage scope (DSO), we will now measure the output ripple (AC) by probing the OUT pin on the MAX38640A device. To properly measure the output, avoiding RF pickup, it is recommended that a differential technique be employed.

If the circuit is operating correctly, the waveform should be a 1.8VDC output with a small ripple waveform superimposed on it. The ripple waveform should resemble that shown in the following figure:

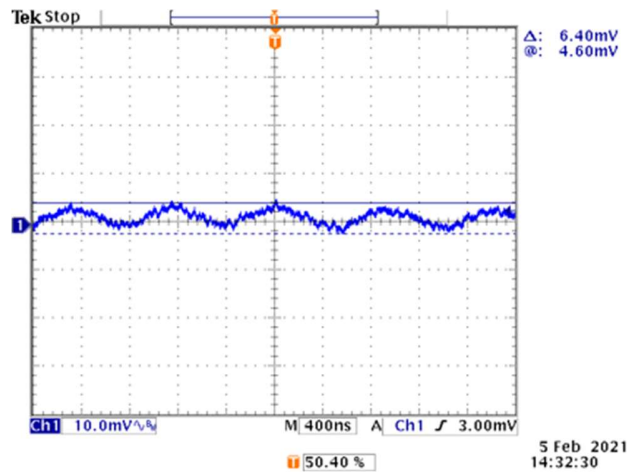

Figure 5: MAX38640A Output Ripple Waveform

Use the following table to diagnose and fix associated problems:

Input Waveform	Potential Cause	Action	Notes
Ripple amplitude is too high (> 20mVpp)	Wrong capacitor value; defective capacitor	Disconnect battery and check all connections with DMM ; Measure capacitor value	
Ripple frequency doesn't match V_{Lx} square wave frequency	Light load	Check load	
Broadband Noise is too high	Load too large; environmental noise.	Check load and environmental noise.	Use differential probing on output to reduce environmental noise.
Transition Spikes too high (> 30mVp)	Load inductance; Input current not adequate	Check line inductance; Check input current with scope.	