

Devices Connected/Referenced

AD7988-1	16-Bit, 100 kSPS PuISAR ADC
AD8641	Low Power, Rail-to-Rail Output Precision Single JFET Op Amp
ADR435	Ultralow Noise XFET® 5.0V Voltage Reference

16-Bit, 100 kSPS, Low Power Data Acquisition System Optimized for Sub-Nyquist Input Signals up to 1 kHz

EVALUATION AND DESIGN SUPPORT

Circuit Evaluation Boards

[CN-0306 Circuit Evaluation Board \(EVAL-CN0306-SDPZ\)](#)
[System Demonstration Platform \(EVAL-SDP-CB1Z\)](#)

Design and Integration Files

[Schematics, Layout Files, Bill of Materials](#)

CIRCUIT FUNCTION AND BENEFITS

The circuit shown in Figure 1 is a 16-bit, 100 kSPS successive approximation analog-to-digital converter (ADC) system that has a drive amplifier that is optimized for a low system power dissipation of 7.35 mW for input signals up to 1 kHz and sampling rates of 100 kSPS.

This approach is highly useful in portable battery powered or multichannel applications, or where power dissipation is critical. It also provides benefits in applications where the ADC is idle most of the time between conversion bursts.

Drive amplifiers for high performance successive approximation ADCs are typically selected to handle a wide range of input frequencies. However, when an application requires a lower sampling rate, considerable power can be saved because reducing the sampling rate reduces the ADC power dissipation proportionally.

To take full advantage of the power saved by reducing the ADC sampling rate, a low bandwidth, low power amplifier is required.

For instance, the 80 MHz [ADA4841-1](#) op amp (12 mW at 10 V) is recommended for operation with the [AD7988-1](#) 16-bit successive approximation register (SAR) ADC (0.7 mW at 100 kSPS). The total system power dissipation including the [ADR435](#) reference (4.65 mW at 7.5 V) is 17.35 mW at 100 kSPS.

For input bandwidths up to 1 kHz and sampling rates of 100 kSPS, the 3 MHz [AD8641](#) op amp (2 mW at 10 V) offers excellent signal-to-noise ratio (SNR) and total harmonic distortion (THD) performance and reduces total system power from 17.35 mW to 7.35 mW, which is a 58% power savings at 100 kSPS.

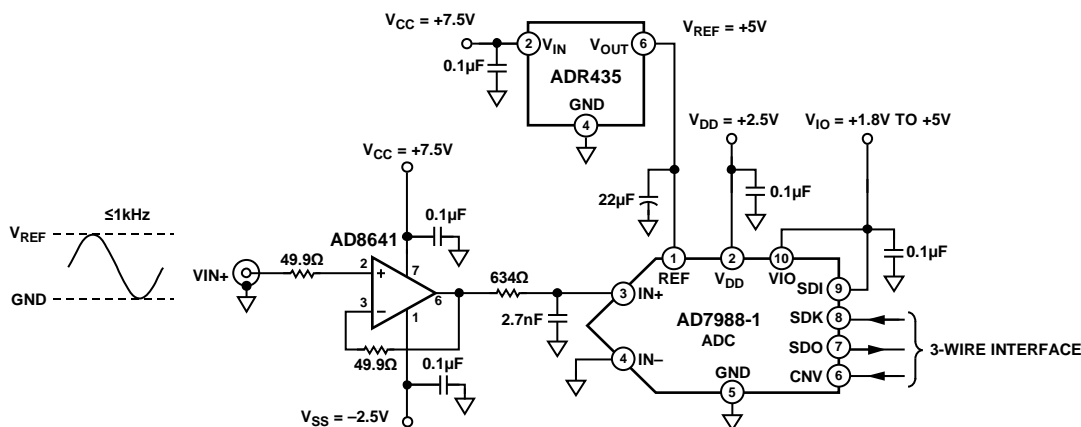

Figure 1. System Circuit Diagram of Low Power [AD8641](#) Amplifier Driving the [AD7988-1](#) ADC (Simplified Schematic: All Connections Not Shown)

Rev. A

Circuits from the Lab® reference designs from Analog Devices have been designed and built by Analog Devices engineers. Standard engineering practices have been employed in the design and construction of each circuit, and their function and performance have been tested and verified in a lab environment at room temperature. However, you are solely responsible for testing the circuit and determining its suitability and applicability for your use and application. Accordingly, in no event shall Analog Devices be liable for direct, indirect, special, incidental, consequential or punitive damages due to any cause whatsoever connected to the use of any Circuits from the Lab circuits. (Continued on last page)

CIRCUIT DESCRIPTION

The circuit comprises the [AD7988-1](#) ADC, [AD8641](#) amplifier, and [ADR435](#) reference. The [AD7988-1](#) is a 16 bit, 100 kSPS SAR ADC whose low power is scalable with sampling rate and consumes 0.7 mW at 100 kSPS. Its low power also comes with industry-leading ac performance: SNR = 91 dB and THD = -114 dBc.

The driving amplifier is the low power precision [AD8641](#) that has a supply current of 200 μ A and a gain bandwidth product of 3 MHz. The [AD8641](#) can be driven with supplies ranging from 5 V to 26 V. The reference for the ADC is the [ADR435](#), which is a high precision, low noise, 5 V XFET voltage reference. The [ADR435](#) has a very low temperature coefficient of 3 ppm/ $^{\circ}$ C at a low supply current of 620 μ A. The total power for this circuit is 7.35 mW at 100 kSPS. The SNR is 88.5 dBFS, and the THD is -103 dBc with an input frequency up to 1 kHz.

The [AD8641](#) is configured as a unity-gain buffer and has an RC filter (634 Ω , 2.7 nF) with a 93 kHz cutoff frequency between it and the [AD7988-1](#). The filter allows the use of a higher noise amplifier such as the [AD8641](#) at 28 nV/ $\sqrt{\text{Hz}}$ while still getting the benefits of much lower power consumption. The tradeoff of higher noise for lower power causes a 2.5 dB reduction in the SNR performance of the system compared to the ADC specification. The higher value of R (634 Ω) relative to the recommended data

sheet value (20 Ω) means the [AD8641](#) can drive the large 2.7 nF input capacitor. The higher R value limits the maximum input bandwidth to 1 kHz for low distortion.

This compares favorably to the 16-bit distortion performance (THD less than -100 dBc) of the [AD8641](#) for up to 1 kHz inputs. Distortion increases beyond 1 kHz so that it is not advisable to use this circuit with higher input frequencies or to use this amplifier in a multiplexed application due to the longer settling time. Note that the [AD8641](#) requires at least 2 V of input headroom with respect to the positive supply voltage. The output stage is rail-to-rail.

Performance Results

The goal of this circuit is to deliver good ac performance at the lowest ADC driver power level possible for a given input frequency range up to 1 kHz and sampling rate of 100 kSPS. Figure 2 shows an FFT plot of the circuit performance with a 1 kHz input signal. An SNR of 88.5 dB, and a THD of -103 dB is achieved. The main reason for the reduction in SNR from the 91 dB specification of the [AD7988-1](#) is the higher noise of the [AD8641](#) of 28 nV/ $\sqrt{\text{Hz}}$ vs. 2 nV/ $\sqrt{\text{Hz}}$ for the [ADA4841-1](#). The total system power is 7.35 mW: 0.7 mW for the ADC, 2 mW for the amplifier, and 4.65 mW for the reference. This represents a 58% reduction in power from using the [ADA4841-1](#), which consumes 12 mW for a total system power of 17.35 mW.

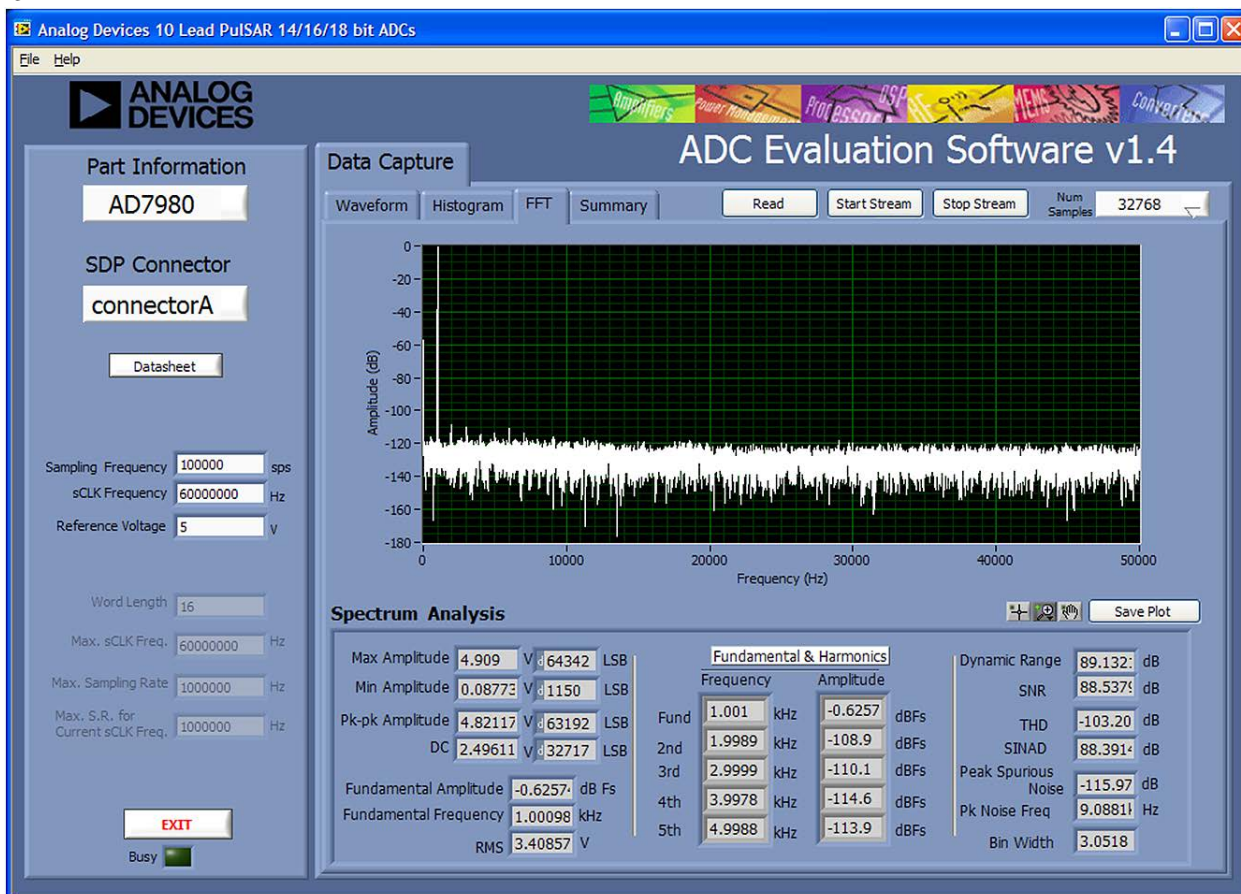

Figure 2. System Circuit Performance with the [AD8641](#) Amplifier Driving the [AD7988-1](#)

Figure 3 shows how the system THD and SNR decrease with input frequencies beyond ~1 kHz. This is due to the amplifier distortion as can be seen in the THD+N vs. frequency plot shown in Figure 4.

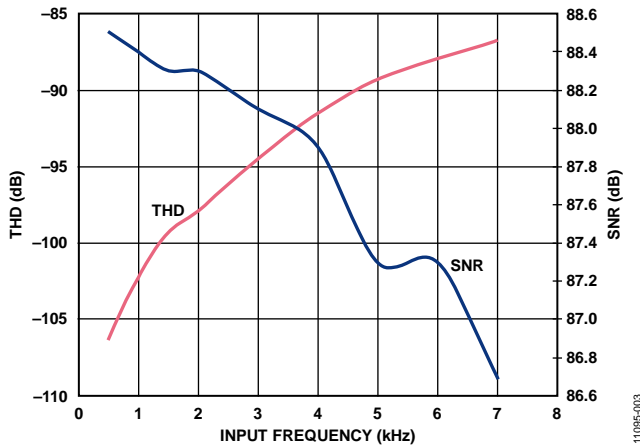

Figure 3. THD and SNR vs. Input Frequency for AD8641 Amplifier Driving the AD7988-1

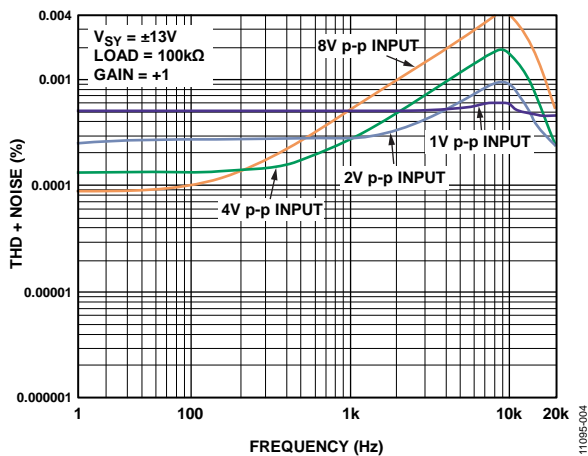

Figure 4. THD+N vs. Input Frequency Performance of the AD8641 Amplifier

COMMON VARIATIONS

The AD8641 amplifier can be used to drive higher speed, pin compatible ADCs like the AD7988-5 and the AD7980 but only at lower sampling rates of up to 100 kSPS. The OP1177 amplifier can be used to drive the AD7988-1 at double the current (400 μ A) with the benefits of improved distortion up to 4 kHz and better system SNR of 90 dB because of its lower noise.

CIRCUIT EVALUATION AND TEST

Equipment Needed (Equivalents Can Be Substituted)

The following equipment is needed:

- The EVAL-CN0306-SDPZ evaluation board
- The System Demonstration Board (EVAL-SDP-CB1Z)
- A function generator/signal source, such as the Audio Precision SYS-2522 used in these tests
- The 9 V wall power supply included with the evaluation board
- A PC with a USB port, a USB cable, and the 10-lead PulSAR software installed

Setup and Test

Install the 10-lead PulSAR software downloadable from the AD7988-1 product page on the Analog Devices website using the installation guide in the UG-340 user guide. The block diagram of the measurement setup is shown in Figure 5.

Connect the 9 V wall power supply to the evaluation board power terminal. To measure the frequency response, connect the equipment as shown in Figure 5. Set the Audio Precision SYS-2522 signal generator for a 1 kHz frequency and a 5 V p-p sine wave with a 2.5 V dc offset. Record the data using the evaluation board software. The software analysis is part of the evaluation board software that allows the user to capture and analyze ac and dc performance. This software and its features are described in UG-340 user guide.

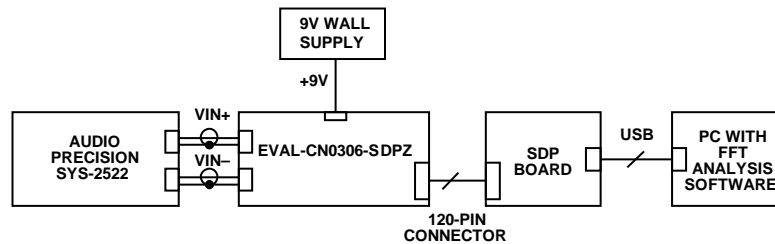

Figure 5. Functional Diagram of Test Setup

LEARN MORE

CN0306 Design Support Package:

<http://www.analog.com/CN0306-DesignSupport>

UG-340 User Guide, *Evaluation Board for the 8-/10-Lead Family of 14-/16-/18-Bit PulSAR ADCs*, Analog Devices.

EVAL-SDP-CB1Z System Demonstration Platform (SDP)

MT-021 Tutorial, *Successive Approximation ADCs*, Analog Devices

MT-031 Tutorial, *Grounding Data Converters and Solving the Mystery of "AGND" and "DGND,"* Analog Devices.

MT-101 Tutorial, *Decoupling Techniques*, Analog Devices.

Voltage Reference Selection and Evaluation Wizard, Analog Devices.

Data Sheets and Evaluation Boards

CN-0306 Circuit Evaluation Board (EVAL-CN0306-SDPZ)

System Demonstration Platform (EVAL-SDP-CB1Z)

AD7988-1 Data Sheet

AD7988-5 Data Sheet

AD7980 Data Sheet

ADR435 Data Sheet

AD8641 Data Sheet

OP1177 Data Sheet

ADA4841-1 Data Sheet

REVISION HISTORY

12/13—Rev. 0 to Rev. A

Changes to Title1

11/12—Rev. 0: Initial Version

(Continued from first page) Circuits from the Lab reference designs are intended only for use with Analog Devices products and are the intellectual property of Analog Devices or its licensors. While you may use the Circuits from the Lab reference designs in the design of your product, no other license is granted by implication or otherwise under any patents or other intellectual property by application or use of the Circuits from the Lab reference designs. Information furnished by Analog Devices is believed to be accurate and reliable. However, Circuits from the Lab reference designs are supplied "as is" and without warranties of any kind, express, implied, or statutory including, but not limited to, any implied warranty of merchantability, noninfringement or fitness for a particular purpose and no responsibility is assumed by Analog Devices for their use, nor for any infringements of patents or other rights of third parties that may result from their use. Analog Devices reserves the right to change any Circuits from the Lab reference designs at any time without notice but is under no obligation to do so.

©2012–2013 Analog Devices, Inc. All rights reserved. Trademarks and registered trademarks are the property of their respective owners.
CN11095-0-12/13(A)

