

Devices Connected/Referenced

ADF4350	Wideband Synthesizer with Integrated VCO
ADL5387	50 MHz to 2 GHz Quadrature Demodulator
ADL5380	400 MHz to 6 GHz Quadrature Demodulator

Wideband LO PLL Synthesizer with Simple Interface to Quadrature Demodulators

EVALUATION AND DESIGN SUPPORT

Circuit Evaluation Boards

- [ADL5387 Evaluation Board \(ADL5387-EVALZ\)](#)
- [ADL5380 Evaluation Board \(ADL5380-30A-EVALZ\)](#)
- [CN0134 Evaluation Platform \(CFTL-CN0134-EVALZ\)](#)

Design and Integration Files

- [Schematics, Layout Files, Bill of Materials](#)

CIRCUIT FUNCTION AND BENEFITS

The circuit, shown in Figure 1, highlights the ease of interfacing the ADF4350 wideband synthesizer with integrated VCO with the ADL5380 and ADL5387 wideband I/Q demodulators. In this circuit, the ADF4350 provides the high frequency, low phase noise local oscillator (LO) signal to the wideband I/Q demodulator.

This circuit configuration offers quite a few benefits that make it an attractive solution in applications requiring quadrature mixing down to baseband or to an intermediate frequency.

The ADF4350 offers RF differential outputs and, likewise, the ADL5380/ADL5387 accept differential inputs. This interface offers both ease of use and performance advantages. The differential signal configuration provides common-mode noise reduction and even order cancellation of the LO harmonics, which maintains the quadrature accuracy of the I/Q demodulators. Additionally, the output power level of the ADF4350 matches the input power requirements of the quadrature demodulators very well. As a result, an LO buffer is not necessary.

The ADF4350 outputs cover a wide frequency range from 137.5 MHz to 4400 MHz. The ADL5387 frequency range spans from 50 MHz to 2 GHz, and the ADL5380 covers the higher frequency range from 400 MHz to 6 GHz. Between the ADL5380 and ADL5387 the RF input range can span from 50 MHz to 6 GHz. Therefore, the two chip circuit configuration as shown in Figure 1 offers coverage of a wide frequency range from 50 MHz to 4400 GHz.

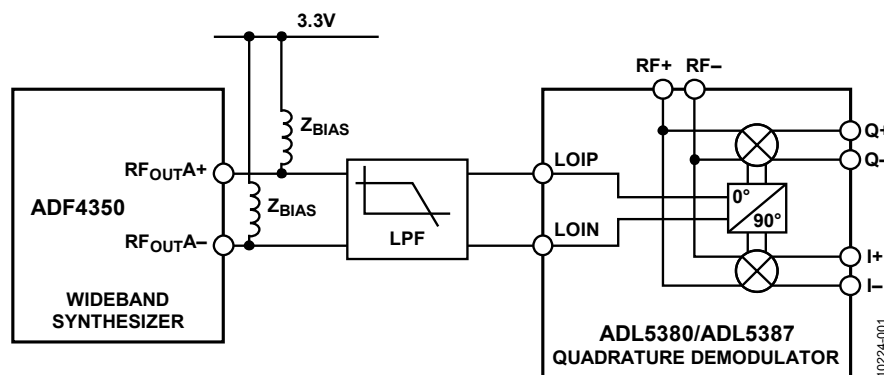

Figure 1. Simple Interface Between the ADF4350 PLL Synthesizer and the ADL5380 or ADL5387 Quadrature Demodulator (Simplified Schematic: All Connections and Decoupling Not Shown)

Rev. 0

Circuits from the Lab™ circuits from Analog Devices have been designed and built by Analog Devices engineers. Standard engineering practices have been employed in the design and construction of each circuit, and their function and performance have been tested and verified in a lab environment at room temperature. However, you are solely responsible for testing the circuit and determining its suitability and applicability for your use and application. Accordingly, in no event shall Analog Devices be liable for direct, indirect, special, incidental, consequential or punitive damages due to any cause whatsoever connected to the use of any Circuits from the Lab circuits. (Continued on last page)

CIRCUIT DESCRIPTION

The **ADF4350** is a wideband fractional-N and integer-N phase-locked loop frequency synthesizer covering the frequency range of 137.5 MHz to 4400 MHz. The **ADF4350** has an integrated voltage controlled oscillator (VCO) with a fundamental frequency range of 2200 MHz to 4400 MHz. The **ADF4350** offers high quality synthesizer performance. However, depending on the demodulator architecture, LO filtering may be required to minimize the effects of harmonics from the PLL on the quadrature accuracy of the I/Q demodulator.

Analog Devices offers quadrature demodulators that cover a wide frequency range. The **ADL5387** frequency range spans from 50 MHz to 2 GHz, and the **ADL5380** covers the higher frequency range from 400 MHz to 6 GHz. The **ADL5387** and **ADL5380** utilize two different architectures to generate the 90° phase shift between the I and Q paths. The **ADL5387** utilizes a 2 × LO architecture where the local oscillator is at twice the RF frequency, while the **ADL5380** uses a polyphase filter-based phase splitter. The polyphase architecture has a narrower fractional bandwidth (i.e., operates across less octaves) and is more sensitive to PLL harmonics compared to a 2 × LO-based phase splitter. As a result, the **ADL5380** requires harmonic filtering of the LO to maintain the quadrature accuracy of the I/Q demodulator, while filtering is only required for the 2 × LO-based **ADL5387** at the top end of its frequency range.

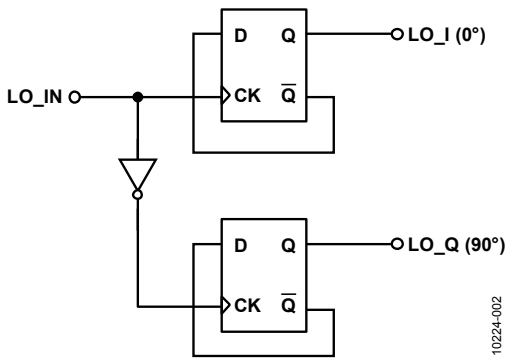

Figure 2. Simplified 2 × LO-Based Phase Splitter

Figure 2 shows a simplified 2 × LO phase splitter as implemented in the **ADL5387**. The 90° phase split of the LO path is achieved via digital circuitry that uses D-type flip-flops and an inverter. This architecture requires an external LO operating at twice the frequency of the desired LO.

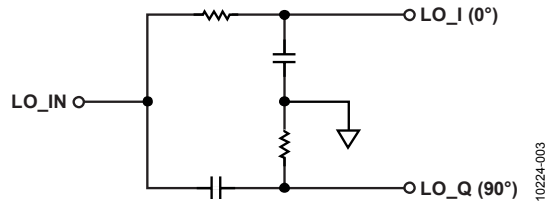

Figure 3. Simplified First Order Polyphase Filter

Figure 3 shows a simplified first order polyphase circuit, as implemented in the **ADL5380**. The polyphase circuit consists of complementary RC subcircuits that create a low-pass transfer function from input to one output, and a high-pass transfer function to the other output. If the R and C values of the two polyphased paths are matched, then both paths have the same corner frequency and, more importantly, the phase of one output tracks the other with a 90° phase shift.

Interfacing the ADF4350 PLL with the ADL5387 I/Q Demodulator

The **ADL5387** and **ADL5380** I/Q demodulators utilize different architectures to achieve the ultimate goal of generating precise quadrature signals. When interfacing with an LO synthesizer like the **ADF4350**, it is important to consider how the architectures respond to the LO signal and its harmonics. This will determine the requirement for LO filtering. Figure 4 shows the basic interface between the **ADF4350** and **ADL5387**. Depending on the frequency of operation, an LO harmonic filter may or may not be required between the **ADF4350** and **ADL5387**.

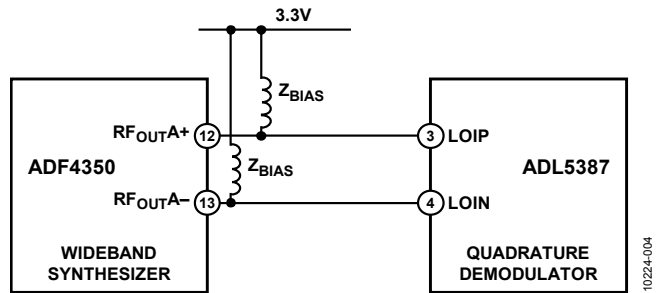

Figure 4. ADF4350 PLL Interface to the 2 × LO-Based Phase Splitter of the **ADL5387** Demodulator

In a 2 × LO-based phase splitter, the quadrature accuracy is dependent on the duty cycle accuracy of the incoming LO. The matching of the internal divider flip-flops also affects quadrature accuracy but to a much lesser extent. So a 50% duty cycle of the externally applied LO is critical for minimizing quadrature errors. Additionally, any imbalance in the rise and fall times causes even order harmonics to appear. When driving the demodulator LO inputs differentially, even order cancellation of the harmonics is achieved and results in improved overall quadrature generation.

With a target image suppression of -40 dBc, Figure 5 shows the performance of the [ADL5387](#) with the [ADF4350](#) providing the differential LO source with and without filtering. The blue signal trace representing the “Signal Generator” is the ideal case where the LO is generated using a Rhode & Schwarz signal generator with a sinusoidal output and much lower harmonic levels compared to the [ADF4350](#). This is the ideal case and the target comparison point. From Figure 5, it can be seen that filtering is not required at frequencies below 1 GHz. However, above 1 GHz small errors due to harmonics of the LO become a larger percentage of the input period. In this case, filtering should be used to further attenuate the even order harmonics of the LO and so that the I/Q demodulator’s specified quadrature accuracy can be achieved.

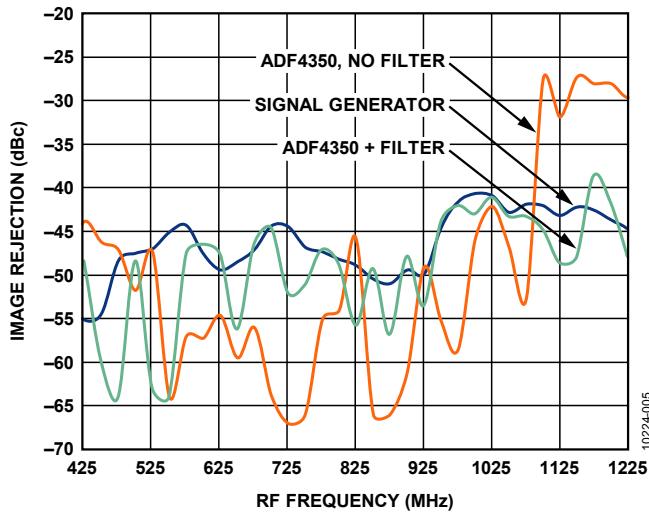

Figure 5. [ADL5387](#) Image Rejection vs. RF Frequency

Interfacing the [ADF4350](#) PLL with the [ADL5380](#) Quadrature Demodulator

Unlike the [ADL5387](#), the polyphase architecture of the [ADL5380](#)’s phase splitter requires filtering of the [ADF4350](#) outputs, as shown in Figure 6. Filtering is required to attenuate the odd order harmonics of the LO to minimize errors in the quadrature generation block of the [ADL5380](#). From measurement and simulation as explained in [CN-0134](#), the odd order harmonics contribute more than even order harmonics to quadrature errors. Figure 7 shows the measurement results when the [ADF4350](#) outputs are filtered before they are applied to the differential LO inputs of the [ADL5380](#). After filtering, the resulting image rejection is comparable to what is achievable from a low harmonic signal generator.

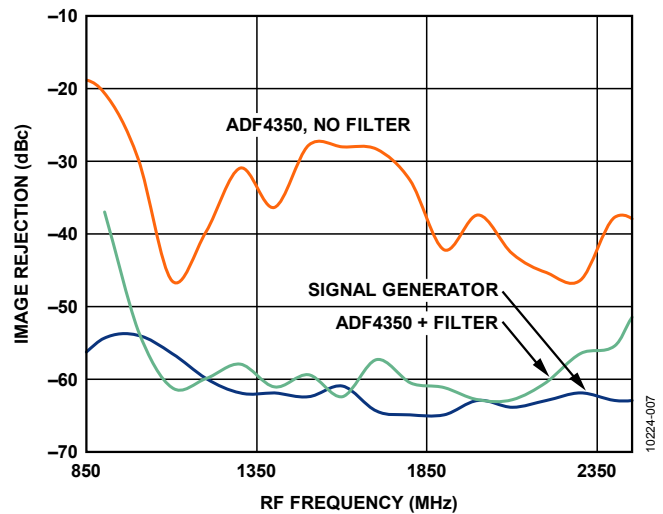

Figure 7. [ADL5380](#) Image Rejection vs. Frequency.

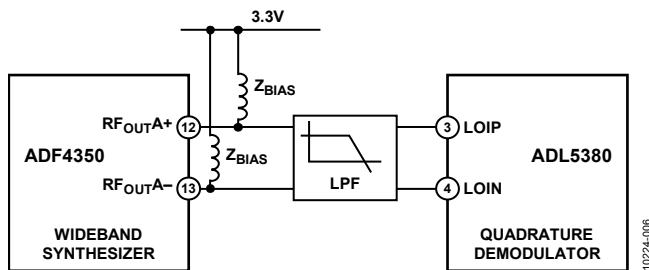

Figure 6. [ADF4350](#) Interface to the Polyphase Filter Architecture of the [ADL5380](#) Demodulator

Filtering Requirements

In summary, LO filtering the [ADF4350](#) outputs to suppress the harmonics of the fundamental helps to maintain the phase accuracy of the quadrature signals of the demodulator. In the case of the [ADL5380](#), which uses a polyphase architecture, filtering is a requirement. The [ADL5387](#) architecture consists of digital circuitry which is more immune to the harmonics of the LO signal. Therefore filtering may not be required, depending on the frequency of operation.

In the case where filtering is necessary, Figure 8, shows an example LO output filter schematic, and Table 1, summarizes the filter component values. This circuit is flexible and provides four different filter options to cover four different bands. The filters were designed for a 100Ω differential input and 50Ω differential output to match the LO input requirements of the demodulator. A Chebyshev response was used for optimal filter roll-off at the expense of increased pass-band ripple. Please refer to [CN-0134](#) for a more detailed discussion on the filtering of the [ADF4350](#) outputs.

Table 1. ADF4350 RF Output Filter Component Value (DNI = Do Not Insert)

Frequency Range (MHz)	Z _{BIAS}	L1 (nH)	L2 (nH)	C1a (pF)	C1c (pF)	C2a (pF)	C2c (pF)	C3a (pF)	C3c (pF)
a. 500–1300	27 nH 50 Ω	3.9	3.9	DNI	4.7	DNI	5.6	DNI	3.3
b. 850–2450	19 nH (100 Ω in position C1c)	2.7	2.7	3.3	100 Ω	4.7	DNI	3.3	DNI
c. 1250–2800	50 Ω	0 Ω	3.6	DNI	DNI	2.2	DNI	1.5	DNI
d. 2800–4400	3.9 nH	0 Ω	0 Ω	DNI	DNI	DNI	DNI	DNI	DNI

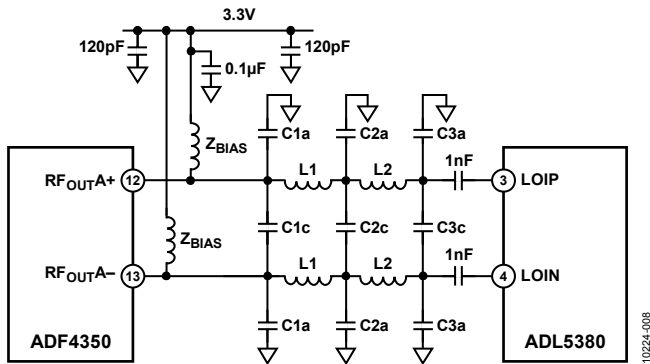

Figure 8. ADF4350 RF Output Filter Schematic

COMMON VARIATIONS

The interface discussed above is applicable to any PLL with differential LO outputs and to any 1 × LO or 2 × LO-based I/Q demodulator. The ADL5382 is a 1 × LO-based I/Q demodulator that operates from 700 MHz to 2700 MHz and provides slightly higher IP3 than the ADL5380. The AD8347 (1 × LO) and AD8348 (2 × LO) are lower power I/Q demodulators that integrate front-end variable gain amplifiers and fixed-gain baseband amplifiers.

CIRCUIT EVALUATION AND TEST

The circuits shown in Figure 4 and Figure 6 were implemented using the CN-0134 evaluation board (CFTL-0134EVALZ) and the ADL5387 or ADL5380 evaluation boards. The CN-0134 evaluation platform includes the ADF4350, pads for an LO filter, and differential LO outputs to SMA connectors.

The ADF4350 must be programmed, and the software is contained on the CD that accompanies the evaluation board.

Table 2 provides the ordering guide for the various evaluation boards.

The CN-0134 evaluation board is configured by default to an 850 MHz to 2450 MHz filter design as specified in Table 1. To implement an alternative filter, the appropriate components must be swapped out.

Table 2. Evaluation Board Information

	Evaluation Board
ADL5387	ADL5387-EVALZ
ADL5380	ADL5380-30A-EVALZ ADL5380-29A-EVALZ
Low Band (400 MHz to 3 GHz) Mid Band (3 GHz to 4 GHz)	
CN-0134	CFTL-0134-EVALZ

Equipment Needed

- Windows XP, Windows Vista (32-bit), or Windows 7 (32-bit) PC with USB port
- Evaluation boards as listed in Table 2
- RF source (Rohde & Schwarz SMT06 or equivalent)
- Spectrum analyzer (Rohde & Schwarz FSEA30 or equivalent)
- Power supplies:
 - ADL5387-EVALZ: +5 V
 - ADL5380-30A-EVALZ: +5 V
 - CFTL-0134-EVALZ: +5.5 V

Test

The CN-0134 evaluation platform allows easy evaluation and has an integrated crystal oscillator on board. A PC with the ADF4350 software is required to program the synthesizer to the desired LO frequency. The ADL5387/ADL5380 quadrature demodulator will downconvert the RF frequency to baseband. The differential I and Q baseband outputs are applied to the FSEA spectrum analyzer in the FFT mode, and image rejection is measured.

Additional documentation can be found in the following design support packages for CN-0245, CN-0134, and CN-0144:

CN-0245 Design Support Package:
www.analog.com/CN0245-DesignSupport

CN-0134 Design Support Package:
www.analog.com/CN0134-DesignSupport

CN-0144 Design Support Package:
www.analog.com/CN0144-DesignSupport

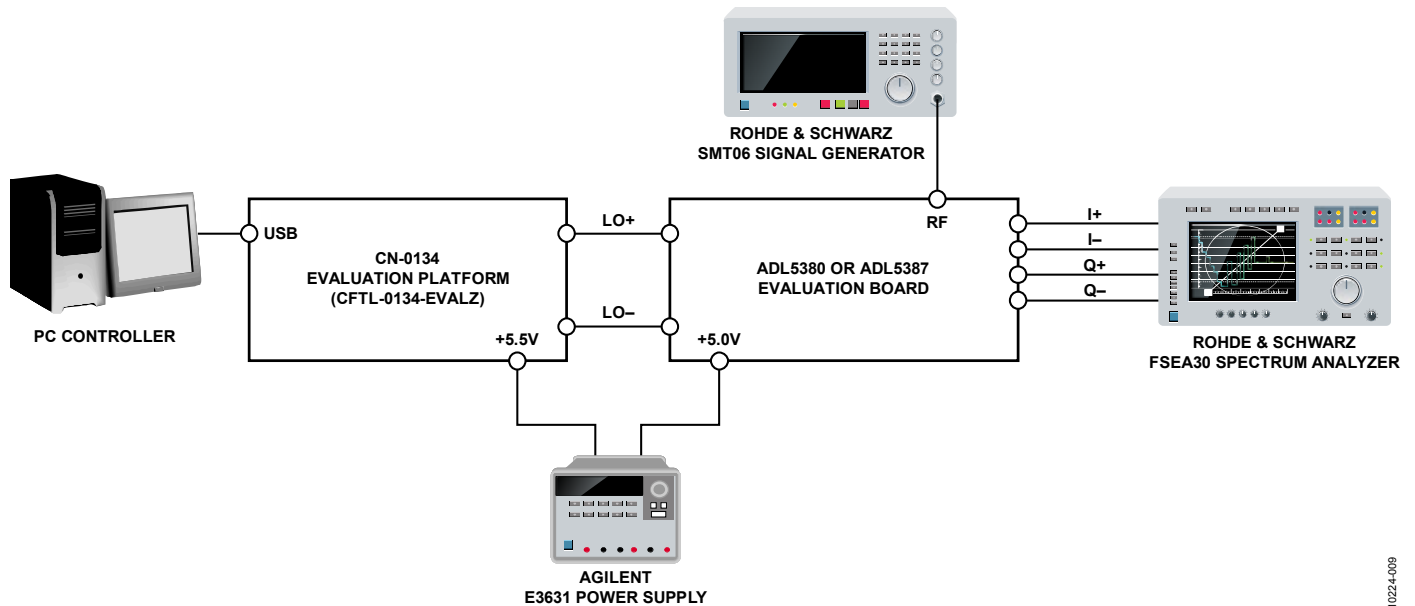

Figure 9. Functional Block Diagram of Test Setup

LEARN MORE

Nash, Eamon, AN-1039 Application Note. *Correcting Imperfections in IQ Modulators to Improve RF Signal Fidelity*. Analog Devices.

CN-0245 Design Support Package:
www.analog.com/CN0245-DesignSupport

CN-0134 Design Support Package:
www.analog.com/CN0134-DesignSupport

CN-0144 Design Support Package:
www.analog.com/CN0144-DesignSupport

ADIsimRF Design Tool

ADIsimPLL Design Tool

Data Sheets and Evaluation Boards

[ADL5387 Data Sheet and Evaluation Board](#)

[ADL5380 Data Sheet and Evaluation Board](#)

[ADF4350 Data Sheet and Evaluation Board](#)

REVISION HISTORY

12/11—Revision 0: Initial Version

(Continued from first page) Circuits from the Lab circuits are intended only for use with Analog Devices products and are the intellectual property of Analog Devices or its licensors. While you may use the Circuits from the Lab circuits in the design of your product, no other license is granted by implication or otherwise under any patents or other intellectual property by application or use of the Circuits from the Lab circuits. Information furnished by Analog Devices is believed to be accurate and reliable. However, Circuits from the Lab designs are supplied "as is" and without warranties of any kind, express, implied, or statutory including, but not limited to, any implied warranty of merchantability, noninfringement or fitness for a particular purpose and no responsibility is assumed by Analog Devices for their use, nor for any infringements of patents or other rights of third parties that may result from their use. Analog Devices reserves the right to change any Circuits from the Lab circuits at any time without notice but is under no obligation to do so.

©2011 Analog Devices, Inc. All rights reserved. Trademarks and registered trademarks are the property of their respective owners.
 CN10224-0-12/11(0)



www.analog.com