

Choose the Right Voltage Regulator to Extend Battery Life in Wearables

Introduction

Wearable devices have emerged as the next big market opportunity in the electronics industry. Smart watches, as shown in Figure 1, are among the most popular wearable items today. The healthcare market, including the medical, fitness and wellness sectors, promises even broader opportunities. The majority of wearable gadgets have a number of things in common.

Wearable devices must:

- Be always ready for use
- Be small and lightweight in order to be easy to wear
- Last a sufficiently long time on a re-charge or on a disposable battery
- Support short periods of activity, spending the majority of time in idle or sleep mode
- Last a very long time in idle or sleep mode

These requirements place heightened demands on all the technologies underlying the products. Wearable batteries are smaller, yet they must last as long as, or even longer than, batteries for larger devices. For example, smart phone batteries have a range of capacities around 2000mAh. The battery of a smart watch, while much smaller in size and with a charge about 10 times smaller, is still required to operate for the same time duration between recharges as its smart phone big brother. Correspondingly, a quantum leap in performance is required from the rest of the watch's electronic components. Namely, they must be small and consume minimum power both in active mode and in passive (stand-by and shutdown) mode.

Low-Power Consumption All Around

Until recently the primary focus for voltage regulation design has been the efficiency of power delivery in active mode, from light to peak to full load. Business is routinely won and lost over a fraction of a percent of efficiency advantage. With the efficiency curve well understood and opportunities for improvement reaching saturation the focus is shifting to optimizing the power savings in passive mode. Passive mode



Figure 1. Smart Watch

corresponds to the system being in idle mode (still on but in standby) or in sleep mode (when the system is in shutdown).

This shift is necessary due to the popularity of wearable devices, which spend a lot of time in a passive mode with only infrequent periods of activity. It's clear that if idle and sleep mode are the dominant modes this is where the power savings need to come from. Here, indeed, every nanoampere counts since it is amplified over long periods of inactivity and ends up robbing precious charge from the battery.

As an example, a 40mAh, 1.55V silver oxide coin cell battery is a good candidate for powering a wearable device. If the current drawn by the wearable device in passive mode is 4 μ A the battery will have a shelf life of about one year before it runs out of charge. A reduction in current draw of a single microampere would increase the wearable shelf life by approximately three months! With this in mind, consider the conventional product portfolio of ultra-portable voltage regulators, which contribute tens of microamps of quiescent current and several microamps of shut-down current to the overall device current consumption. We can be quickly convinced that any improvement in these parasitic currents will be beneficial.

Regulator Low Shutdown Current

To meet the battery life needs of wearables we must, therefore, look at a new breed of voltage regulators with ultra-low current in passive mode. An example is [MAX1722](#), a boost converter optimized for wearable applications. Aggressive power savings techniques have been employed to minimize the current consumption when the system is in sleep mode and the regulator is shutdown. In shutdown all the regulator control circuits are switched off, leaving only the unavoidable parasitic leakages which produce minimal discharge of the battery and the output capacitor. Leakage of a few nanoamps occurs at the BATT pin (I_{LB} in Figure 2), and tens of nanoamps at the OUT pin (I_{LO}). The leakage at the OUT pin is higher due to the presence of the power train on this pin.

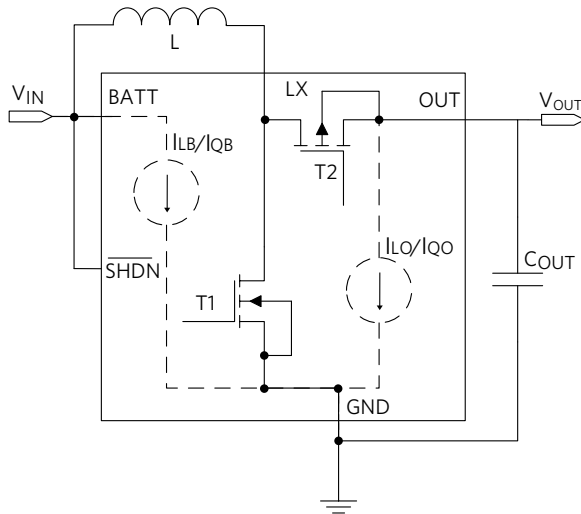

Figure 2. Boost Converter Quiescent/Shutdown Current

Regulator Low Quiescent Current

When the system is in idle mode the voltage regulator is typically in stand-by, ready to come alive on command. In stand-by the load handled by the voltage regulator is minimal, hence, its quiescent current becomes important as it significantly affects the regulator efficiency. In this state MAX1722 operates with minimum overhead, resulting in a quiescent current of a few nanoamps at the input (I_{QB} in Figure 2) and a few microamps at the output (I_{QO}), where all the control circuitry is referred to. Figure 3 shows that the MAX1722 typical quiescent current is a miserly $1.5\mu\text{A}$ for a 3.3V output. The curve is measured at ambient temperature. Over the temperature range of 0°C to $+85^\circ\text{C}$ this parameter is guaranteed to stay below $3.6\mu\text{A}$.

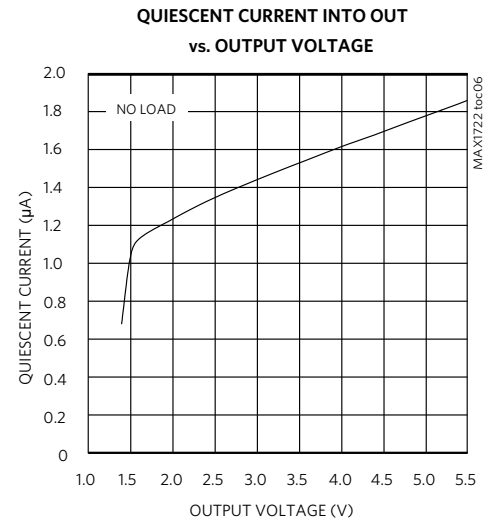

Figure 3. MAX1722 Boost Converter Quiescent Current Into OUT Pin

Thus, with its 150mA in active mode and ultra-low current in passive mode, MAX1722, housed in a small $2\text{mm} \times 2\text{mm}$ μDFN package, is an ideal solution for voltage regulation in wearable applications.

Conclusion

We have discussed the importance of minimizing the voltage regulator quiescent and shut down currents when the system it is powering is in idle or sleep mode. The example using MAX1722 showed that when these two parameters are reduced an order of magnitude or more below conventional products the battery life is dramatically improved. Future products from Maxim will continue to push the envelope by further reducing the regulator size and further isolating its circuitry from the battery and the output capacitor in passive mode. This will further reduce the parasitic leakages which rob current from the energy storage elements, ultimately extending the system operating time.

Learn more:

[MAX1722: \$1.5\mu\text{A}\$ \$I_Q\$, Step-Up DC-DC Converters in TSOT and \$\mu\text{DFN}\$](#)

Design Solutions No. 5

Need Design Support?
Call 888 MAXIM-IC (888 629-4642)

Maxim Integrated
160 Rio Robles
San Jose, CA 95134 USA
408-601-1000
maximintegrated.com

