

# DESIGN NOTES

## Tiny Synchronous Step-Up Converter Starts Up at 700mV

Design Note 428

Dave Salerno

### Introduction

Alkaline batteries are convenient because they're easy to find and relatively inexpensive, making them the power source of choice for portable instruments and devices used for outdoor recreation. Their long shelf life also makes them an excellent choice for emergency equipment that may see infrequent use but must be ready to go on a moment's notice. It is important that the DC/DC converters in portable devices operate over the widest possible battery voltage range to extend battery run time, and thus save the user from frequent battery replacement.

Single-cell alkaline batteries, with a 1.6V to 0.9V range, present a special challenge to DC/DC converters because of their low voltage and the fact that their internal resistance increases as the battery discharges. Thus, a DC/DC converter that can both start up and operate efficiently at low input voltages is ideally suited for single-cell alkaline products.

The LTC<sup>®</sup>3526L is a 1MHz, 550mA synchronous step-up (boost) converter with a wide input voltage range of 0.7V to 5V and an output voltage range of 1.5V to 5.25V. Housed in a 2mm × 2mm DFN package, the LTC3526L has

**Lower Start-Up Devices for Energy Harvesting  
Work Below 100mV—See the LTC3108**

a typical startup voltage of just 700mV, with operation down to 400mV once started. Despite the LTC3526L's tiny solution size, it includes many advanced features, including output disconnect, short circuit protection, low noise fixed frequency operation, internal compensation, soft-start, thermal shutdown and Burst Mode<sup>®</sup> operation for high efficiency at light load. For low noise applications, the LTC<sup>®</sup>3526LB offers fixed frequency operation at all load currents. With an output voltage range that extends down to 1.5V, the LTC3526L and LTC3526LB can even be used in applications previously requiring a boost converter followed by a buck converter.

A typical single-cell boost application is shown in Figure 1. In this example the LTC3526LB is used to generate 1.8V for a Bluetooth radio application. The LTC3526LB was selected for its small size, minimal external component count and low-noise, fixed frequency operation at all load currents. A graph of output current capability versus input voltage is shown in Figure 2. Note that the converter starts up at 700mV at no load and once run-

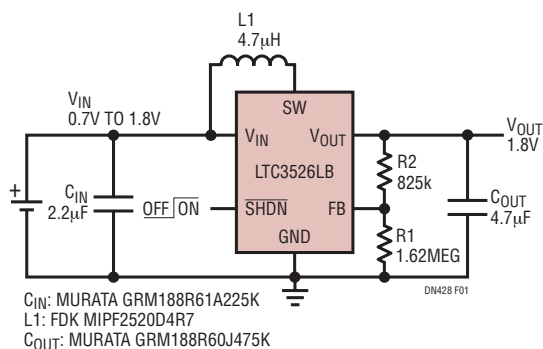

**Figure 1. Single-Cell 1.8V Boost Converter for a Bluetooth Radio Application Features a Low Startup Voltage and Uses a Monolithic Chip Inductor for a Maximum Component Height of Just 1mm.**

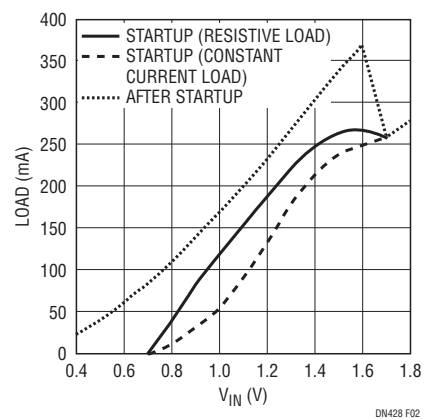

**Figure 2. Maximum Load Capability During and After Startup for the Circuit in Figure 1.**

ning, can deliver 25mA of output current with an input voltage of only 400mV. The 1MHz switching frequency allows the use of small, low profile inductors, such as the monolithic chip inductor shown in this application. This provides a complete solution with a footprint that's just 36mm<sup>2</sup> with a 1mm profile.

Many new battery types are available to the consumer, some of which are aimed at high-tech, high power applications. One of these is the disposable lithium AA/AAA battery, which offers a significant improvement in runtime over traditional alkaline batteries. Furthermore, in applications that see infrequent use, the long shelf life of lithium batteries gives them a performance edge over nickel-based rechargeable batteries, which have a high self-discharge rate.

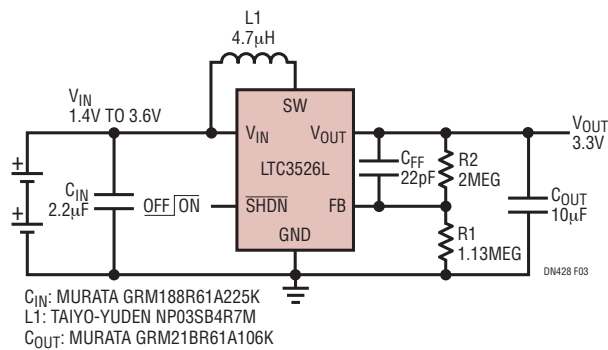

**Figure 3. Two AA Lithium Cell to 3.3V Boost Converter with 250mA Load Capability Maintains High Efficiency Over Three Decades of Load Current and Operates with  $V_{IN} \geq V_{OUT}$ .**

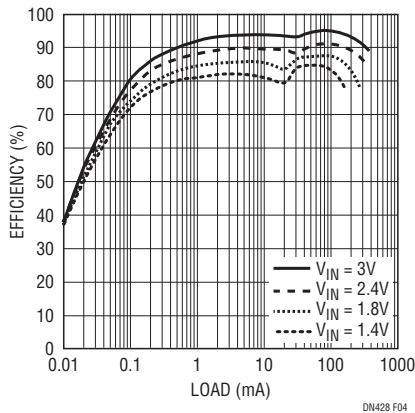

**Figure 4. Efficiency vs Load for the Circuit in Figure 3.**

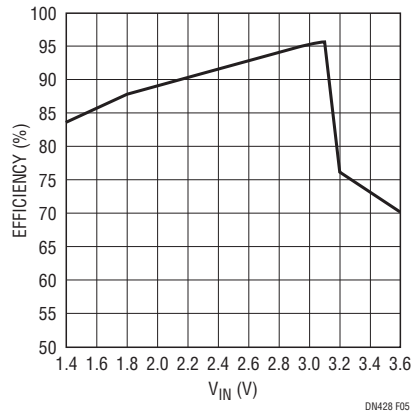

**Figure 5. Efficiency vs  $V_{IN}$  for the Circuit in Figure 3 (at 100mA Load Current).**

One characteristic of the lithium battery is that its voltage can be as high as 1.8V when the battery is fresh, compared to 1.6V for a typical alkaline battery. This is a problem for 2-cell alkaline applications that use a traditional boost converter to produce a 3.3V output from an alkaline 3.2V max input. Most boost converters cannot maintain regulation when the input is higher than the output, as it is with two fresh lithium batteries (3.6V).

The LTC3526L solves this problem by maintaining regulation even when the input voltage exceeds the output voltage. An example of a 2-cell to 3.3V boost converter using the LTC3526L is shown in Figure 3. A small feed-forward capacitor has been added across the upper divider resistor to reduce output ripple in Burst Mode operation. Efficiency vs load curves are shown in Figure 4. These curves demonstrate the high efficiency at light load made possible by the low 9µA quiescent current of Burst Mode operation. The curve in Figure 5 illustrates the efficiency at input voltages above and below the output voltage.

### Conclusion

The LTC3526L is a highly integrated step-up DC/DC converter in a 2mm × 2mm package designed to easily fit a wide variety of battery-powered applications. Low startup and operating voltages extend runtime in single-cell applications. It even regulates in step-down situations where the fresh battery voltage ( $V_{IN}$ ) may exceed  $V_{OUT}$ . For high efficiency at light loads, or low noise operation, it offers a choice of Burst Mode or fixed frequency operation.

[Data Sheet Download](#)

[www.linear.com](http://www.linear.com)

For applications help,  
call (408) 432-1900, Ext. 3725