



# DESIGN NOTES

## Tiny Step-Up/Step-Down Power Supply Delivers 3.3V at 1.3A in Battery-Powered Devices – Design Note 271

Keith Szolusha

### Introduction

Many of today's cellular phones, PDAs, MP3 players and other portable devices require that a consistent 3.3V power supply be delivered from a single, rechargeable lithium-ion battery. The problem is that a Li-Ion battery at full charge has a voltage somewhat higher than 3.3V and loses voltage over the life of a charge to less than 3.3V. A power supply that depends on a Li-Ion requires a voltage regulator that can maintain consistent 3.3V output from both high and low inputs. Since typical Li-Ion applications are portable mass-market devices where the focus is on short time-to-market, long battery life, small size and low cost, the regulator must take minimal space, be highly efficient and use inexpensive off-the-shelf components wherever possible.

Figure 1 shows a simple and efficient SEPIC converter that provides up to 1.3A output at 3.3V with input from a single 2.7V to 4.2V battery. Its simplicity, low cost, efficiency and small component size (no component is higher than 3.1mm) satisfy many of the size and power-consumption requirements of battery-powered portable devices.

### Regulated Output Voltage from a Range of Inputs

Although a SEPIC is only one of many possible configurations for a DC/DC converter, it has a major advantage over other choices when applied in a modern portable device. The SEPIC in Figure 1 delivers 3.3V output throughout the input voltage range, 2.7V to 4.2V. One alternative to the SEPIC configuration is a simple step-down converter. A step-down converter delivers 3.3V as long as the battery voltage remains above 3.6V, but it begins to drop out when the battery voltage drops below 3.6V, producing output voltage a few hundred millivolts below the input voltage. The output voltage will drop all the way down below 2.5V as the input voltage drops to 2.7V.

### Highly Efficient

This design can provide DC/DC conversion efficiencies of up to 78%, important for maximizing battery life in portable devices. Figure 2 shows the efficiency curve for various input voltages and output currents. Note that above 10mA output the circuit is greater than 70%

LT, LTC, LTM, Linear Technology and the Linear logo are registered trademarks of Linear Technology Corporation. All other trademarks are the property of their respective owners.

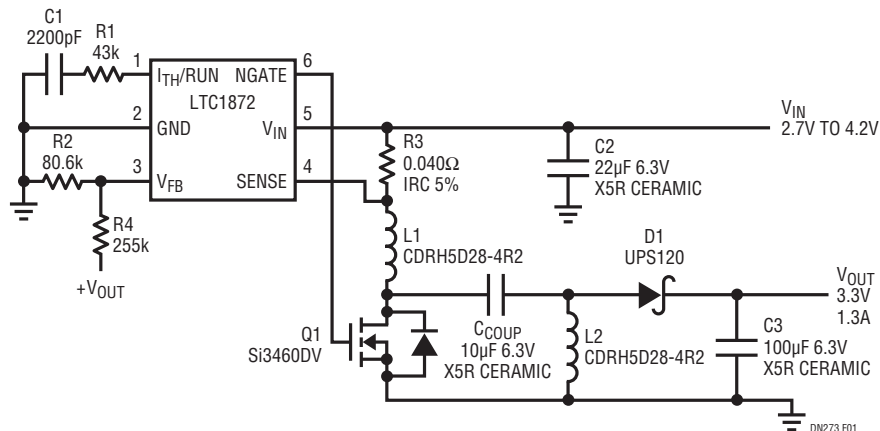

**Figure 1. Converting Lithium-Ion Battery Voltage to 3.3V, 1.3A with SOT-23 DC/DC Converter Has Minimal Components Count and 3.1mm Maximum Height**

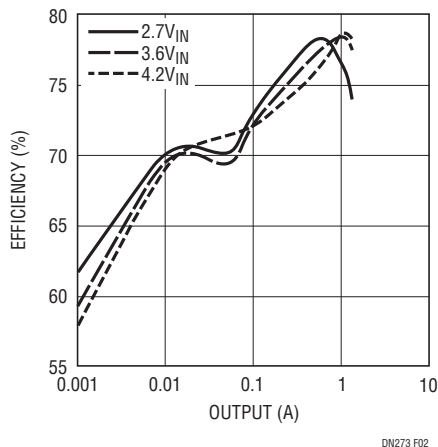

**Figure 2. Typical Efficiency of Lithium-Ion Battery to 3.3V, 1.3A LTC1872 DC/DC Converter**

efficient and climbs to 78% efficiency at 1A output. It remains greater than 60% for output currents as low as 1mA, due mainly to the low quiescent current of the LTC<sup>®</sup>1872. If a shutdown mode is desired, the LTC1872's extremely low 22 $\mu$ A (maximum) shutdown current also prolongs battery life.

The simplicity of this circuit minimizes cost, board space and design headaches. This 550kHz current mode SOT-23 controller drives a single TSOP-6 N-channel MOSFET. The 10 $\mu$ F ceramic coupling capacitor has extremely high RMS ripple current capabilities for its small size and cost. The two small 4.2 $\mu$ H, 2.2A inductors (L1 and L2) are no more than 3.0mm high and need not be placed next to each other as in the alternative magnetics choice, a single bigger and costlier transformer with maximum height well above 3mm. In general, uncoupled power inductors are available from more sources and come in more inductance and DC current ratings than

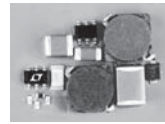

16mm  $\times$  12mm  
3.1mm MAX HEIGHT



CTX2-2P TRANSFORMER  
9mm  $\times$  9mm  
6.0mm MAX HEIGHT

**Figure 3. Two Inductor Design Offers Better Performance Than a Design Using a Transformer**

equivalent transformers. A transformer also limits the flexibility of this layout. Figure 3 demonstrates how two separate inductors (with a combined cost still less than an equivalent transformer) are placed to minimize the circuit size and form the shortest possible high frequency AC switching path and thus the most noise immune layout possible. The most likely choice for a transformer replacement of the two inductors is shown for reference. The transformer has a maximum height of 6.0mm, well above the 3.1mm maximum height of the two inductor circuit. The bulky 4-pin transformer increases the size of the circuit and makes layout more difficult.

The 100 $\mu$ F ceramic output capacitor has a high ripple current rating and extremely low ESR resulting in limited output voltage ripple. This particular design requires only a 22 $\mu$ F ceramic input capacitor because SEPICs have low input ripple current (due to the continuous current in inductor L1). The tiny Schottky diode with 2A current rating takes very little space and the whole board can be kept very small by using the LTC1872 in its thin SOT-23 package.

The LTC1872 provides a 2.5V undervoltage lockout feature that prevents current runaway at low input voltages, particularly important for Li-Ion battery-powered devices.

Data Sheet Download

[www.linear.com](http://www.linear.com)

For applications help,  
call (408) 432-1900