



DESIGN NOTES

A Single Amplifier, Precision High Voltage Instrument Amp

Design Note 25

Walt Jung and George Erdi

Instrumentation amplifier (IA) circuits abound in analog systems, in fact virtually any linear applications handbook will show many useful variations on the concept⁽¹⁾. While this may be somewhat bewildering to a newcomer, all the variations have uses which are differentiated and valuable. A good working knowledge of the alternate forms can be a powerful tool towards designing cost-effective high performance linear circuits.

A case in point is a single amplifier *precision qualified* high voltage IA. This circuit must withstand very high common mode voltages at the input, yet it should still

be relatively simple, while at the same time capable of high performance. Whereas dual summing amplifier setups can provide high input-voltage qualifications, a more simple single amp solution is often sought. An IA topology which achieves all the above objectives is shown in Figure 1, the "Precision High Voltage IA." The circuit employs the virtues of two key parts in performing its function; the resistor array and the op amp used with it.

LT, LT, LTC, LTM, Linear Technology and the Linear logo are registered trademarks of Linear Technology Corporation. All other trademarks are the property of their respective owners.

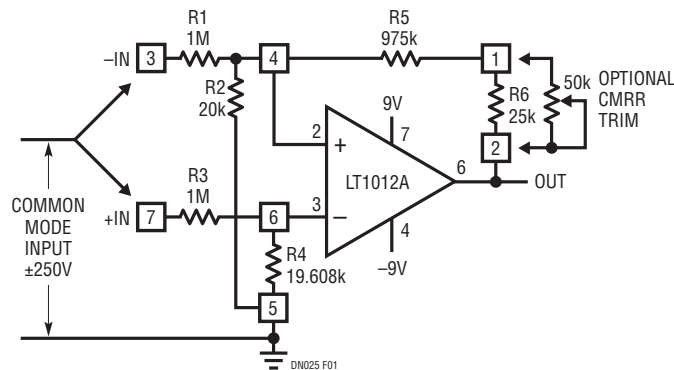

TYPICAL PERFORMANCE:

COMMON MODE REJECTION RATIO = 74dB (RESISTOR LIMITED)
 WITH OPTIONAL TRIM = 130dB
 OUTPUT OFFSET (TRIMMABLE TO ZERO) = 500 μ V
 OUTPUT OFFSET DRIFT = 10 μ V/ $^{\circ}$ C
 INPUT RESISTANCE = 1M (CM)
 2M (DIFF)
 BANDWIDTH = 13kHz
 BATTERY CURRENT = 370 μ A

R1-R6: VISHAY 444 ACCUTRACT THIN-FILM
 SIP NETWORK
 X: VISHAY 444 PIN NUMBERS
 VISHAY INTERTECHNOLOGY, INC.
 63 LINCOLN HIGHWAY
 MANVERN, PA 19355

Figure 1. ± 250 Common Mode Range Instrumentation Amplifier ($A_V = 1$)

Here, the resistor network is a precision high-voltage design thin-film system, comprised of R1 through R6. This array, a Vishay type 444, is a thin-film SIP with a 250V/100mW input rating for R1-R3. This high voltage rating allows direct connection to AC or DC line shunts for current monitoring, level shifting from high voltage DC rails, and other such interfacing feats normally uncommon to low voltage IC circuits. The 444 network has a basic common-mode attenuation of 50 times, thus an op amp with an input voltage range of $\pm 10V$ would allow a theoretical range at input pins 3-7 of $\pm 500V$. So, devices with standard $\pm 15V$ supplies are basically compatible with the network operating parameters. While the network has a CM attenuation of 50 times, the differential signal scaling is nominally unity, with an error of $\pm 0.1\%$. Functionally then, the differential mode input signal between pins 3-7 is referred at the output of this circuit to the local ground (pin 5 of the network), with unity gain scaling.

A second keen application point which is a large determining factor towards the overall success of this type of IA is the relative precision of the op amp A1. Indeed, this amplifier is the second "key ingredient" towards high overall performance. Because the circuit basically amplifies the input offset voltage of A1 by the same factor as the CM attenuation, both the initial offset and the drift of A1 can become limitations, as can the CMRR of the device. Here an LT[®]1012A op amp is used, a device with a 25 μV (max) input offset voltage; the output offset will then be 1.25mV or less, worst case. The overall CMRR of the circuit has two primary sources for errors, the basic ratio match of the network halves,

and to a lesser degree, the CMRR of A1. The LT1012A has a minimum CMRR of 114dB, while the network is factory trimmed to a 0.02% match, corresponding to a 74dB CMRR. For 120dB or more CMRR, a 50k trimmer can be substituted for R6.

While A1 is shown operating from $\pm 9V$ battery supplies (a feature possible by virtue of the 370 μA quiescent current) the LT1012 device family can also be used on standard $\pm 15V$ supplies, or on lower voltage supplies down to $\pm 1.2V$ (with reduced CM range, of course). With the 9V supplies shown, input ranges of $\pm 250V$ or more to the circuit will not tax the network.

For single battery applications (i.e. when pin 4 is grounded), the LT1012A should be replaced by a single supply op amp such as the LT1006 or the LT1077. These devices can handle about $-250mV$ of negative common mode voltage, while maintaining accuracy. Therefore, the 250V positive common mode range is unchanged, but the negative common mode range is reduced to $-12V$.

Using an LT1006, bandwidth and battery current are basically unchanged. With the LT1077 micropower op amp, battery current is reduced to 45 μA but at the expense of bandwidth (= 4.5kHz). Offset voltage and drift specifications are degraded by approximately a factor of two using the LT1006 or the LT1007 compared to the LT1012A.

References

1. Jung, W.G. *IC Op Amp Cookbook, 3d Ed.*, Ch 7, "Amplifier Techniques," Howard W. Sams, Indianapolis, IN 1986.

Data Sheet Download

www.linear.com

For applications help,
call (408) 432-1900

Linear Technology Corporation
1630 McCarthy Blvd., Milpitas, CA 95035-7417
(408) 432-1900 • FAX: (408) 434-0507 • www.linear.com

dn25f_conv IM/GP 0789 165K • PRINTED IN THE USA

© LINEAR TECHNOLOGY CORPORATION 1989