

TOP VIEW

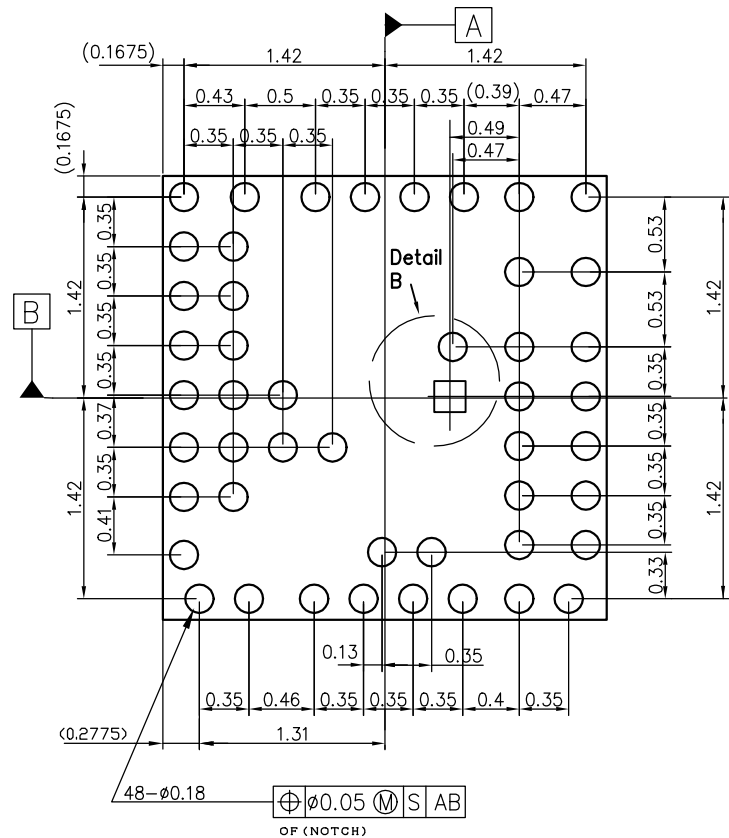

BOTTOM VIEW

J-J' Cross section

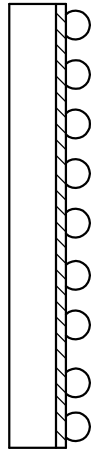
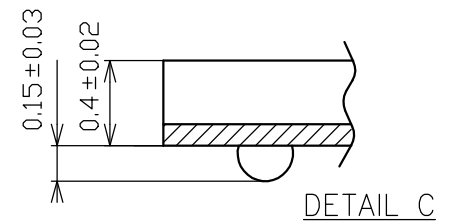
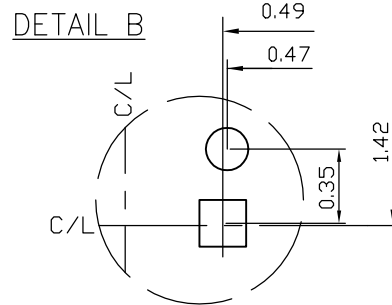
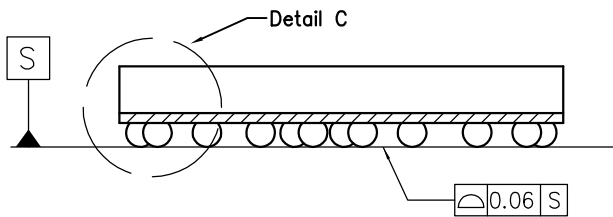

Note

1. Terminal pitch is defined by terminal center to center value.
2. Outer dimension is defined by center lines between scribe lines.
3. Referenced Casio Micronics Co., Ltd. Dwg. # 050527-01.

-DRAWING NOT TO SCALE-



TITLE:  
PACKAGE OUTLINE, WLP (MAX 2160)

APPROVAL  
PRADIP PATEL  
01/12/06

DOCUMENT CONTROL NO.  
21-0173

REV.  
A 1/1