

DIMPLE VERSION

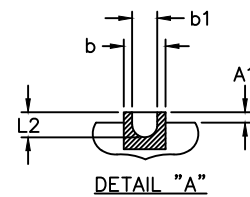
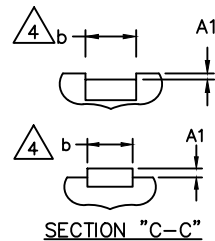
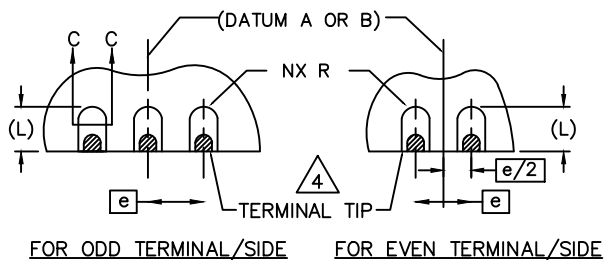
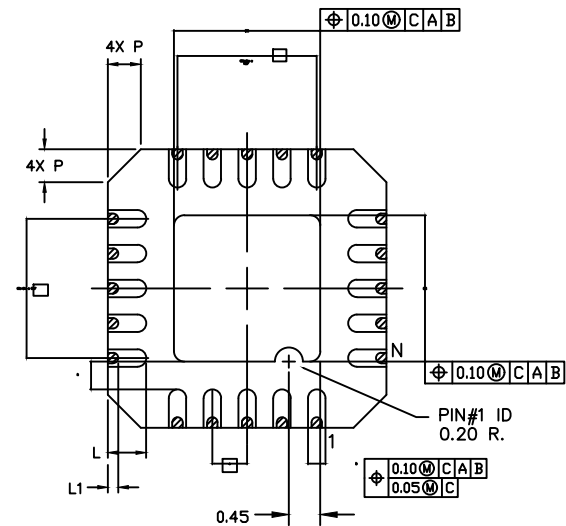
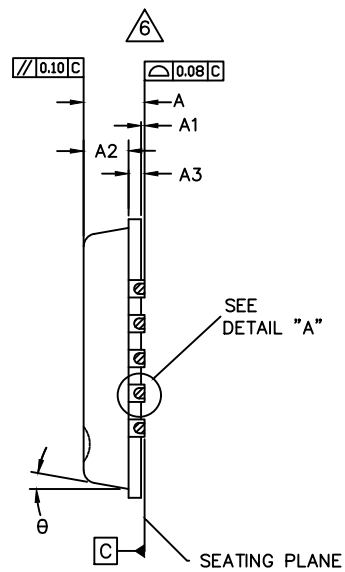
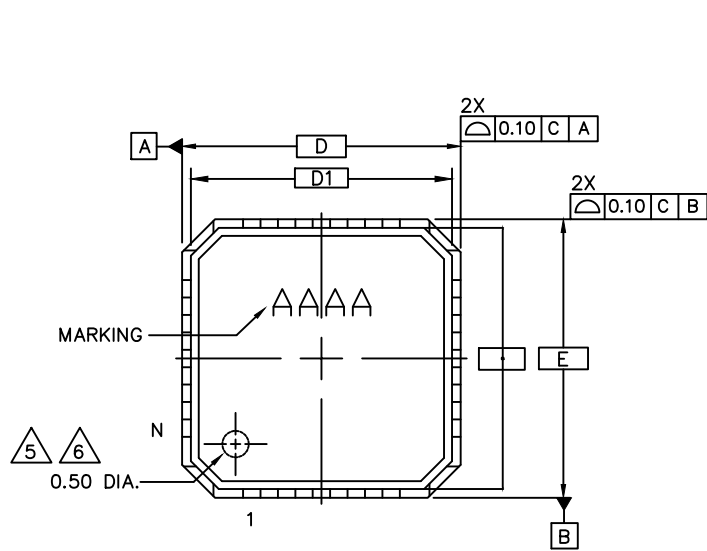

TITLE:
PACKAGE OUTLINE, 20L, 4x4x0.85MM
SIDE WETTABLE QFN PKG.

APPROVAL

DOCUMENT CONTROL NO.
21-0576

REV. 1/4
B

-DRAWING NOT TO SCALE-

DiMPLE VERSION

NOTES

1. DIE THICKNESS ALLOWABLE IS 0.305mm MAXIMUM (0.012 INCHES MAXIMUM).
2. DIMENSIONING & TOLERANCES CONFORM TO ASME Y14.5M. - 1994.
3. N IS THE NUMBER OF TERMINALS.
4. DIMENSION *b* APPLIES TO PLATED TERMINAL AND IS MEASURED BETWEEN 0.15 AND 0.30mm FROM TERMINAL TIP.
5. THE PIN #1 IDENTIFIER MUST BE EXISTED ON THE TOP SURFACE OF THE PACKAGE BY USING INDENTATION MARK OR OTHER FEATURE OF PACKAGE BODY.
6. UNILATERAL COPLANARITY ZONE APPLIES TO EXPOSED PAD AS WELL AS THE TERMINALS.
7. ALL DIMENSIONS ARE IN MILLIMETERS.
8. MEETS JEDEC MO220.
9. MATERIAL MUST COMPLY WITH BANNED AND RESTRICTED SUBSTANCES SPEC # 10-0131.
10. MARKING SHOWN IS FOR PACKAGE ORIENTATION REFERENCE ONLY.
11. ALL DIMENSIONS APPLY TO PbFREE (+) PKG. CODE ONLY.

SYMBOL	COMMON DIMENSIONS			NOTE
	MIN.	NOM.	MAX.	
A	0.80	0.85	0.90	
A1	0.00	0.01	0.05	6
A2	0.60	0.65	0.70	
A3	0.20 REF.			
b	0.20	0.25	0.30	
b1	0.10	0.15	0.20	
D	3.90	4.00	4.10	
D1	3.75 BSC			
E	3.90	4.00	4.10	
E1	3.75 BSC			
e	0.50 BSC			
k	0.40	-	-	
L	0.45	0.55	0.65	
L1	0.05	0.15	0.25	
L2	0.05	0.10	0.15	
N	20			3
Ne	5			
Nd	5			
P	0.24	0.42	0.60	
θ	0	-	12°	

EXPOSED PAD VARIATIONS						
PKG. CODES	D2			E2		
	MIN.	NOM.	MAX.	MIN.	NOM.	MAX.
G2044Y+1	1.95	2.1	2.25	1.95	2.1	2.25



TITLE:
PACKAGE OUTLINE, 20L, 4x4x0.85MM
SIDE WETTABLE QFN PKG.

APPROVAL	DOCUMENT CONTROL NO. 21-0576	REV. B	2/4
----------	---------------------------------	-----------	-----

STEP CUT VERSION

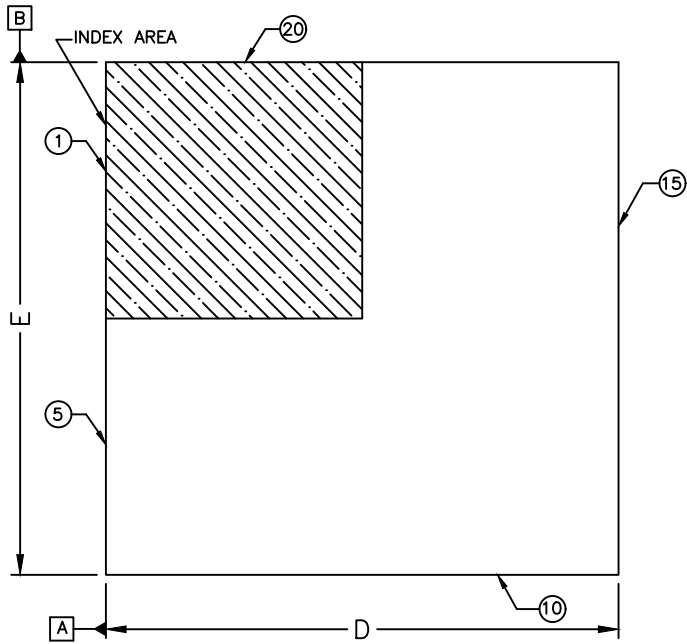

TOP VIEW

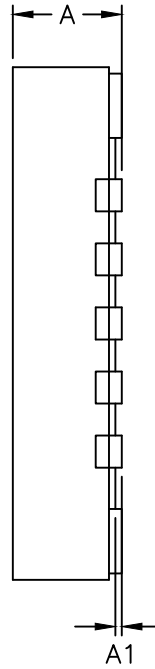

SIDE VIEW

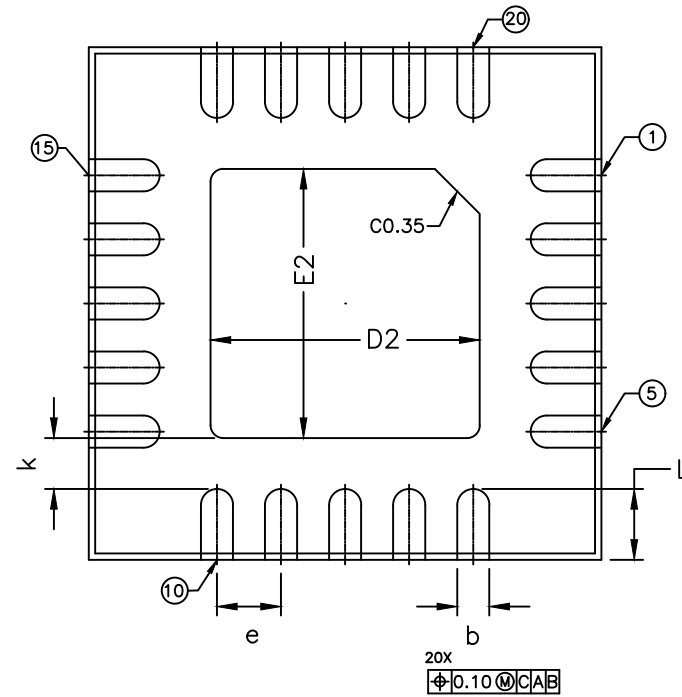

BOTTOM VIEW

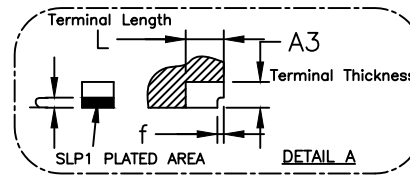
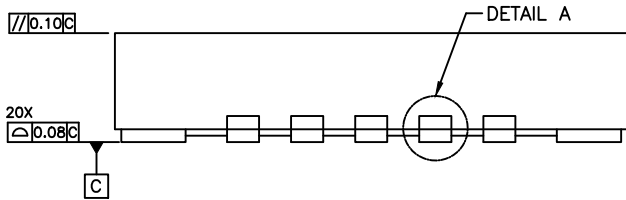

TITLE:
PACKAGE OUTLINE, 20L, 4x4x0.85MM
SIDE WETTABLE QFN PKG.

APPROVAL

DOCUMENT CONTROL NO.
21-0576

REV. B 3/4

-DRAWING NOT TO SCALE-

STEP CUT VERSION

NOTES

1. N IS THE NUMBER OF TERMINALS.
2. ALL DIMENSIONS ARE IN MILLIMETERS.
3. MEETS JEDEC MO220.
4. MATERIAL MUST COMPLY WITH BANNED AND RESTRICTED SUBSTANCES SPEC # 10-0131.
5. COPLANARITY APPLIES TO THE EXPOSED PAD AS WELL AS THE TERMINALS. COPLANARITY SHALL NOT EXCEED 0.08MM
6. WARPAGE SHALL NOT EXCEED 0.10MM
7. ALL DIMENSIONS APPLY TO PbFREE (+) PKG. CODE ONLY.

SYMBOL	COMMON DIMENSIONS		
	MIN.	NOM.	MAX.
A	0.80	0.85	0.90
A1	0.00	0.01	0.05
A2	-	0.65	-
A3	0.203 REF.		
b	0.20	0.25	0.30
f	0.01	0.05	0.09
D	3.90	4.00	4.10
h	0.05	0.10	0.175
E	3.90	4.00	4.10
L	0.45	0.55	0.65
e	0.50 BSC		
k	-	0.40	-
N	20		

EXPOSED PAD VARIATIONS						
PKG. CODES	D2			E2		
	MIN.	NOM.	MAX.	MIN.	NOM.	MAX.
G2044Y+1	2.00	2.10	2.20	2.00	2.10	2.20



TITLE:
PACKAGE OUTLINE, 20L, 4x4x0.85MM
SIDE WETTABLE QFN PKG.

APPROVAL	DOCUMENT CONTROL NO. 21-0576	REV. B	4/4
----------	---------------------------------	-----------	-----

-DRAWING NOT TO SCALE-