

TOP VIEW

SIDE VIEW

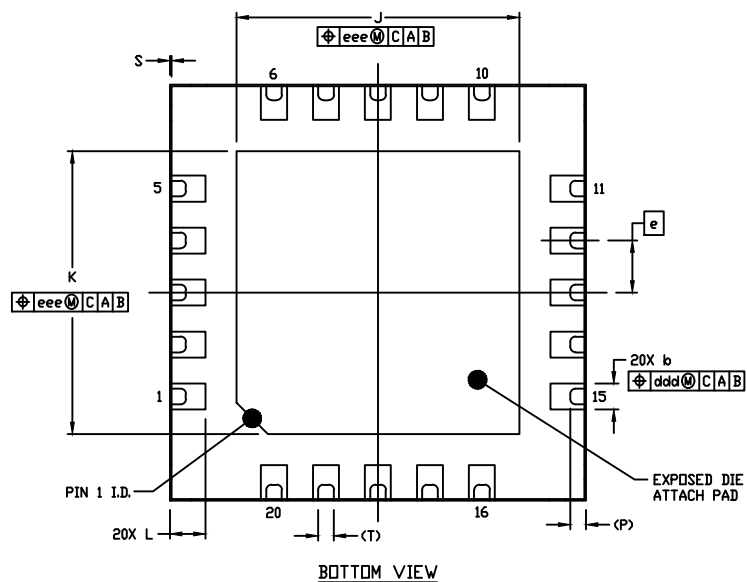

BOTTOM VIEW

	SYMBOL	MIN	NOM	MAX
TOTAL THICKNESS	A	1.3	1.35	1.4
STAND OFF	A1	0	0.035	0.05
MOLD THICKNESS	A2	---	1.147	---
L/F THICKNESS	A3	0.203 REF		
LEAD WIDTH	b	0.2	0.25	0.3
BODY SIZE	X	D		
	Y	E		
LEAD PITCH	e	0.5 BSC		
EP SIZE	X	J	2.62	2.72
	Y	K	2.62	2.72
LEAD LENGTH	L	0.29	0.34	0.39
MOLD FLATNESS	bbb	0.1		
COPLANARITY	ccc	0.08		
LEAD OFFSET	ddd	0.1		
EXPOSED PAD OFFSET	eee	0.1		
HALF-CUT DEPTH	R	0.075	---	---
HALF-CUT WIDTH	S	0	0.015	0.03
WETTABLE DIMPLE WIDTH	T	0.15 REF		
WETTABLE DIMPLE LENGTH	P	0.15 REF		
WETTABLE DIMPLE DEPTH	Q	0.1 REF		

NOTES:

1. ALL DIMENSION AND TOLERANCE CONFORM TO ASME Y14.5M-1994.
2. ALL DIMENSION ARE IN MILLIMETERS UNLESS OTHERWISE SPECIFIED.
3. N IS THE TOTAL NUMBER OF TERMINALS.
4. BILATERAL COPLANARITY ZONE APPLIES TO THE EXPOSED PAD AS WELL AS THE TERMINALS.
5. ALL DIMENSION APPLY TO BOTH LEADED (-) AND PbFREE (+) PKG. CODES.
6. DRAWING CONFORMS TO JEDEC MO-220.
7. MARKING SHOWN IS FOR PACKAGE ORIENTATION REFERENCE ONLY.
8. CONTROLLING DIMENSION: mm.
9. PKG. CODE: Q2044Y+3
10. MATERIAL MUST BE COMPLIANT WITH MAXIM SPECIFICATION 10-0131 FOR SUBSTANCE CONTENT, MUST BE Eu ROHS COMPLIANT WITHOUT EXEMPTION AND PB-FREE.
11. TOTAL THICKNESS "A" NOT TO INCLUDE SAW BURRS.



TITLE:
PACKAGE OUTLINE, 20L, □C, SW, QFN,
4x4x1.35mm

APPROVAL QI LUD	DOCUMENT CONTROL NO. 21-100562	REV. A	1/1
--------------------	-----------------------------------	-----------	-----

-DRAWING NOT TO SCALE-