

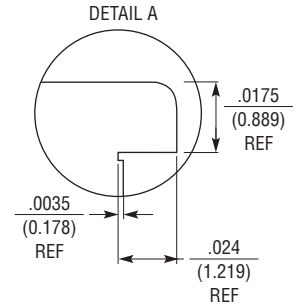

ADI Power by Linear™

S8E Package
Exposed Pad Variation AA
8-Lead Plastic SOIC (Narrow .150 Inch) Exposed Pad
(Reference LTC DWG # 05-08-1796 Rev A)

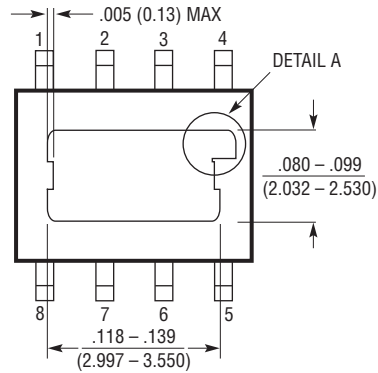
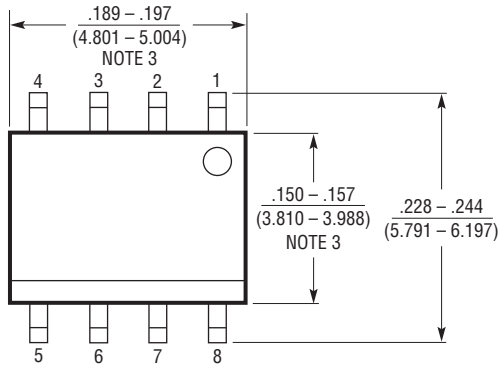

BOTTOM VIEW-EXPOSED PAD

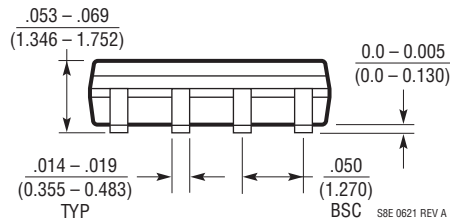
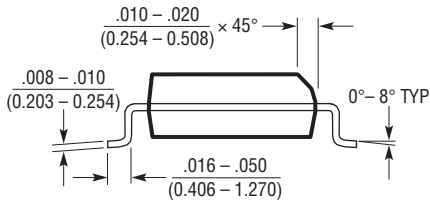

NOTE:
1. DIMENSIONS IN INCHES (MILLIMETERS)

2. DRAWING NOT TO SCALE

3. THESE DIMENSIONS DO NOT INCLUDE MOLD FLASH OR PROTRUSIONS.

MOLD FLASH OR PROTRUSIONS SHALL NOT EXCEED .010" (0.254mm) EXCEPT DETAIL A.

DETAIL A PAD OPENING MOLD FLASH OR PROTRUSIONS SHALL NOT EXCEED .0004" (0.01mm).

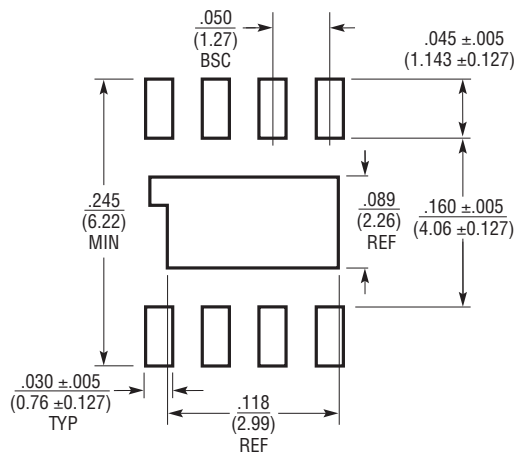

RECOMMENDED SOLDER PAD LAYOUT