

REV	DESCRIPTION	DATE	APPROVED
00	INITIAL COMPOSITE DRAWING	8/7/07	MD

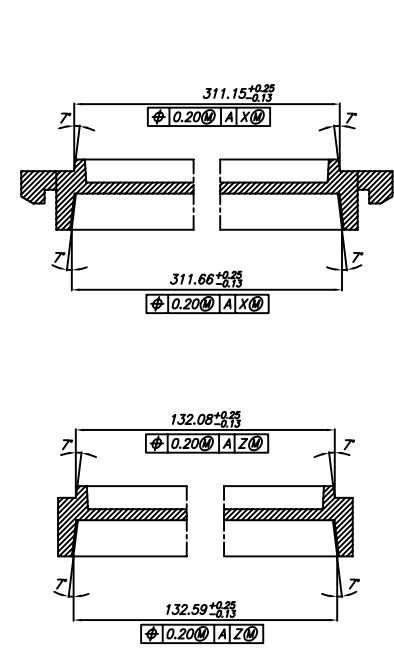

TRAY STACKING DETAIL
(SCALE:4/1)

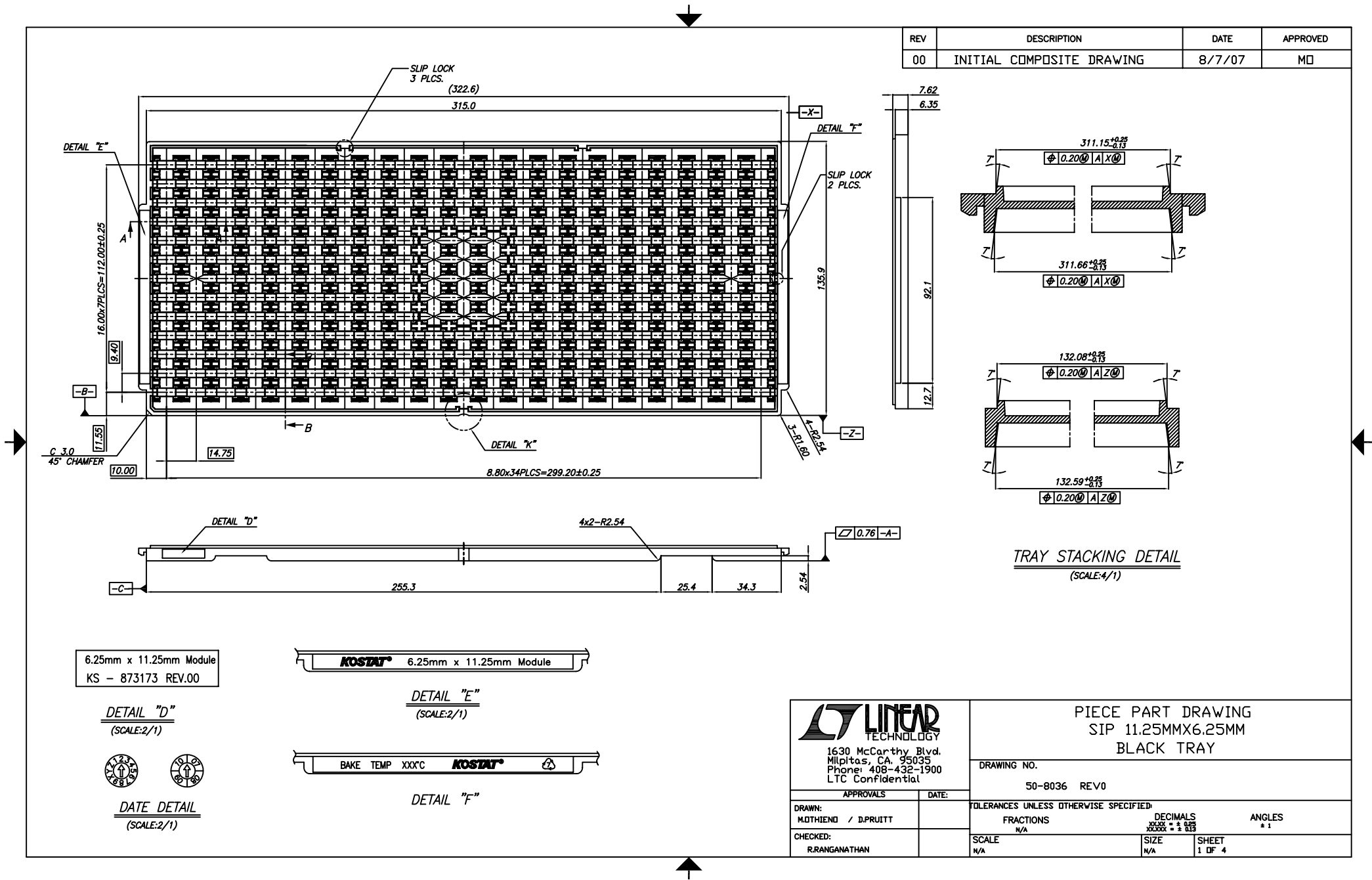
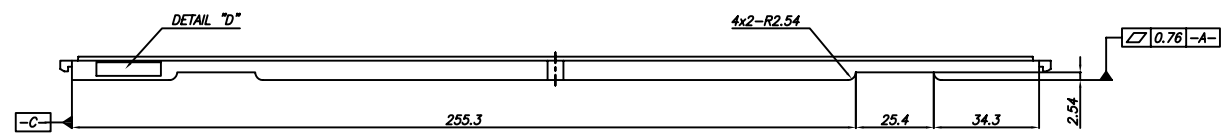

6.25mm x 11.25mm Module
KS - 873173 REV.00

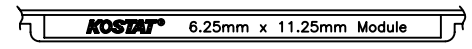

DETAIL "D"
(SCALE:2/1)

DETAIL "E"
(SCALE:2/1)



DATE DETAIL
(SCALE:2/1)



DETAIL "F"

LINEAR TECHNOLOGY
1630 McCarthy Blvd.
Milpitas, CA. 95035
Phone: 408-432-1900
LTC Confidential

PIECE PART DRAWING
SIP 11.25MMX6.25MM
BLACK TRAY

DRAWING NO.
50-8036 REV0

APPROVALS
DRAWN: M.DHIEND / D.PRUITT

TOLERANCES UNLESS OTHERWISE SPECIFIED:
FRACTIONS N/A
DECIMALS
XX.XX = ± 0.25
XXX.XXX = ± 0.13
ANGLES ± 1

CHECKED:
R.RANGANATHAN

SCALE N/A
SIZE N/A
SHEET 1 DF 4

REV	DESCRIPTION	DATE	APPROVED
00	INITIAL COMPOSITE DRAWING	8/7/07	MD

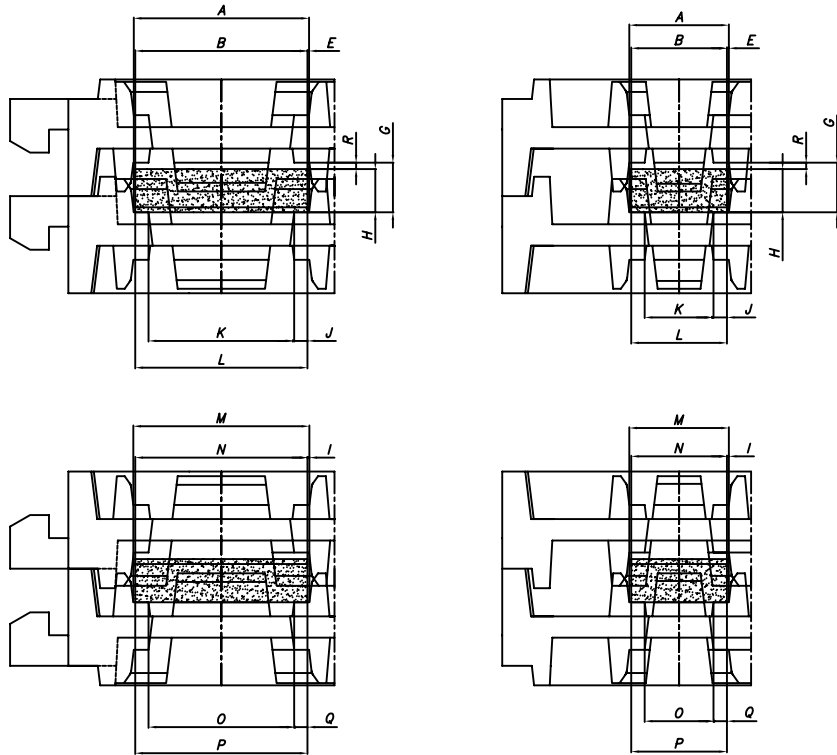

SIMULATION CRITERIA	
1. $A > B$	PACKAGE NESTING
2. $E > 0$	PACKAGE LATERAL PLAY
3. $G > H$	PACKAGE VERTICAL PLAY
4. $I > 0$	PACKAGE LATERAL PLAY AT FLIPPED
5. $K < L$	PACKAGE SEATING
6. $J > 0$	PACKAGE SEATING PLAY
7. $M > N$	PACKAGE NESTING AT FLIPPED
8. $O < P$	PACKAGE SEATING AT FLIPPED
9. $Q > 0$	PACKAGE SEATING PLAY AT FLIPPED

No.	Section "AA" Condition	Nominal	Max. TRAY Min. PKG		Results
			Wc 1	Wc 2	
1	Tray A	11.450	11.530	11.370	Pass
	Pkg. B	11.250	11.150	11.350	
2	Gap. $E(A-B)/2$	0.100	0.190	0.010	Pass
	Tray G	3.250	3.380	3.120	
3	Pkg. H	2.820	2.720	2.920	Pass
	Gap. $R(G-H)$	0.430	0.660	0.200	
5	Gap. $I(M-N)/2$	0.125	0.215	0.035	Pass
	Tray K	9.510	9.640	9.380	
6	Pkg. L	11.250	11.150	11.350	Pass
	Gap. $J(L-K)/2$	0.870	0.755	0.985	
8	Tray M	11.500	11.580	11.420	Pass
	Pkg. N	11.250	11.150	11.350	
9	Tray O	9.510	9.640	9.380	Pass
	Pkg. P	11.250	11.150	0.985	
10	Gap. $Q(P-O)/2$	0.870	0.755	0.985	Pass

No.	Section "BB" Condition	Nominal	Max. TRAY Min. PKG		Results
			Wc 1	Wc 2	
1	Tray A	6.500	6.580	6.420	Pass
	Pkg. B	6.250	6.150	6.350	
2	Gap. $E(A-B)/2$	0.125	0.215	0.035	Pass
	Tray G	3.250	3.380	3.120	
3	Pkg. H	2.820	2.720	2.920	Pass
	Gap. $R(G-H)$	0.430	0.660	0.200	
5	Gap. $I(M-N)/2$	0.125	0.215	0.035	Pass
	Tray K	4.500	4.630	4.370	
6	Pkg. L	6.250	6.150	6.350	Pass
	Gap. $J(L-K)/2$	0.875	0.760	0.990	
8	Tray M	6.500	6.580	6.420	Pass
	Pkg. N	6.250	6.150	6.350	
9	Tray O	4.500	4.630	4.370	Pass
	Pkg. P	6.250	6.150	6.350	
10	Gap. $Q(P-O)/2$	0.875	0.760	0.990	Pass

LINEAR TECHNOLOGY
 1630 McCarthy Blvd.
 Milpitas, CA. 95035
 Phone: 408-432-1900
 LTC Confidential

PIECE PART DRAWING
 SIP 11.25MMX6.25MM
 BLACK TRAY

DRAWING NO.
 50-8036 REV0

APPROVALS	DATE:	TOLERANCES UNLESS OTHERWISE SPECIFIED:		
DRAWN: M.MATHIEND / D.PRUITT		FRACTIONS	DECIMALS ± 0.005 ± 0.013	ANGLES # 1
CHECKED: R.RANGANATHAN		SCALE N/A	SIZE N/A	SHEET 2 OF 4

REV	DESCRIPTION	DATE	APPROVED
00	INITIAL COMPOSITE DRAWING	8/7/07	MD

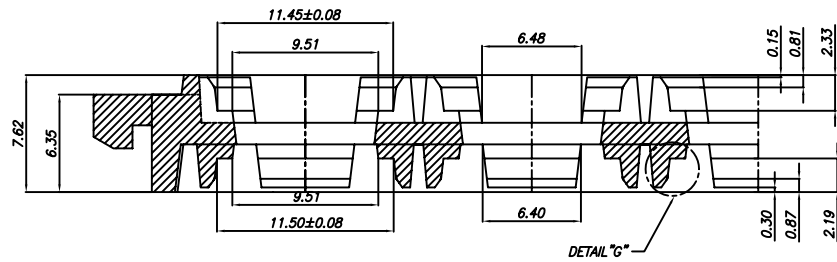

SECTION "A-A"
(SCALE:5/1)

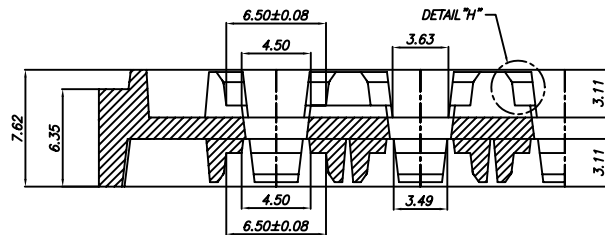

SECTION "B-B"
(SCALE:5/1)

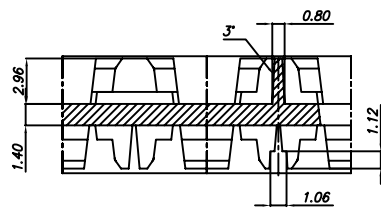

VACUUM CELL
(SCALE:5/1)

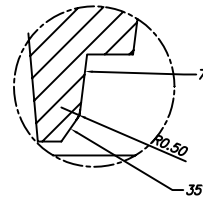

DETAIL "G"
(SCALE:12/1)

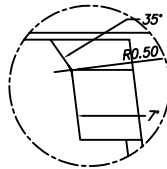

DETAIL "H"
(SCALE:12/1)

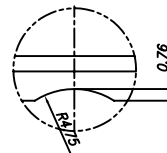

DETAIL "K"
(SCALE:4/1)

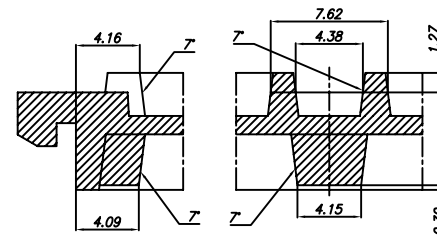

SLIP LOCK 3 PLCS.
(SCALE:5/1)

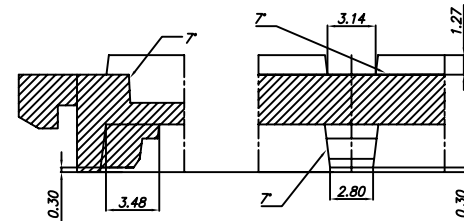

SLIP LOCK 2 PLCS.
(SCALE:5/1)

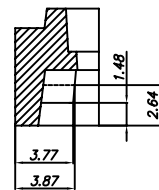

STRAP SUPPORT
(SCALE:5/1)

 1630 McCarthy Blvd. Milpitas, CA. 95035 Phone: 408-432-1900 LTC Confidential		PIECE PART DRAWING SIP 11.25MMX6.25MM BLACK TRAY		
		DRAWING NO. 50-8036 REV0		
APPROVALS	DATE:	TOLERANCES UNLESS OTHERWISE SPECIFIED:		
DRAWN: MOTHIEND / DPRUITT		FRACTIONS N/A	DECIMALS XX.XX = ± 0.02 XX.XXX = ± 0.013	ANGLES * 1
CHECKED: R.RANGANATHAN		SCALE N/A	SIZE N/A	SHEET 3 OF 4

REV	DESCRIPTION	DATE	APPROVED
00	INITIAL COMPOSITE DRAWING	8/7/07	MD

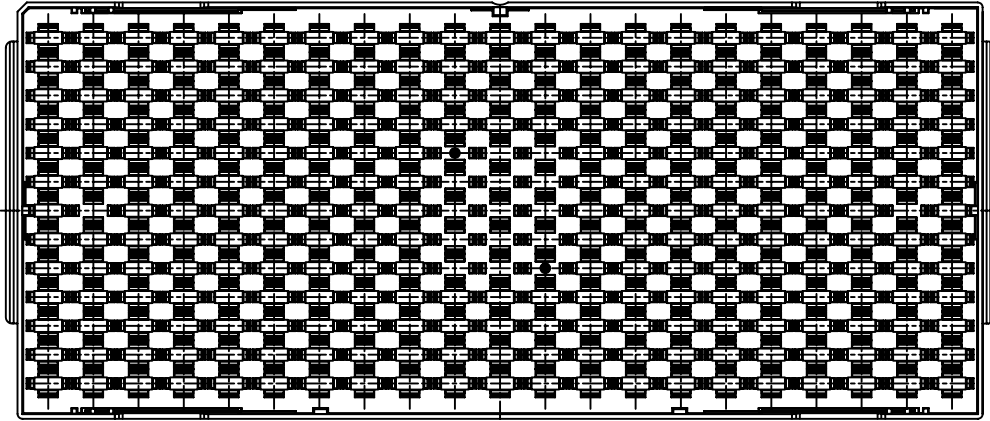

BOTTOM VIEW
(SCALE:1/1)

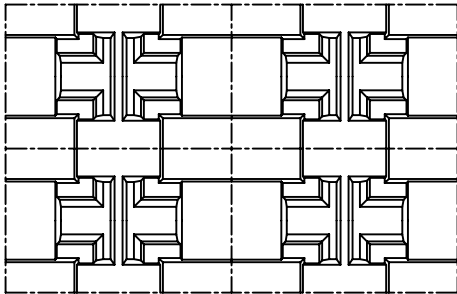

TOP VIEW
(SCALE:5/1)

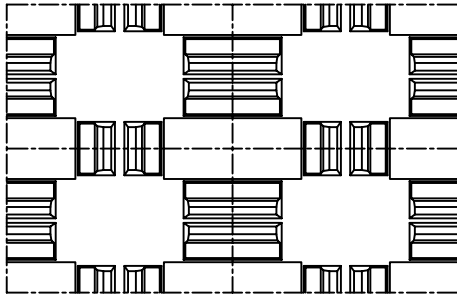

BOTTOM VIEW
(SCALE:5/1)

LINEAR
TECHNOLOGY
1630 McCarthy Blvd.
Milpitas, CA. 95035
Phone: 408-432-1900
LTC Confidential

PIECE PART DRAWING
SIP 11.25MMX6.25MM
BLACK TRAY

DRAWING NO.
50-8036 REV0

APPROVALS: _____ DATE: _____
DRAWN: M.OTHIEND / D.PRUITT
CHECKED: R.RANGANATHAN

TOLERANCES UNLESS OTHERWISE SPECIFIED:
FRACTIONS N/A DECIMALS .005 = ± .005 .010 = ± .010 .020 = ± .010 ANGLES ± 1°
SCALE N/A SIZE N/A SHEET 4 OF 4