

REV	DESCRIPTION	DATE	APPROVED
00	INITIAL COMPOSITE DRAWING	09/09/09	MD

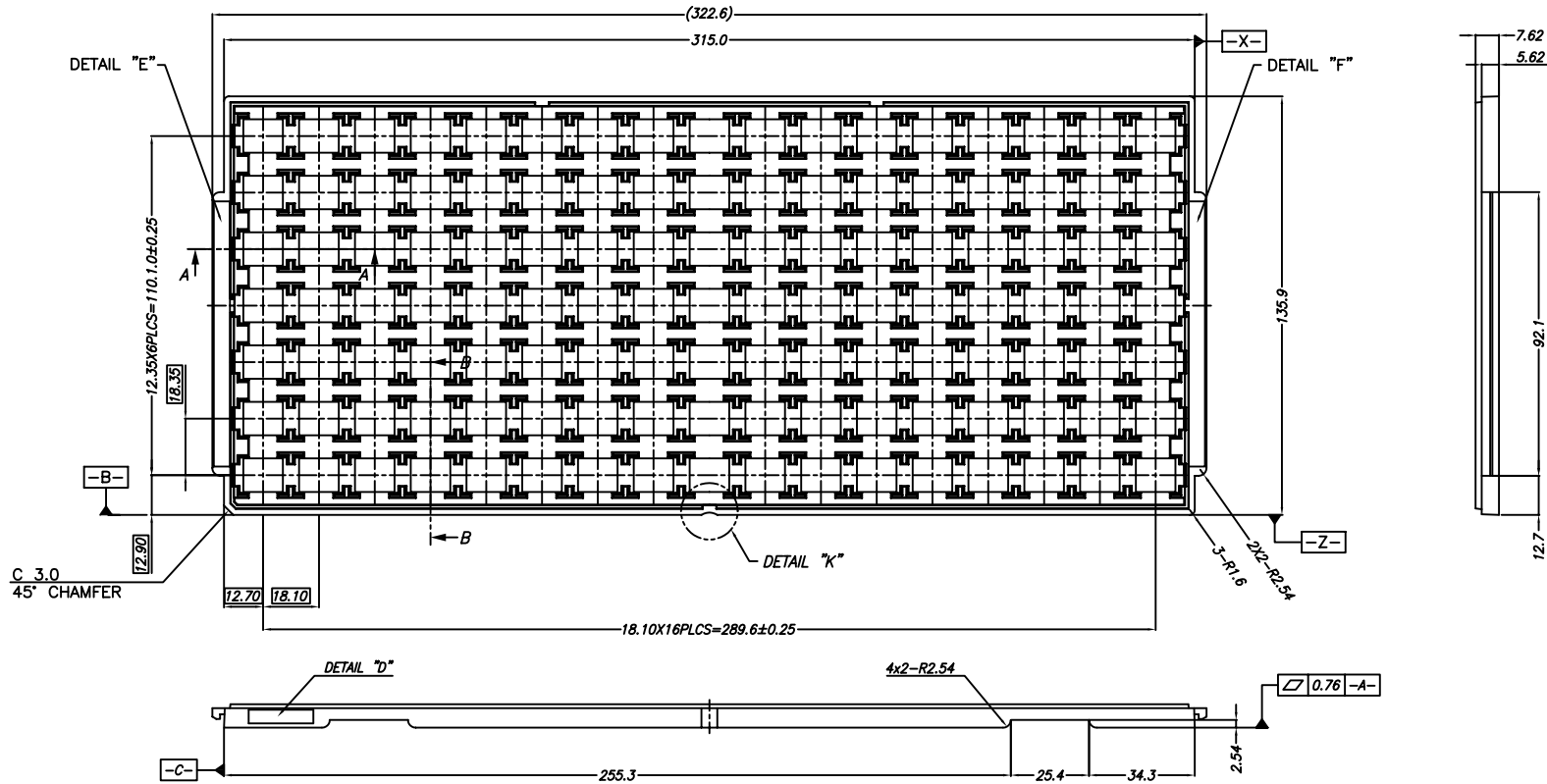

LGA 11.25mmx15.00mm
 KS-870317 REV.00

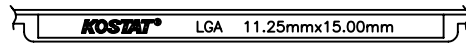

DETAIL "D"
 (SCALE:2/1)

DETAIL "E"
 (SCALE:2/1)



DATE DETAIL
 (SCALE:2/1)

DETAIL "F"

LINEAR
 TECHNOLOGY
 1630 McCarthy Blvd.
 Milpitas, CA, 95035
 Phone: 408-432-1900
 LTC Confidential

PIECE PART DRAWING
 LGA 11.25mm X 15.00mm
 BLACK TRAY

DRAWING NO.
 50-8062 REV0

APPROVALS: DRAWN: M.MOITHIEND / D.PRUITT
 CHECKED: R.RANGANATHAN

TOLERANCES UNLESS OTHERWISE SPECIFIED:		
FRACTIONS N/A	DECIMALS XXX ± 0.03 XXXX ± 0.03	ANGLES ± 1
SCALE N/A	SIZE N/A	SHEET 1 OF 4

REV	DESCRIPTION	DATE	APPROVED
00	INITIAL COMPOSITE DRAWING	09/09/09	MD

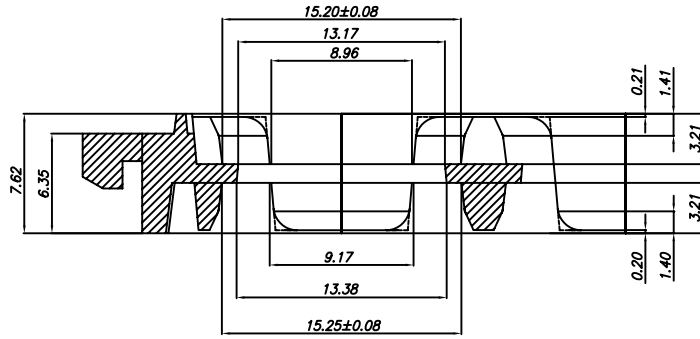

SECTION "A-A"
(SCALE:5/1)

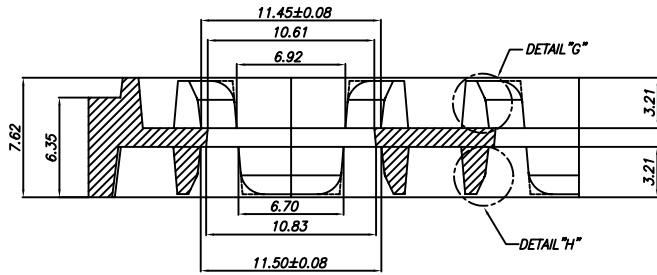

SECTION "B-B"
(SCALE:5/1)

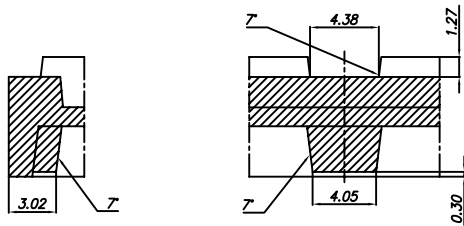

SLIP LOCK DETAIL
(SCALE:5/1)

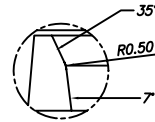

DETAIL "G"
(SCALE:8/1)

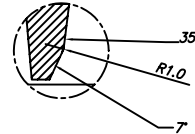

DETAIL "H"
(SCALE:12/1)

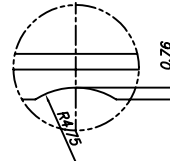

DETAIL "K"
(SCALE:5/1)

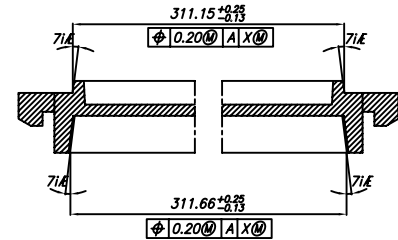

TRAY STACKING DETAIL
(SCALE:4/1)

LINEAR TECHNOLOGY
1630 McCarthy Blvd.
Milpitas, CA. 95035
Phone: 408-432-1900
LTC Confidential

PIECE PART DRAWING
LGA 11.25mm X 15.00mm
BLACK TRAY

DRAWING NO.
50-8062 REV0

APPROVALS	DATE:	TOLERANCES UNLESS OTHERWISE SPECIFIED:		
DRAWN: MOTHIEND / DPRUITT		FRACTIONS N/A	DECIMALS XXX ± 0.03 XXXX ± 0.03	ANGLES ± 1
CHECKED: R.RANGANATHAN		SCALE N/A	SIZE N/A	SHEET 2 OF 4

REV	DESCRIPTION	DATE	APPROVED
00	INITIAL COMPOSITE DRAWING	09/09/09	MD

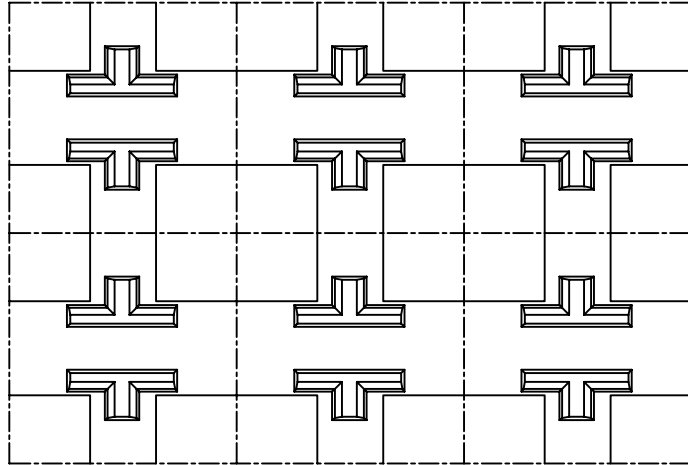

TOP VIEW
(SCALE:4/1)

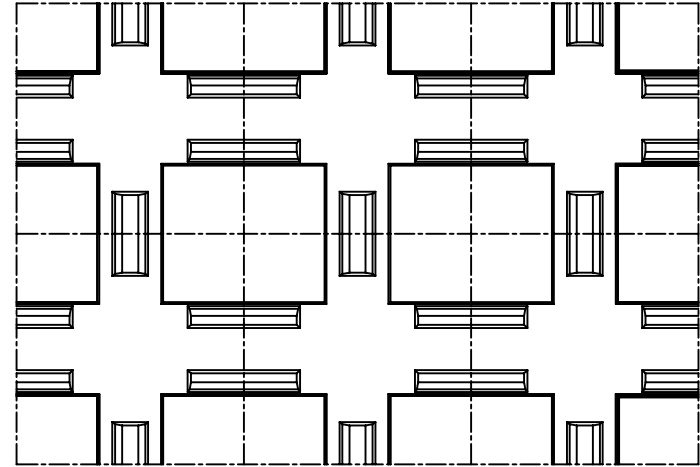

BOTTOM VIEW
(SCALE:4/1)

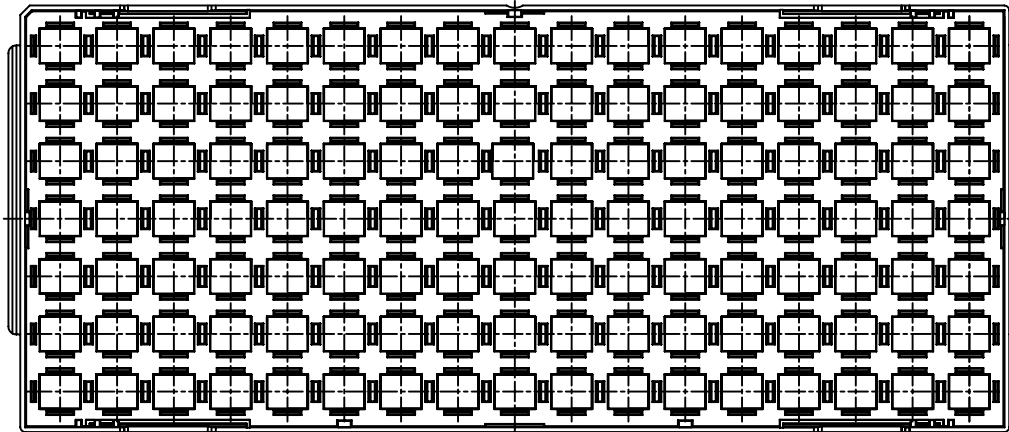

BOTTOM VIEW
(SCALE:1/1)

 1630 McCarthy Blvd. Milpitas, CA. 95035 Phone: 408-432-1900 LTC Confidential	PIECE PART DRAWING LGA 11.25mm X 15.00mm BLACK TRAY		
	DRAWING NO. 50-8062 REV0		
APPROVALS	DATE:	TOLERANCES UNLESS OTHERWISE SPECIFIED:	
DRAWN: M.OTHEND / D.PRUITT		FRACTIONS N/A	DECIMALS XXXX ± 0.02 XXXX ± 0.03
CHECKED: R.RANGANATHAN		SCALE N/A	ANGLES ± 1
		SIZE N/A	SHEET 3 OF 4

REV	DESCRIPTION	DATE	APPROVED
00	INITIAL COMPOSITE DRAWING	09/09/09	MD

SIMULATION CRITERIA						
1.	$A > B$	PACKAGE LATERAL PLAY				
2.	$C > D$	BALL LATERAL PLAY				
3.	$E < F$	BALL TOUCH THE SHELVES				
4.	$G > H$	PACKAGE VERTICAL PLAY				
5.	$J > I$	OVERMOLD TOUCH THE SHELF				
6.	$K > L$	BALL TOUCH THE FLOOR				
7.	$M > N$	PACKAGE LATERAL PLAY (FLIPPED)				
No.	Condition Section "A-A"		Nominal	Max. TRAY Min. PKG	Min. TRAY Max. PKG	Results
1	Tray	A	15.200	15.280	15.120	Pass
	Pkg.	B	15.000	14.900	15.100	
2	Tray	C	13.150	13.280	13.020	Pass
	Pkg.	D	12.000	11.950	12.050	
3	Gap.	$E(A-B/2)$	0.100	0.190	0.010	Pass
	Gap.	$F(C-D/2)$	0.575	0.665	0.485	
4	Tray	G	5.150	5.280	5.020	Pass
	Pkg.	H	4.350	4.220	4.480	
5	Gap.	$I(M-N/2)$	0.125	0.215	0.035	Pass
	Gap.	$J(O-P/2)$	-	-	-	
6	Tray	K	1.200	1.330	1.070	Pass
	Pkg.	L	0.450	0.400	0.500	
7	Tray	M	15.250	15.330	15.170	Pass
	Pkg.	N	15.000	14.900	15.100	
No.	Condition Section "B-B"		Nominal	Max. TRAY Min. PKG	Min. TRAY Max. PKG	Results
1	Tray	A	11.450	11.530	11.370	Pass
	Pkg.	B	11.250	11.150	11.350	
2	Tray	C	10.600	10.730	10.470	Pass
	Pkg.	D	9.640	9.590	9.690	
3	Gap.	$E(A-B/2)$	0.100	0.190	0.010	Pass
	Gap.	$F(C-D/2)$	0.480	0.570	0.390	
4	Tray	G	5.150	5.280	5.020	Pass
	Pkg.	H	4.350	4.220	4.480	
5	Gap.	$I(M-N/2)$	0.125	0.215	0.035	Pass
	Gap.	$J(O-P/2)$	-	-	-	
6	Tray	K	1.200	1.330	1.070	Pass
	Pkg.	L	0.450	0.400	0.500	
7	Tray	M	11.500	11.580	11.420	Pass
	Pkg.	N	11.250	11.150	11.350	

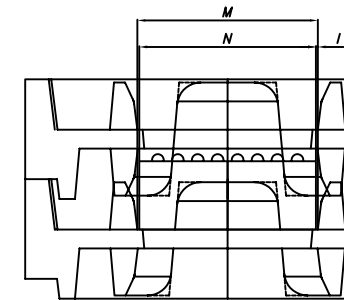
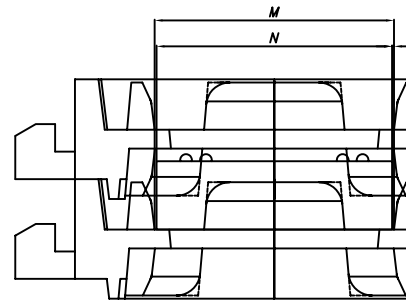
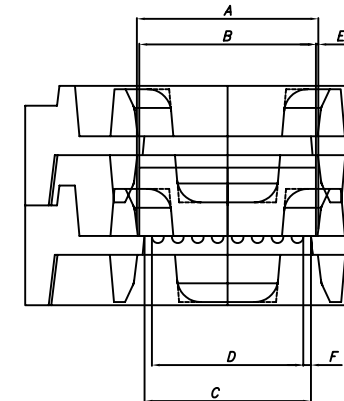
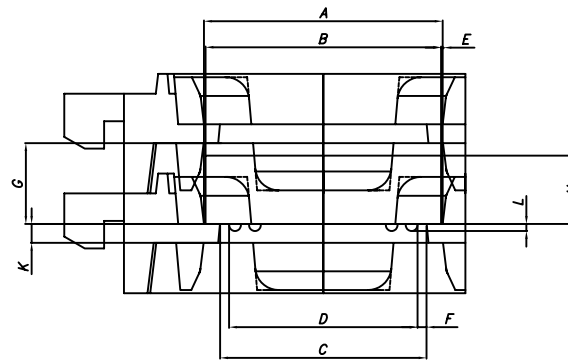

LINEAR TECHNOLOGY
 1630 McCarthy Blvd.
 Milpitas, CA. 95035
 Phone: 408-432-1900
 LTC Confidential

APPROVALS: _____ DATE: _____
 DRAWN: M.OTHEND / D.PRUITT
 CHECKED: R.RANGANATHAN

PIECE PART DRAWING
 LGA 11.25mm X 15.00mm
 BLACK TRAY

DRAWING NO. 50-8062 REV0

TOLERANCES UNLESS OTHERWISE SPECIFIED:
 FRACTIONS N/A DECIMALS $\frac{XXX}{1000} = \pm 0.025$ ANGLES ± 1
 SCALE N/A SIZE N/A SHEET 4 OF 4